

OPERATION AND MAINTENANCE MANUAL, W11 TRIPLEX PUMPS

Rev	ECN No.	Date	Reviewed By	Approved By	Status
C	5041126	30-SEP-2016	Rothe, Michael	Kowalski, Christopher	RELEASED

Summary:

This is a manual for FMC W11 triplex piston pumps. These pumps include a pinion drive for internal gear reduction; they have a stroke length of 2.75 inches, and maximum continuous duty power ratings ranging from 20 horsepower (15 kilowatts) for the W1118 to 30 horsepower (22 kilowatts) for the W1122. The maximum intermittent duty rating is 24 horsepower (18 kilowatts) for the W1118 to 36 horsepower (27 kilowatts) for the W1122. Refer to part number [5266226](#) for printing information.

**BUCKHORN
PUMPS, INC.**

Table of Contents

1.0	Important Safety Instructions	6
2.0	W11 Pump Features	7
3.0	Storage Instructions	8
3.1	Short Term Storage	8
3.2	Short Term Storage for Severe Environments	8
3.3	Long Term Storage	8
3.4	Returning a Stored Pump to Operation	9
3.5	Precautions during Freezing Weather	9
4.0	Installation Guidelines	11
4.1	General Location	11
4.2	Mounting Pump to Foundation and Power Source	11
4.3	Suction Piping Recommendations	12
4.4	Discharge Piping Recommendations	13
4.5	Multiple Pump Systems	14
5.0	How to Start a Pump	15
6.0	Lubrication of the Power End	17
6.1	Recommended Lubricants	17
6.2	Oil Changes	17
7.0	Inspection and Preventative Maintenance Chart	19
8.0	Estimated Life of Wearing Components	20
9.0	Component Parts List	21
10.0	Service Procedures	25
10.1	Replacing Cup Pistons	25
10.2	Removing the Fluid Cylinder	28
10.3	Replacing Valves	30
10.3.1	Valve Assembly and Knock Out Tool	31
10.3.2	Replacing W11 Disc Type Valves	32
10.3.3	Valve Removal and Installation Tools	33
10.3.4	Installation of Disc Valves	34
10.4	Servicing the Power End	35
10.4.1	Replacing Piston Rod Oil Seals	35
10.4.2	Rebuilding the Power End	36
11.0	Fastener Torque Requirements	42
12.0	Critical Clearances	43
13.0	Special Service Tools	44
14.0	Troubleshooting Your FMC Pump	45
15.0	Ordering Parts	48

16.0 Glossary of Commonly Used Terms 49
17.0 Reference Information 52
18.0 MAINTENANCE LOG 53



List of Figures

Figure 1: W11 Pump Assembly Features	7
Figure 2: Power End Components	21
Figure 3: Fluid End Components.....	23
Figure 4: Using the Installation and Knock Out Tool.....	31
Figure 5: Typical W11 Disc Valve Assembly	32
Figure 6: Illustration of the P534694 or P534695 Ball Valve Knock Out Tools.....	33



List of Tables

Table 1: Allowable Working Pressure for Steel Pipe (psi @ 100°F).....	13
Table 3: W11 Maintenance Schedule.....	19
Table 4: Power End Component List.....	22
Table 5: Fluid End Component List.....	24
Table 6: Torque Values for Critical Pump Fasteners.....	42
Table 7: Torque Values for Xylan-Coated Fasteners.....	42
Table 8: Clearance Chart.....	43
Table 10: Troubleshooting W11 Pumps.....	45



1.0 Important Safety Instructions



WARNING

Many accidents occur every year through careless use of mechanical equipment. You can avoid hazards associated with high pressure equipment by always following the safety precautions listed below.

- **Shut down or disengage** the pump and all accessory equipment before attempting any type of service. Failure to do this could cause electrical shock or injury from moving pump parts or components under high pressure. Always adhere to "Lock Out" and "Tag Out" procedures. For mobile equipment, be sure engines and hydraulics cannot be accidentally started.
- **Bleed off all pressure** to the pump and piping before performing any maintenance on the pump. Failure to do so may spray water or chemicals at high pressure or high temperature onto service personnel.
- **Never operate the pump without a pressure relief valve**, rupture disc, or other type of properly sized over pressure safety device installed.
- **Always use a pressure gage** when operating the pump. The pressure must never exceed the maximum pressure rating of the pump or damage may occur. This damage can cause leakage or structural damage resulting in injury to personnel.
- **Ensure that no valves are placed between the pump and pressure relief valve**. If the pump is started with a closed or restricted valve in line before the pressure relief valve, the pump may exceed the rated or design pressure limits and rupture causing injury to personnel.
- **Use shields or covers around pumps** when pumping hot water, chemicals, or other hazardous liquids. This precaution can prevent the exposure of service personnel to these fluids should leakage occur.
- **Always use guards** on all belt drives, couplings, and shafts. Guards can prevent personnel from becoming entangled and injured or killed by rotating and reciprocating parts.
- **Use extreme caution with solvents** used to clean or degrease equipment. Most solvents are highly flammable and toxic. Observe all safety instructions on packaging.
- **Follow normal environmental guidelines** when fluids, lubricants, or solvents are disposed of or spilled.
- **Never modify the pump** to perform beyond its rated specifications without proper authorization in writing from FMC.

2.0 W11 Pump Features

Exceptional design, workmanship, materials, and over 100 years of pump building experience are features you'll find built into every FMC pump. The W Series pumps include configurations with fluid ends designed with disc valves or ball valves for viscous fluids with stringy matter.

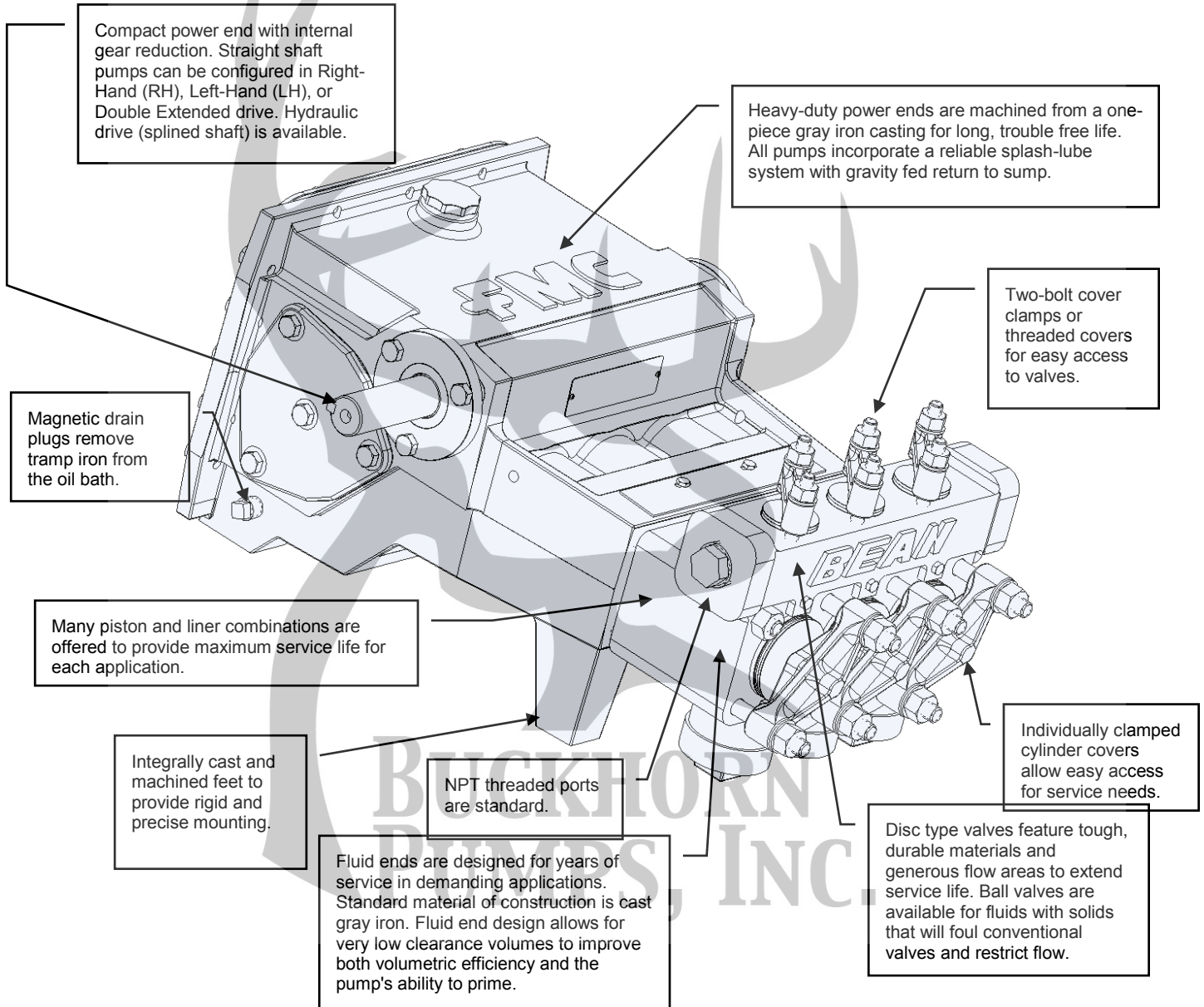

Figure 1: W11 Pump Assembly Features

3.0 Storage Instructions

Proper storage of your FMC pump will ensure that it is ready for service when needed. Follow the guidelines below that fit the requirements of your application.

FMC pumps come from the factory without crankcase oil and are prepared for storage periods of up to six months in proper environmental conditions. Indoor storage in a dry, temperature-controlled location is always recommended. If pumps are to be stored short term (less than six months) in a severe environment, they should be prepared using the procedures outlined in the "Short Term Storage for Severe Environments" Section 3.2 below. If the pump is to be stored or inactive for periods in excess of six months, it is necessary to prepare the pump as outlined in the "Long Term Storage" Section 3.3. Remember that any fluid that poses an environmental hazard or is toxic must be handled and disposed of properly.

3.1 Short Term Storage

If the pump is stored in an indoor, temperature-controlled environment for less than six (6) months, no special steps are required to prepare it for storage. As a general rule for pumps in corrosive fluid applications, the fluid end should be drained, flushed with water or another non-corrosive cleanser, and compressed air should be used to blow dry whenever idle.

3.2 Short Term Storage for Severe Environments

If the pump has been in service, drain any fluid from pump fluid end, flush the fluid end with water to clean out any of the remaining pumpage, and blow dry with compressed air. Pour 1/4 to 1/2 cup of internal rust inhibitor oil described in Table 2 (see Recommended Lubricant Chart, Section 6.0), into the suction and discharge ports of fluid end, then install pipe plugs in openings. Drain the power end crankcase oil and remove the oil fill cap or plug. Pour 1/2 to 1 cup of internal rust inhibitor oil described in Table 2 into the oil fill hole, and then install the filler cap.

Coat all exposed, unpainted metal surfaces (for example, Driveshaft) with preservative oil. Replace the oil fill cap, and then cover the entire pump with a weather resistant covering such as a canvas or plastic tarp.

3.3 Long Term Storage

Long-term storage is defined as any period when the pump is in storage or is idle for longer than six months. If the pump has been in service, drain any fluid from the pump fluid end, flush the fluid end with water to clean out any of the remaining pumpage, and blow dry using compressed air. Pour 1/4 to 1/2 cup of internal rust inhibitor oil described in Table 2 into the suction and discharge ports of fluid end, and then install pipe plugs in openings. Remove the piston cup seals as described in Section 10.1 "Replacing Cup

Type Pistons" of this manual, seal them in a bag, and store them in a separate location with a controlled environment where they are protected from UV exposure.

Drain the oil from the pump power end. Remove the rear cover to expose the drive components. Spray all internal parts with a rust preservative that is soluble in lubricating oil while rotating the driveshaft several turns by hand to ensure complete coverage. Replace the rear cover and add ½ to 1 cup of internal rust inhibitor described in Table 2.

Spray a rust preventative on all exterior machined surfaces paying attention to any unpainted areas like the crankshaft extension. Remove the oil fill cap and store with the piston cup seals. Cap the breather opening with a plug or other suitable means in order to keep the preservative atmosphere sealed inside the power end.

Never store the pump on the floor or ground. Always place it on a shelf or pallet that is several inches above ground level. Cover the entire pump with a canvas or plastic tarp. Every two months inspect the unit. Rotate the crankshaft by hand at least 4 turns during each inspection. Drain and replace the rust inhibitor after every six months of storage.

3.4 Returning a Stored Pump to Operation

Before operating a pump that has been prepared for storage, drain the preservative and lubricating oil mixture from the power end (crankcase). Remove the rear cover and apply recommended crankcase lubricant (Refer to Table 2 in Section 6.0) to the pinion bearings. Reinstall the rear cover, drain plug, breather/filler cap, piston cup seals, and any other components that were removed for storage. Once these steps have been completed, follow the normal pump start up procedures outlined in this manual. NOTE: FMC can factory prepare units for long term storage for a nominal fee if specified at the time of order.

3.5 Precautions during Freezing Weather

Freezing weather can cause problems for equipment when pumping water-based fluids that expand in volume when changing from a liquid to a frozen solid state. When water is left in a pump fluid end and exposed to freezing temperatures, the expansion of the water as it freezes can rupture the fluid cylinder of the pump and cause equipment damage. Injury may result when starting equipment that has been damaged.

Whenever the pump is stored or idle in conditions that are near or below freezing, any water based fluids should be removed from the pump. The best way to do this is to run the pump for a few seconds with the suction and discharge lines disconnected or open to atmosphere. This will clear the majority of the fluid from the pumping chamber as well as the suction and discharge manifolds. After the run, blow compressed air through the fluid end to remove all traces of fluid. If possible, remove plugs from the bottom of the fluid cylinder and lift up the suction valve seats to ensure that all fluid is drained from the pumping chamber between the suction and discharge valves.

As an alternative to the previous procedure, a compatible antifreeze solution can be circulated through the fluid end. RV antifreeze, propylene glycol is recommended for

this purpose. Remember that any fluid that poses an environmental hazard or is toxic must be handled and disposed of properly.



4.0 Installation Guidelines

A proper installation is essential to optimal performance, long service life, and reduced maintenance requirements. Take time to thoroughly plan all aspects of your installation.

4.1 General Location

It is important to position the pump on as flat and level of a surface as possible to assist the splash oil lubrication system. Park mobile equipment, such as sewer cleaner trucks or drilling machines, on as level of a surface as possible. Whenever possible, the pump should be mounted in a clean, dry location with sufficient lighting and adequate space for easy inspection and maintenance. Locate the pump as close to the suction source as possible to allow for the shortest and most direct routing of the inlet piping.

4.2 Mounting Pump to Foundation and Power Source

The W11 model pumps described in this document must be mounted in a horizontal position only. Secure the pump to the mounting surface using the four (4) holes provided in the pump base. Check motor or engine rotation direction to ensure that the top of the pump pinion shaft rotates away from the pump fluid end when in operation.

For units that are v-belt driven, check the alignment of the sheaves after the unit is installed on its permanent mount. Tighten belts to the proper tension as recommended by the belt manufacturer. Verify that the sheaves are in line and parallel to each other with a straight edge.



Never operate the pump without the belt or shaft guard securely installed.

CAUTION

For spline-driven units, ensure the shafts are centered and parallel when the driver is mounted to the pump. Follow the coupling manufacturer instructions for installation procedures and tolerances.

4.3 Suction Piping Recommendations

Poor suction piping practices are a very common source of pump problems. To ensure proper operation it is very important to follow good design practice in the installation of the suction system before the pump is operated. A small amount of additional planning and investment in the piping system usually provides for better pump performance and longer periods between service requirements. It is difficult to diagnose many pump problems without the aid of a suction pressure gage. For this reason, FMC recommends that a gage is always installed in the suction line directly before it enters the pump.

The suction line from the fluid source to the pump should be as short and direct as possible. Use rigid piping, non-collapsible hose or a combination of both as circumstances require in your installation. The suction pipe size should be at least equal to or one size larger than the pump inlet. Long piping runs, low suction heads, or indirect pipe routing may require even greater over-sizing of the suction line for proper operation of the pump. A suction pulsation dampener is recommended to reduce the effects of acceleration head to help when suction conditions are not optimal. In some cases, it may be necessary to install a booster pump in the suction line to obtain sufficient pressure for the pump to operate satisfactorily.

The suction line must be configured so there are no high spots in the line where air pockets can collect. These pockets may make the pump difficult to prime and cause rough, erratic operation. A drain valve or plug should be installed at the low point of the suction line to allow for draining before freezing conditions or for maintenance.

FMC recommends that all piping is supported independently of the pump. By supporting the piping this way, vibrations are reduced and stress on the pump is kept to a minimum. The use of elbows, nipples, unions, or other fittings should be minimized. Make sure that all joints and connections are airtight. Air leaks reduce the capacity of the pump and can result in cavitation, rough operation, and/or loss of prime. To help isolate mechanical and hydraulic vibrations, FMC recommends the use of flexible pipe couplings or hose connections between the pump and any rigid piping.

Always ensure that calculated system Net Positive Suction Head available, NPSHa, exceeds pump Net Positive Suction Head required, NPSHr, by at least 5 feet (1.5 meters) of water for proper operation of the pump. NPSH requirements for each pump model are provided on the product data sheets available through FMC or your authorized FMC reseller. FMC does not recommend using the pump in static lift conditions without prior factory approval.

4.4 Discharge Piping Recommendations

Table 1: Allowable Working Pressure for Steel Pipe (psi @ 100°F)

Pipe Size (inches)	Pipe Schedule				
	40	80	120	160	XX
1/2	2300	4100		7300	12300
3/4	2000	3500		8500	10000
1	2100	3500		5700	9500
1 1/4	1800	3000		4400	7900
1 1/2	1700	2800		4500	7200
2	1500	2500		4600	6300
2 1/2	1900	2800		4200	6900
3	1600	2600		4100	6100
3 1/2	1500	2400			5600
4	1400	2300	3350	4000	5300
5	1300	2090	2950	3850	4780
6	1210	2070	2850	3760	4660
8	1100	1870	2840	3700	3560

14.5 psi = 1 bar

1. Route the discharge piping in the shortest, most direct route possible. Use the same pipe size as the outlet of the pump. In installations where the discharge piping is in excess of 50 feet (15 meters) it is suggested to use the next larger size pipe to minimize friction losses downstream.



CAUTION

Always use pipe or hose that is designed for your particular pressure requirements. Inadequate pressure ratings can allow hose or pipe to fail, resulting in equipment damage and possibly personal injury. Normal hose pressure ratings are clearly marked on the outer surface of the hose. Working pressure ratings for steel pipe can be obtained from the manufacturer or from the chart shown in Table 1.

2. **Always use a pressure gage in the pump discharge line.** A properly functioning gage mounted at the pump (and before any valves) is required to accurately determine the operating pressure of a pump and to conduct troubleshooting.
3. Ensure that all piping is supported independently of the pump to reduce vibrations and strain on the pump. Pulsation dampeners on the discharge are recommended to reduce pressure pulsation and resulting vibration. The use of elbows, nipples, unions, or other fittings should be kept to an absolute minimum. Avoid short radius 90° elbows; use two long radius 45° elbows instead. To help isolate mechanical and hydraulic vibrations, FMC recommends the use of flexible pipe

couplings or hose connections between the pump and any rigid piping or the use of pulsation dampeners.

4. A properly adjusted pressure relief valve or rupture disc must be installed directly downstream of the pump to prevent damage or injuries resulting from overpressure or deadhead conditions. The relief valve discharge line must be as large as the pipe outlet of the relief valve. Never install valves in the relief valve discharge line or between the pump and relief valve. FMC recommends that the discharge be returned to the tank or drain, not back into the pump suction line.
5. It is recommended that a start-up bypass line and valve is installed to allow flow to bypass the relief valve. This allows the pump to start in an unloaded condition (no discharge pressure).

4.5 Multiple Pump Systems

Special consideration must be taken to avoid vibration, pulsation, or uneven flow distribution problems when operating multiple reciprocating pumps using common suction and discharge piping headers. It is recommended that the user contact FMC or experienced industry consultants for assistance with the design of the system and pump installation in these situations.



BUCKHORN
PUMPS, INC.

5.0 How to Start a Pump



CAUTION

Always take special precautions when starting a pump for the first time or after any extended shutdown. Never assume that someone else has properly prepared the pump and system for operation. Always check each component of the system prior to every start-up.

The checklist that follows is intended to be a general guide for starting a pump in a typical installation. Every installation is different, and each will have different requirements to ensure safe and successful operation. **It is the responsibility of the operator to determine the correct start-up procedure for each installation.**

1. Ensure that the drain plug(s) on the bottom of the pump crankcase have been installed and are tight. Ensure that the oil level sight glass, if equipped, has been properly installed.
2. Check the oil level to ensure that the pump is properly filled with non-detergent motor oil or a synthetic oil as described in Table 2 and that the oil has not been contaminated with water or other contaminants.



WARNING

FMC pumps are shipped with no oil in the power frame and must be filled to the proper level with the proper grade of oil prior to start-up.

W11 pumps require 6 1/4 quarts (5.9 liters) of oil



NOTE

Consult Table 2 in Section 6.0 for selecting the correct type of non-detergent motor oil or synthetic oil for your service.

3. If accessible, check the piston rods to ensure that they are free from abrasive particles or debris.
4. Ensure that the pressure relief valve and all accessory equipment have been installed and properly adjusted. Verify that all joints are pressure tight.

5. Open the suction line valve to allow fluid to enter pump. Prime the fluid cylinder if necessary on the initial start up or after the system piping has been drained. The valve covers may have to be cracked open to assist with priming.



Do not loosen the valve covers with volatile or hazardous fluids.

CAUTION

6. Check to ensure that power is locked out and tagged out. Turn the pump over by hand if possible to ensure free, unobstructed operation.
7. Apply 10 to 20 drops of glycerin or mineral oil to the pistons, cylinders, and piston rods to lubricate the packing and seals.
8. Make sure that all guards are in place and secure. Verify that all personnel are in safe positions and that system conditions are suitable for operation.
9. The pump is now ready to start. NOTICE: Whenever possible, use a bypass in the discharge line to allow the pump to start in the unloaded condition (no discharge and pressure). Slowly close the bypass line to bring the pump into full load conditions. Shut down immediately if the flow becomes unsteady, pressure fluctuates, or if unusual sounds or vibrations are noted.
10. Take temperature readings of the power end and stuffing boxes. Do not exceed 170°F (77°C) for continuous duty applications on power end of W11 pumps.

**BUCKHORN
PUMPS, INC.**

6.0 Lubrication of the Power End

6.1 Recommended Lubricants

Few factors can influence the life of a pump more than the power end lubricant (oil). Careful selection of the right type of oil for each particular application will help ensure optimal performance and longevity from an FMC pump.

The intent of this section is to state the general lubrication requirements for FMC pumps. Several products are listed by manufacturer name in the table below in order to aid the customer in locating suitable lubricants. The following listing is not exclusive, and it is not an endorsement of any particular product or manufacturer. Consult FMC for lubrication recommendations for applications that fall outside of the conditions listed in Table 2 below.



NOTE

Lubricant temperatures should not exceed 170° F (77° C) for continuous duty or 180° F (82° C) for intermittent duty applications on W11 pumps. Crankcase temperatures that exceed these limits will cause the mineral based lubricant to prematurely "break-down." The result will be poor lubrication and failure of power end components.

6.2 Oil Changes

- Oil changes must be carried out after first 100 hours of operation, and subsequently every 4000 hours or 6 months, whichever comes first. These intervals may be modified depending on actual operating conditions.
- Oil should be changed when hot to prevent build up of sludge deposits.
- It is advisable to check oil level daily. If more than 10% of the total capacity has to be added, check for oil leaks.
- Do not mix oils of different types, even if produced by the same manufacturer.
- Never mix mineral and synthetic oils.
- To avoid the risk of scalding or burns, pay attention to oil and power end temperature during an oil change.
- Follow environmental guidelines when changing and disposing of lubricants.

Table 2: W11 Recommended Lubricants

Type of Service	Ambient Temp	Motor Oil Lubricant				Synthetic Lubricant *		
		SAE Grade	ISO Viscosity (cSt@40 C)	SSU Viscosity	Manufacturer Brand Name	SAE Grade	ISO Viscosity (cSt@40 C)	Manufacturer Brand Name
General Service	0 F to 100 F (-18 C to 38 C)	30	100	550	Texaco® Meropa 100	5W-40	90.0@40	Shell® Rotella T Synthetic SAE 5W-40
					Shell® Omala 100		15.0@100	
						NA	99.1@40	Mobil® SCH 627
							13.9@100	
High Ambient Temperature Service	100 F to 130 F (38 C to 54 C)	50	220	1165	Texaco® Meropa 68	5W-40	90.0@40	Shell® Rotella T Synthetic SAE 5W-40
					Shell® Omala 220		15.0@100	
						NA	217@40	Mobil® SCH 630
							29.9@100	
Cold Ambient Temperature Service	0 F to -30 F (-18 C to -34 C)	20	68	350	Texaco® Meropa 68	5W-40	90.0@40	Shell® Rotella T Synthetic SAE 5W-40
					Shell® Omala 68		15.0@100	
						10W-30	12.0@100	BP® Vanellus E 8 ULTRA 5W-30
						NA	69.9@40	Mobil® SCH 626
							10.9@100	
Frequent Start-Stop Operation		40	150	775	Texaco Meropa® 150			
SPECIALTY ITEMS								
Internal Rust Inhibitor				Cortec® VCI 329				
External Rust Preventative				Texaco® Metal Protective Oil L				

*Synthetic lubricants are suggested for high or low temperature service.

Cortec® is a registered trademark of Cortec Corporation, St. Paul, MN



7.0 Inspection and Preventative Maintenance Chart

Routine maintenance is an essential part of any successful pump installation. Properly maintained FMC pumps are designed to offer years of trouble-free service.

Regular maintenance and inspection will keep your pump operating at peak performance. FMC pumps have been carefully engineered to minimize maintenance requirements and simplify these tasks when they are required. Regular inspections allow operators to become familiar with normal pump operation so they can recognize the signals of potential problems and schedule maintenance. The maintenance chart in Table 3 shown below should be used as a guideline only. Many applications will require adjustment of the intervals shown in this chart for severe or unusual operating conditions.

Table 3: W11 Maintenance Schedule

Interval	Component	Service	Remarks
Break In Period	Crankcase Oil	Change	Drain and refill with new oil after first 100 hours of operation. Ensure that the magnetic drain plugs are cleaned to remove debris.
	Inlet Strainer	Inspect	Clean if Required. The amount of material in the strainer will determine the interval of cleaning.
Daily	Complete Pump	Inspect	General inspection of pump and system to check for proper operation of equipment.
	Piston cup sets	Inspect	Check the cylinder liner area of the pump for signs of leakage. Replace piston cups if leakage becomes excessive.
	Pump System	Flush	Required for shutdown when pumping fluids that may harden or corrode the pump if left inside once stopped.
	Crankcase Oil	Inspect	Ensure that the oil is at proper level and has not been contaminated by pumpage or condensation.
6 Months/ 4,000 hours	Crankcase Oil	Change	Drain and refill with new oil. Clean magnetic drain plugs.
	Cylinder Cover Bolts	Inspect	Check the cylinder cover bolts with a torque wrench to ensure they are within specification.
	Connecting Rod Bolts	Inspect	Check the connecting rod bolts with a torque wrench to ensure they are within specification. This should be done in conjunction with oil change.

8.0 Estimated Life of Wearing Components

The information given below is an estimation of the average wear life of specific components in clean liquid service. It is not a guarantee of life for any given application, but is intended to facilitate maintenance schedules and stocking of spare parts. The maintenance of the power end lubrication system will influence the life of the power end components. The speed of operation and percent of maximum allowable load will influence the life of both power end and fluid end parts. The temperature, abrasiveness, and lubricity of the liquid affect the life of fluid end expendables.

POWER END COMPONENT	ESTIMATED LIFE (Hours)
End Bearings (Roller or Ball)	20,000
Wrist Pin Bushings	10,000
Power End Cover Gasket	10,000
Connecting Rod Bearings	8,000
Oil Seal on Crankshaft or Pinion	5,000
Oil Seal on Piston (Pony) Rod	2,500
FLUID END COMPONENT	ESTIMATED LIFE (Hours)
Fluid Cylinder	16,000
Pistons	10,000
Valve Assembly	8,000
Ceramic Liners	3,000
Piston Cups	1,500



9.0 Component Parts List

A typical pump configuration is shown below for general reference purposes. This will aid in identifying components for service procedures outlined in the following sections. Each W11 pump may have a slightly different appearance.

To order service parts or see exact component configurations for your particular pump, refer to the cross-section parts drawing in the literature kit supplied with the pump. Contact your local FMC pump distributor or FMC if you do not have this information.

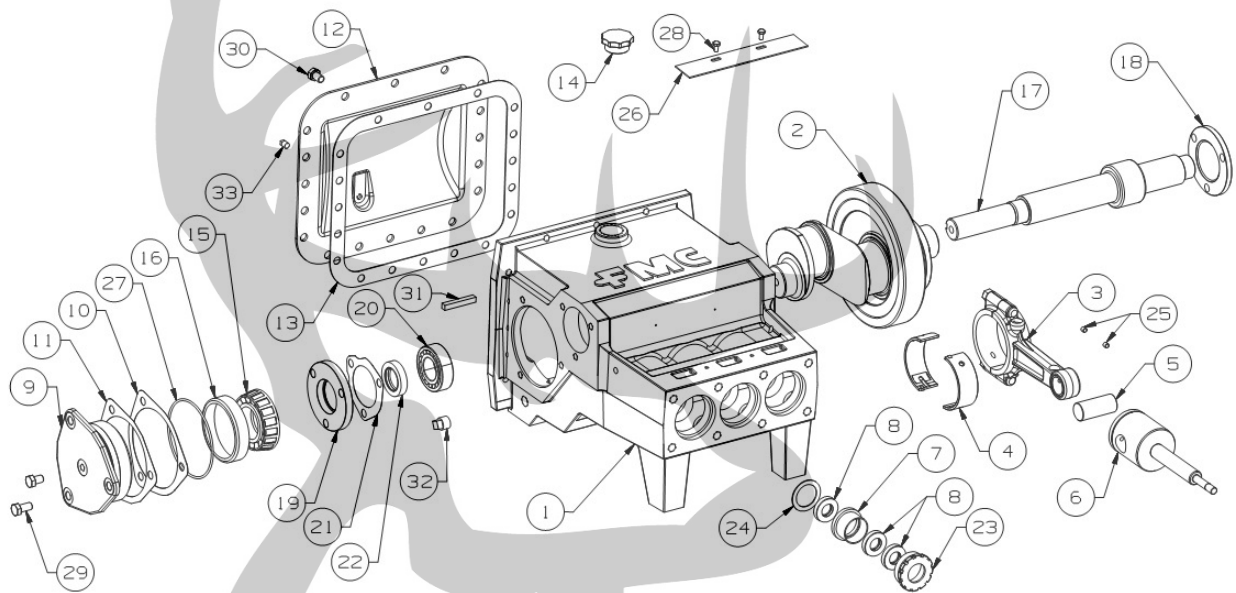
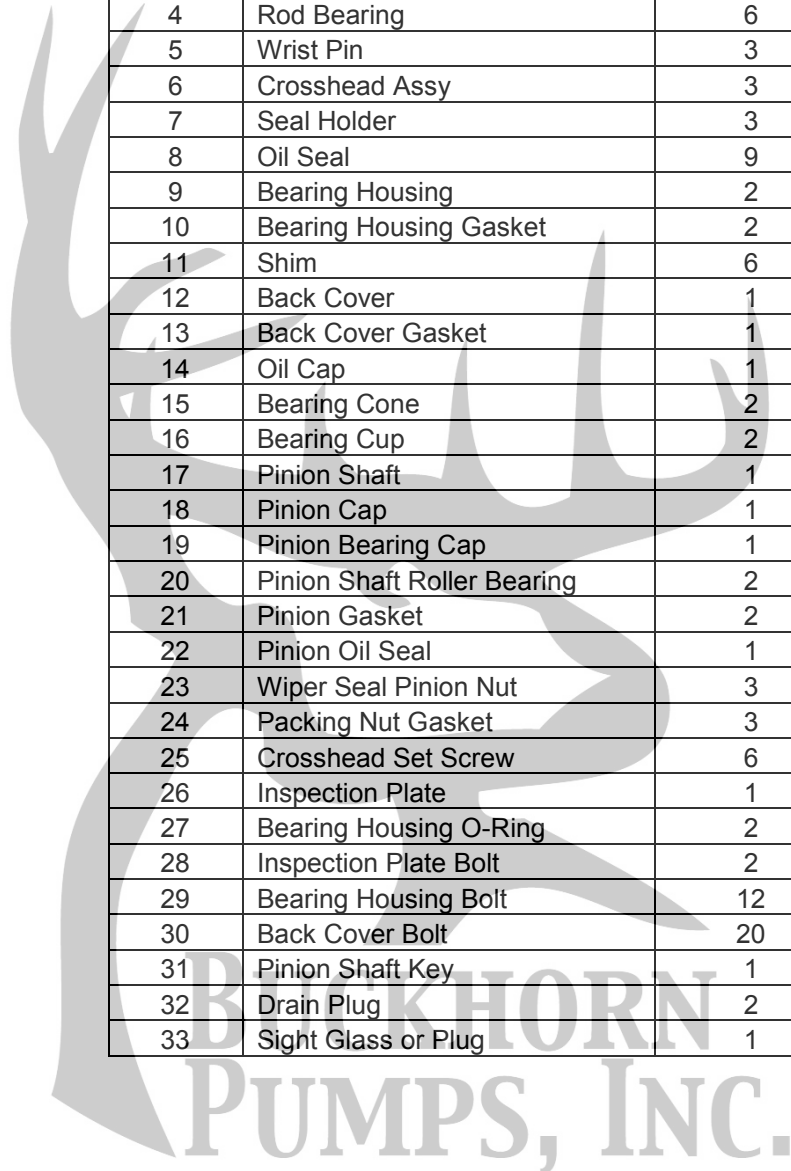

Figure 2: Power End Components

**BUCKHORN
PUMPS, INC.**

Table 4: Power End Component List

Item No.	Component Description	Quantity
1	Power Frame	1
2	Crankshaft	1
3	Connecting Rod	3
4	Rod Bearing	6
5	Wrist Pin	3
6	Crosshead Assy	3
7	Seal Holder	3
8	Oil Seal	9
9	Bearing Housing	2
10	Bearing Housing Gasket	2
11	Shim	6
12	Back Cover	1
13	Back Cover Gasket	1
14	Oil Cap	1
15	Bearing Cone	2
16	Bearing Cup	2
17	Pinion Shaft	1
18	Pinion Cap	1
19	Pinion Bearing Cap	1
20	Pinion Shaft Roller Bearing	2
21	Pinion Gasket	2
22	Pinion Oil Seal	1
23	Wiper Seal Pinion Nut	3
24	Packing Nut Gasket	3
25	Crosshead Set Screw	6
26	Inspection Plate	1
27	Bearing Housing O-Ring	2
28	Inspection Plate Bolt	2
29	Bearing Housing Bolt	12
30	Back Cover Bolt	20
31	Pinion Shaft Key	1
32	Drain Plug	2
33	Sight Glass or Plug	1



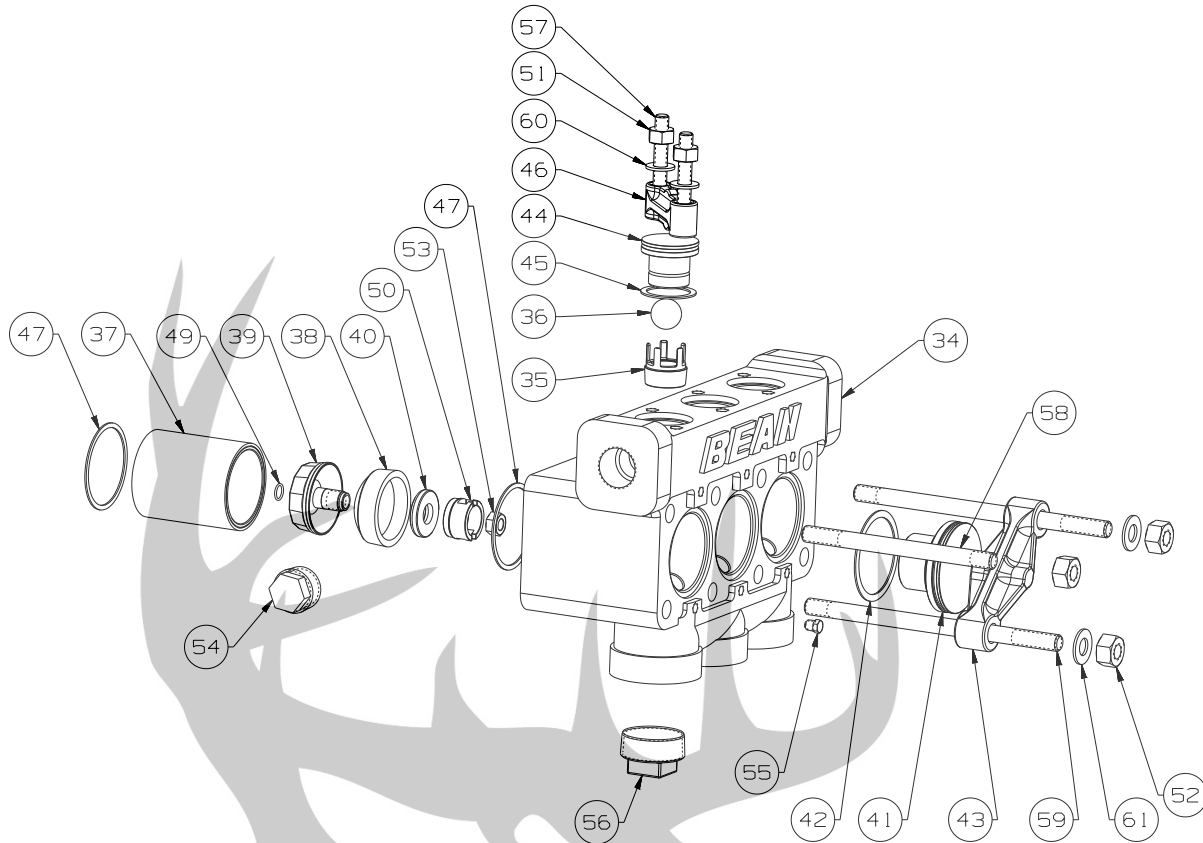

Figure 3: Fluid End Components

BUCKHORN
PUMPS, INC.

Table 5: Fluid End Component List

Item No.	Component Description	Quantity
34	Fluid Cylinder	1
35	Valve Seat	6
36	Ball Valve	6
37	Cylinder	3
38	Piston Cup	3
39	* Piston Holder	3
40	Piston Retainer	3
41	Cylinder Cover	3
42	Cylinder Cover Gasket	3
43	Cylinder Cover Clamp	3
44	Valve Cover	3
45	Valve Cover Gasket	3
46	Valve Cover Clamp	3
47	Cylinder Liner Gasket	6
48	Brass Petcock (Not Shown)	1
49	O-Ring	3
50	Piston Cup Nut	3
51	Valve Cover Clamp Nut	6
52	Fluid Cylinder Nut	8
53	Piston Assy Nut	3
54	Discharge Port Plug	1
55	Fluid Cylinder Drain Plug	6
56	Suction Port Plug	3
57	Valve Cover Stud	6
58	Fluid Cylinder Stud	2
59	Cylinder Cover Stud	6
60	Valve Cover Washer	6
61	Cylinder Cover Washer	6

* Some piston holders are grooved for the o-ring; others require a seal holder situated on the rod before the piston holder with the o-ring groove facing the piston holder

The illustrations above depict a typical pump with ball valves and clamp-on valve covers. Alternate construction threaded style valve covers may be used on some models.

The service procedures outlined in this manual are intended to describe the more commonly used type of pump. Other configurations and minor design differences may exist with different pumps. Some procedures may require slight adaptations as a result.

10.0 Service Procedures

FMC pumps are designed to simplify all required maintenance. The following sections illustrate step-by-step instructions for performing most common service procedures of a pump. Read each section before starting service work on the pump.

Refer to Figure 2 and Figure 3 for locations of components.



WARNING

Many accidents occur every year through careless use or service of mechanical equipment. You can avoid hazards associated with high-pressure equipment by always following the safety precautions listed in Section 1.0.

10.1 Replacing Cup Pistons

FMC W11 pumps are available with two different types of piston cups, pictured to the right. See Service Tips for installing Type B piston cups after Step 8 below.

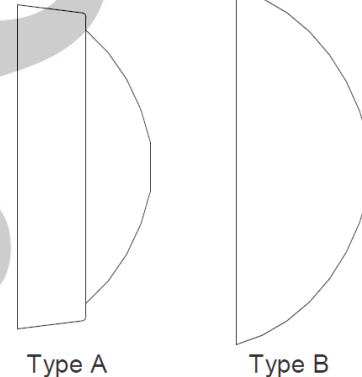

CAUTION

ENSURE THAT THE POWER IS LOCKED OUT AND TAGGED OUT BEFORE SERVICING ANY PART OF YOUR FMC PUMP



NOTE

To service the piston cups (38), approximately 2 feet of clearance is required between the front of the pump fluid cylinder (34) and any obstructions. If there is insufficient clearance, the pump must be removed and relocated to an area where adequate clearance exists.

1. FMC recommends that a sufficient quantity of clean water is pumped through the fluid end before starting any service procedures that involve fluid end components. This will remove most contaminants left in the fluid cylinder by normal pumpage and improve the ability to work with parts or see potential problems.
2. Bleed off all pressure inside pump fluid end before starting any service work. Shut the valve on the inlet piping, if provided, to prevent flow of liquid from the source into the pump during service.
3. To access the piston cups (38), the cylinder cover clamps (43) must be removed. Remove the six nuts (52) holding the cylinder cover clamps in place, and then remove the cylinder covers (41). If the cylinder covers are stuck to the fluid cylinder (34), insert a flathead screwdriver or small pry bar to pry off the cylinder covers (see picture to the right). Do not remove the two nuts on the short studs on opposite corners of the fluid cylinder, as they keep the cylinders (37) and fluid cylinder mounted on the pump during this operation.
4. Using a socket wrench with a long extension, remove the hex piston nut (53) from the piston/crosshead rod (6). This nut secures the piston assembly to the piston/crosshead rod.



NOTE

Pistons cups and assemblies can be removed with the fluid cylinder attached to the power frame by the two remaining nuts on the short studs to avoid replacing the cylinder gaskets.

5. Following the hex piston nut (53) removal, use the FMC piston tool (A5049) to pull the piston assembly from the cylinder (37). Insert the FMC piston tool inside the cylinder until flush with the face of the slotted piston retainer nut (50). Twist the tool to engage and lock the tabs of the tool inside the mating slots in the retainer nut.
6. Pull the piston assembly free using a



combination pulling and twisting motion.

7. Place the flats on the bottom of the piston holder (39) in a vice or clamp securely. Using the FMC piston tool (A5049), unscrew the piston assembly nut (53) and remove. The piston cup (38) and piston retainer nut (50) may now be removed.

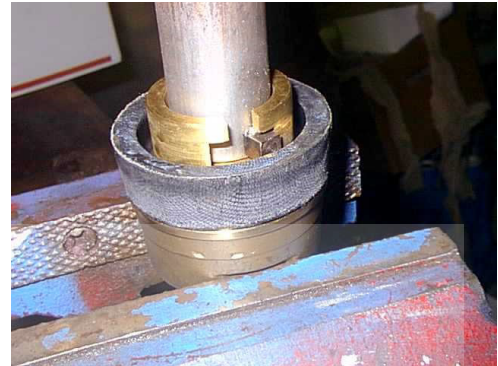

8. Inspect all parts for damage or unusual wear. Ensure that the interior surface of the cylinder (37) is smooth and free of cracks or grooves. New piston cups (38) will fail prematurely if installed in liners with damaged bores. FMC strongly recommends that all three piston cups be replaced, not just those that show signs of leakage, whenever this type of service is performed. This will maximize operational time between service intervals.

Service Tip – Due to the large uninstalled diameter, Type B piston cups on W11 pumps cannot be inserted through the fluid end without the risk of damaging the sealing surface of the cup. Any pump with Type A cups is not affected and you can follow this procedure without referencing the Service Tips below.

Service Tip – To perform service on W11 pumps equipped with Type B pistons, the fluid end must be removed and the liners must be taken to a bench or other work area for assembly. Follow the steps outlined in Section 10.2, "Removing the Fluid Cylinder" for information about this procedure.

Service Tip – Piston assemblies in W11 pumps must be installed in the piston liners using a press or vice as shown to the right. Be sure to protect both ends of the assembly with soft vice jaws, wood blocks, or a suitable non-marring material to ensure the components are not damaged during this process.



Service Tip – Press the piston assembly into the liner until the sealing lip has just entered the front of the liner. Use a small amount of glycerin on the ID of the liner to help lubricate the piston during installation. After the cylinder with piston has been installed in the pump power frame, drive the piston assembly fully to its stop using the FMC piston tool (A5049) and a rubber mallet.

9. Reverse steps 3 through 8 to rebuild the pump after worn or damaged components have been replaced. FMC recommends that all seals and gaskets that are disturbed during the service procedures be replaced. This includes the rod seal o-ring (49) that is located on the piston/crosshead rod shown directly behind the piston assembly. Some pump models have the o-ring in a groove in the piston holder instead of a separate seal holder. Lubricate the piston cups and piston rods during assembly.

10. Tighten all fasteners to the values specified in Fastener Torque Requirements, Section 11.0 of this manual.

10.2 Removing the Fluid Cylinder



The fluid cylinder (34) may be removed to inspect for internal damage, to be repaired, to replace the fluid cylinder, to replace damaged cylinders, cylinder o-rings, or to service piston rod seals.

NOTE

Refer to Figure 3 for illustration of parts.



FMC recommends that a sufficient quantity of clean water is pumped through the fluid end before starting any service procedures that involve fluid end components. This will remove most contaminants left in the fluid cylinder by normal pumpage and improve the ability to work with parts or see potential problems.

NOTE



ENSURE THAT THE POWER IS LOCKED OUT AND TAGGED OUT BEFORE SERVICING ANY PART OF YOUR FMC PUMP

CAUTION

1. Bleed off all pressure inside pump fluid end before starting any service work. Shut the valve on the inlet piping if provided to prevent flow of liquid from the source into the pump during service.
2. Remove the cylinder cover clamps (43) and cylinder covers (41) as described in the previous section. Remove the outside corner fluid cylinder nuts (52) if they are still in place.



3. Rock the fluid cylinder (34) to loosen from the cylinders (37), and then pull free of the fluid end studs (59). If the piston assemblies have already been removed, take care to ensure that the cylinders do not fall off of the front of the power end and become damaged.
4. To remove the piston assemblies, refer to steps 3 through 7 of the previous section.
5. Inspect all parts for signs of wear or damage. Replace parts as necessary in accordance with the previous section.
6. Always replace the cylinder gaskets (47) when the cylinders have been moved or replaced.
7. Reverse steps 2 through 6 to install the FMC W11 fluid cylinder (34).



8. Torque all fasteners as outlined in the Fastener Torque Requirements, Section 11.0 of this manual. Note that if the nuts (52) on the fluid cylinder studs (58, 59) are not properly torqued, likelihood of pump failure is greatly increased.

BUCKHORN PUMPS, INC.

10.3 Replacing Valves

1. A minimum of approximately 2 feet of clearance is required above, below, and in front of the pump fluid cylinder to allow valve service without removal of the fluid end. If sufficient clearance is not available, the fluid end must be removed as outlined in previous section and taken to a work shop for valve service. The following procedure is written under the assumption that sufficient clearances exist.
2. Remove the three suction plugs (56) from the bottom of the fluid cylinder (34).
3. Remove the six valve cover nuts (51) holding the valve cover clamps (46) and then remove the three valve covers (44) from the fluid cylinder.
4. The cylinder covers (41) on W11 pumps allow access for inlet valve removal. For these pumps, remove the cylinder covers as described in Section 10.1.
5. For ball valves, the balls are not attached to the valve seat. The ball can easily be removed from the valve assembly by lifting it out of the open cage portion of the valve seat. Then proceed using the Valve Seat Installation and Knock Out Tool, P534695 (see picture to the right) to remove the valve seats from the fluid cylinder.
6. Repeat step 5 for discharge valves.

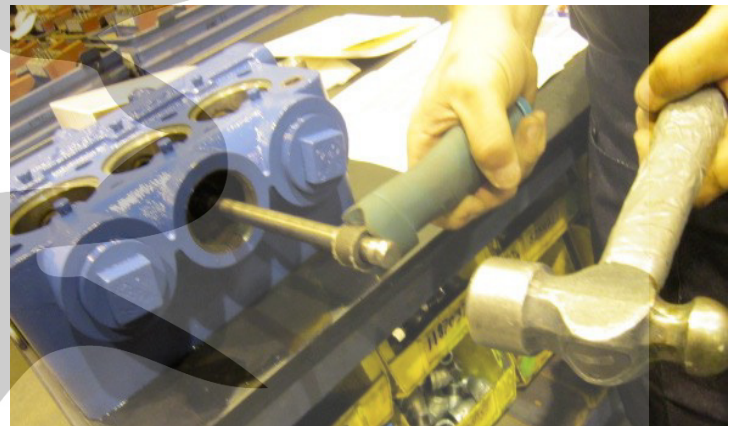

NOTE

This document describes the methods for removing and installing ball valves. For disc valves, the same procedure outlined for ball valves may be used. Disc valve W11s have one suction valve and one discharge valve assembly per pumping chamber that must be removed from the fluid cylinder as a valve-and-seat assembly.

7. After the valves have been replaced, FMC recommends that each cylinder cover gasket (42) for each cylinder cover (41) is replaced. Install the valve cover with the gasket in place, and install the valve cover clamps (43) over the valve cover studs (59). FMC recommends replacing the valve cover washers (60, if installed) and the valve cover hex nuts (52) if any of these parts are visually deformed.

8. Torque the valve cover hex nuts or hex plugs to the recommend values listed in the Fastener Torque Requirements, Section 11.0 below.

10.3.1 Valve Assembly and Knock Out Tool

The simplest of the tools is the removal and installation tool, part number [P534695](#) (small ball). For disc valves, [P534694](#) (large ball) tool should be used.

To remove a ball valve, this tool is inserted from the bottom of the fluid cylinder and is stopped by the bottom of the valve seat. The tool is struck firmly with a hammer and the valve is loosened. The suction valve can be removed first through the cylinder cover and the discharge valve through the valve cover.

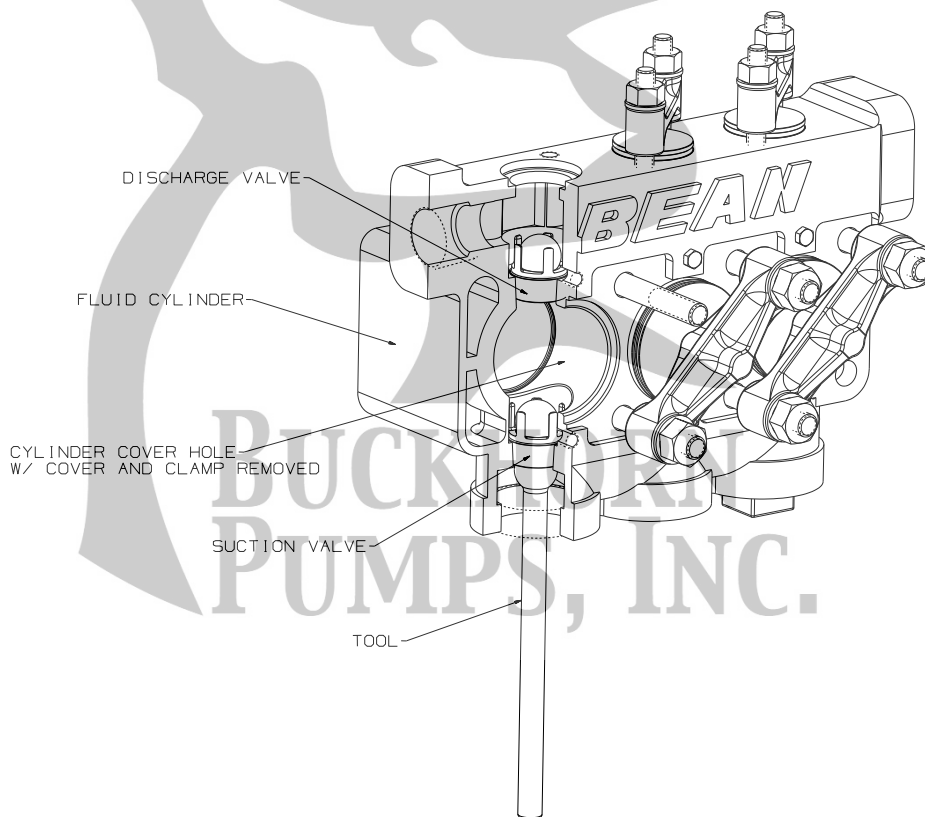

Figure 4: Using the Installation and Knock Out Tool



NOTE

If the discharge valves need to be serviced, but the suction valves do not, the Installation and Knock Out tool may be inserted through the cylinder cover hole to knock loose only the discharge valve (topmost valve, pictured above). The tool will be at an angle so care must be taken to avoid injury or damage to the tapered seat in the tool is not properly positioned against the bottom of the valve seat.

10.3.2 Replacing W11 Disc Type Valves

The disc type valve used in W11 FMC pump models is shown in Figure 5. The standard construction of stainless steel seat, disc, and stop are a relatively simple design with excellent performance and ample life. These valve assemblies come pre-assembled from the factory and should not need to be disassembled.

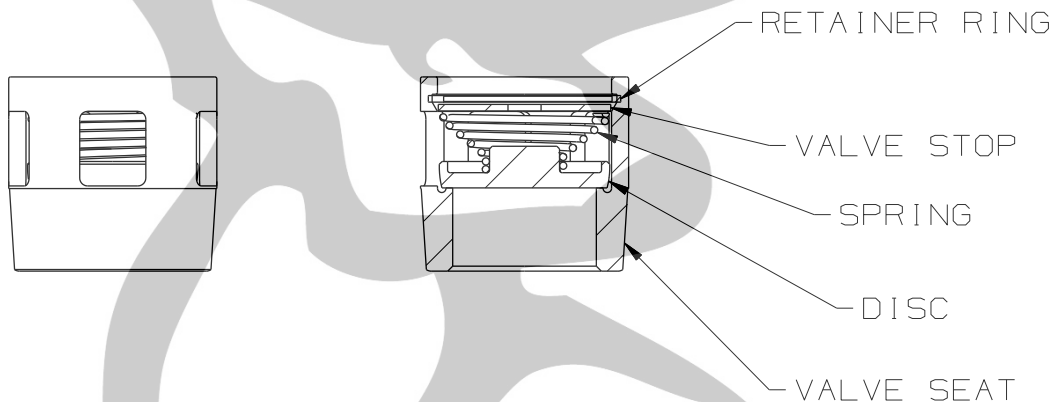

Figure 5: Typical W11 Disc Valve Assembly

When a worn or malfunctioning valve is detected, it must be replaced. With disc valves, the most difficult task associated with replacing a valve is the removal of the seat from the fluid cylinder. The seats are held into the fluid cylinder with a matching force fit taper.

10.3.3 Valve Removal and Installation Tools

There are two Knock Out tools available for removing valves from W11 pumps. The [P534695](#) Small Ball Knock Out tool is the preferred tool for W11 pumps with ball valves. The [P534694](#) Large Ball Knock Out tool is designed for the disc valves in the W11 pumps. The valves and appropriate tools are listed in Table 9.



Figure 6: Illustration of the [P534694](#) or [P534695](#) Ball Valve Knock Out Tools

All Knock Out tools are used as illustrated in Figure 4, Section 10.3.1. The [P534694](#) or [P534695](#) ball type tools are used with the ball end positioned against the bottom of the valve seat.

BUCKHORN
PUMPS, INC.

10.3.4 Installation of Disc Valves

The suction valves must be installed before the discharge valves can be installed. The following reassembly procedure is applicable for both.

1. Select a new valve assembly and check to ensure the taper on the valve is clean.
2. Carefully clean the taper in the fluid cylinder and on the valve seat with a cleaning solution and a clean cloth. Small scratches can be removed with steel wool or 100 grit emery paper. Remove all dirt, grease, oil, water, or any other contaminants from the surfaces. Do not oil the seats or the seating surfaces in the fluid cylinder. Confirm they are dry before installation.
3. Position the valve assembly directly over the mating taper in the fluid cylinder.
4. Let the valve assembly drop into the taper. Check that the seat is sitting in the taper properly and not cocked to one side. If the seat drops straight, it will seize on the taper. When correctly seated, it cannot be pulled up by hand.
5. Place the appropriate installation tool on the top surface of the valve assembly. The suction valves will require tool [P534699](#) for the larger valves which can be struck using a Ball Valve Knock Out Tool, [P534695](#) or [P534694](#), until the valve is fully seated.
6. Repeat steps 1 through 5 for the discharge valve.



BUCKHORN
PUMPS, INC.

10.4 Servicing the Power End

10.4.1 Replacing Piston Rod Oil Seals



Ensure that all pressure inside the pump fluid cylinder has been bled off before starting any service work.

NOTE



ENSURE THAT THE POWER IS LOCKED OUT AND TAGGED OUT BEFORE SERVICING ANY PART OF YOUR FMC PUMP

CAUTION

1. The piston rod oil seals (8) retain oil in the power end and prevent contamination from entering the power end by way of the piston rods. The fluid end and cylinders must be removed as outlined in the previous sections to provide access to these seals.
2. Rotate the seal retainer (23) counter clockwise until it is unthreaded from the frame, then slide off the rod. Use a screwdriver and mallet to unthread this seal retaining nut similarly to the example pictured to the right.
3. Pull the seal holder (7) out of the pump frame and slide off of the rod. It may be necessary to use two screwdrivers to slide the seal holder out of the recess. A slight rocking motion on the seal holder may aid in removal.
4. Remove the seal retainer gasket (24) from the power frame. Inspect the seals (8) and note the orientation of the seals prior to removal. The seals may now be removed from the seal holder and discarded.
5. To rebuild, insert new seals (8) in the seal holder (7), ensuring they are oriented in the same manner as the ones that were removed. Do not reuse seals that have



been removed from the pump. Replace the seal retainer gasket (24) if it shows signs of deformation or damage.

6. Wrap tape or other material over the exposed piston rod threads to protect the new seal lips from damage. Lightly oil piston rod after applying tape to the threads. Install the seal retainer gasket then slide the seal holder over the protected threads and into the pump frame. Care must be taken to ensure the seal lips are not folded or cut when passing over the ends of the rod.
7. Ensure that the gasket (24) and seal holder (7) are in place, install the seal retainer (23) and tighten until it bottoms out. Do not over tighten as it can damage the seal retainer gasket.
8. Remove the protective material that is covering the rod threads. Rebuild the remainder of the pump as outlined in previous sections. Torque all fasteners as outlined in the Fastener Torque Requirements, Section 11.0 of this manual.

10.4.2 Rebuilding the Power End

1. Remove magnetic pipe plug (32) to allow all oil to drain from power frame (1).
2. Remove all rear cover cap screws (30). Remove the back cover (12) and back cover gasket (13) from the power frame.

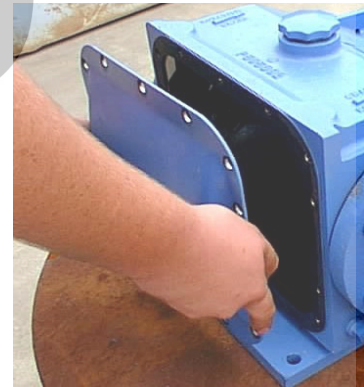

Removing the fluid cylinder simplifies crankshaft removal on W11 pumps

NOTE

3. Remove the end cap of each connecting rod (3) by removing the two hex nuts that hold each end cap to the connecting rod body. The cap can be removed from the body by tapping on the cap screws with a rubber mallet and then tapping on the end cap to loosen. Be sure to not damage the threads on the cap screws.

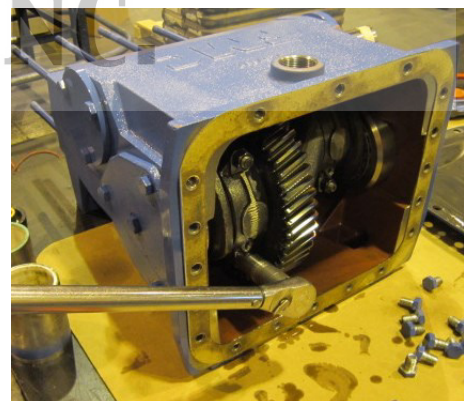

4. Slide the two rod bearing halves (4) from each connecting rod (3). Note that these parts sometimes adhere to the pins (journals) on the crankshaft (2).



NOTE

Connecting rods and caps are matched sets and must always be reassembled with their original mate in the same orientation. Note the numbered codes stamped on each half of the connecting rod assemblies and make certain they are installed as matched set and in the same orientation when reassembling the pump.

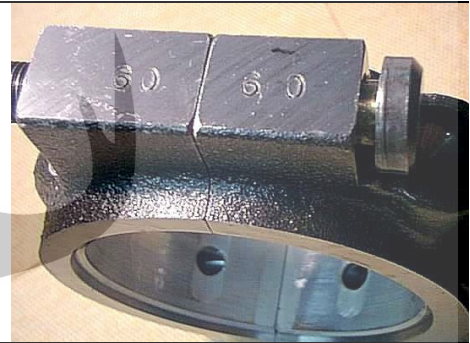

5. Remove the pinion shaft bearing housing hex head cap screws (29), the left and right pinion housings (18 and 19), and pinion gaskets (21) from the power frame. The gaskets may adhere to the power frame surface and can be left in place if they are not damaged. It may be necessary to tap on the housings with a rubber mallet to free them from the pump frame.



6. The pinion shaft (17) with bearings may then be removed from the drive side by using a brass rod (or other soft material) and mallet to drive the shaft out.
7. To remove the piston rod seals, refer to Section 10.4.1, "Replacing Piston Rod Oil Seals."
8. Push the connecting rod (3) and crosshead assemblies (6) as far forward into the power frame as possible to provide clearance for the crankshaft. The connecting rod bolts should be removed completely to provide additional clearance when removing the crankshaft and to reduce the possibility of damage to the crankshaft journals.

Installation Tip: Mark the bearing housings and power frame for installation in the original position.

9. Remove the hex head cap screws (29), bearing housings (9), gaskets (10), and shims (11) from both sides of the pump. Count and record the shims on each side to facilitate reassembly. The gaskets may adhere to the power frame surface and can be left in place if they are not damaged. The bearing cups (16) will remain in the bearing housing.

10. To remove the crankshaft, work the crankshaft to the left when viewing from the rear opening of the power frame. The bearing cone (15) will be partially out of the bearing housing opening. The throws or journals may have to be rotated as the crank is removed to clear the connecting rods. Slip the crankshaft end on the right out the back of the power frame and remove. The crankshaft should be handled carefully to prevent the critical bearing surfaces from being scratched or damaged.



11. Bearing cones (15) may be removed from the crankshaft using an automotive type bearing puller. Bearing cups (16) can be removed from the bearing housing using a puller if a sufficient lip is available for the puller arms to grab. An alternate procedure involves running a weld bead around the inside surface of the cup. When cool, this will reduce the interference between the cup and bearing housing enough to free the cup. If either the cup or cone is replaced, the corresponding cup or cone should be replaced as they are a matched set.



12. Pull the connecting rod/crosshead assemblies (3 and 6) from the power frame. Mark each connecting rod and crosshead assembly to ensure they are reassembled into the same bore from which they were removed.



13. Remove the set screws (25) and slide the wrist pin (5) out of the crosshead (6) if crosshead or connecting rod (3) requires service. Keep components matched together.

14. Inspect all components for signs of wear or damage and replace if necessary. Carefully check the crankshaft bearing surfaces for pits, scratches, or other signs

of wear. The connecting rod bearings should be inspected for deep scratches or the wear on top metal surface.

15. If damaged, replace the pinion oil seal (22) using a screwdriver or similar tool.
16. Thoroughly clean all parts with solvent and apply a thin coat of oil before reassembly.
17. Tapered roller bearing cones (15) must be heated to aid in assembly onto the shaft. Always observe proper safety procedures and use heat resistant tools and gloves when handling hot parts. There are a number of recommended methods for heating bearings. Electric ovens or electrically heated oil baths may be used, but only when accompanied by proper thermostatic control.
18. To replace the tapered roller bearings on the crankshaft, heat the cones to a maximum of 300° F (149° C). Slide them down the shaft until they are fully seated against the shoulder. The hot cone may pull away from the shoulder unless it is held in position until it cools enough to grab the shaft. Use a .001" thick feeler gauge to ensure the cone is fully seated against the shoulder after parts have cooled.
19. Use a press to seat the new cups (16) into the bearing housings. Never use new bearing cones with old bearing cups. Always use matched sets from one manufacturer.
20. Reassemble the crosshead assemblies and connecting rods. Ensure that the set screws (25) retaining the wrist pins (5) are in place if they were removed for repair or inspection of the wrist pin bushings. The set screw must engage the flat on the wrist pin. Refer to Section 11.0 for torque specifications.
21. Push the crosshead/connecting rod assemblies fully forward in power frame to provide maximum clearance for the crankshaft. Ensure crosshead assemblies are replaced in the same orientation and in the same cylinder bore from which they came.



The oil cup pocket feeding lubricant to the wrist pin bushing is on the top of the connecting rod and should be in the up position.

NOTE

22. Install crankshaft in the power frame. Be sure not to scratch the bearing surfaces of the crankshaft.
23. Inspect the o-ring (27) or gasket (10) that seals the bearing housing and replace if damaged. Reinstall the shims (11) and bearing housings. As a starting point, install the same number of shims that the pump originally had prior to service work. Refer to Section 11.0 of this manual for Fastener Torque Requirements.

24. Replace the rod bearings (4) in the connecting rod and connecting rod caps. Ensure that the rod caps are properly assembled with their mating connecting rod. Torque the fasteners holding the end caps to the mating rod per the values given in Fastener Torque Requirements, Section 11.0 of this manual. Use back and forth pattern tightening with a torque wrench. After the cap screws are torqued, a light strike to the cap with a rubber hammer will help properly seat the rod bearings. Recheck torque after seating the rod bearings.
25. A dial indicator must be used to properly adjust the endplay of the crankshaft. Improper adjustment may result in excessive temperature, noise, and reduced bearing life. FMC recommends between .002" tight to .003" loose of internal axial clearance (end play) when properly assembled. The final adjustment must be verified using a dial indicator as indicated in the following steps.
26. Turn the crankshaft more than two revolutions to ensure the connecting rods are loose and that there is no binding in the rod bearings. Also check that the wrist pin joints are free and the crossheads move freely in the power frame.
27. Move the crankshaft to one side of the power frame using a light tap from a rubber mallet or a pry bar. Rotate the crankshaft several turns and repeat the light taps from a rubber mallet or the use of a pry bar to ensure the crankshaft is to one side
28. Mount indicator base on the power frame with the indicator tip on a machined shoulder surface of the crankshaft (do not measure from a cast surface) and the axis of the indicator parallel to the crankshaft.
29. Set the dial indicator to zero.

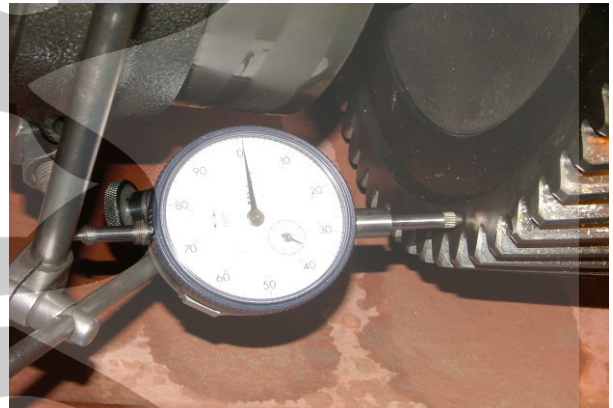

BUCKHORN PUMPS, INC.

30. Move the crankshaft back over to the opposite side and read bearing endplay as total indicator movement. Rotate the crankshaft several turns and repeat the effort to move the crankshaft in the direction described in this step. Repeat the dial indicator measurement. Remove or add shims as necessary to achieve proper endplay (.002" tight to .003" loose). Distribute shims equally on both bearing housings. Verify the endplay with the dial indicator per this procedure described before final assembly.



31. Install the piston rod seal holder and seal retainer in the power frame per instructions in Section 10.4.1. The crankshaft should turn freely.
32. Complete reassembly of pump.
33. Torque all fasteners as outlined in Fastener Torque Requirements, Section 11.0 of this manual.

BUCKHORN
PUMPS, INC.

11.0 Fastener Torque Requirements

NOTICE: No pump service procedure is complete without ensuring that the fasteners have been properly torqued. Failure to properly tighten the pump bolts could cause the pump to leak or fail. Always use a calibrated torque wrench during the installation of all critical fasteners listed in Table 6 below. Values are in foot-pounds (Ft-lb) and Newton meters (N-m). Typical sizes are shown in Table 6 below. Refer to Table 7 for other sizes that may be used depending upon application.

Table 6: Torque Values for Critical Pump Fasteners

POWER END				
Item No.	Component Description	W11		
		Size	Ft-lb	(N-m)
3	Connecting Rod Bolts	0.500	65	88
23	Piston Assembly Nut	0.750	35	47
53	Piston Rod Hex Nut	0.500	35	47
29	Bearing Housing Screws	0.500	60	81
29	Pinion Housing Screws	0.500	60	81
30	Back Cover Bolts	0.500	30	41
25	Cross Head Set Screw	0.313	15	20

FLUID END				
Item No.	Component Description	W11		
		Size	Ft-lb	(N-m)
52	Cylinder Attach/Clamp Nut *	0.625	120	163
51	Valve Cover Nut *	0.500	60	81

* For XYLAN coated studs and nuts, use Table 7.

** Refer to Figure 2 and Figure 3 for item numbers.

Table 7: Torque Values for Xylan-Coated Fasteners

SIZE	0.500	0.625	0.750	0.875	1.000	1.125	1.250
Ft-lb	40	80	135	215	320	460	630
(N-m)	54	108	183	292	434	624	854

12.0 Critical Clearances

When maintenance which requires disassembly of the power end is performed, the following clearances should be checked to see if they are within factory specification or within maximum allowable limits. Additional clearance is allowed for component wear. This additional clearance is a maximum of .002 inches of total diametric wear that can be added to the clearance values in Table 8. For radial clearance, use ½ of the total diametric value.

Table 8: Clearance Chart

DESCRIPTION	W11
Crankshaft Throw Diameter (Stroke)	2.75
Crankshaft Pin or Journal (OD)	3.4990/3.4995
Connecting Rod / Crank Clearance (Max. Total)	0.003
Crosshead Diameter (OD)	3.121/3.123
Crosshead Cylinder Bore (ID)	3.1245/3.1260
Crosshead to Bore Clearance (Max. Total)	0.005
Wrist Pin Bushing Bore (ID)	1.2505/1.2515
Wrist Pin to Bore Clearance (Max. Total)	0.002

* Clearances shown are total diametric values: For radial clearance, use ½ of the value shown.

** All dimensions below in inches

Metric Conversion: 1 inch = 25.4 mm
 1 mm = 0.03937 inches

**BUCKHORN
PUMPS, INC.**

13.0 Special Service Tools

Table 9: Special Service Tool Guide

W11 PUMPS					
	TYPE	ASSY PART No.	SIZE	REMOVAL TOOL	INSTALLATION TOOL
Valve Installation and Removal Tools	Disc	1278104	1.563 G.L. / 1.09 ID	P534694 (Large Ball)	P534694 (Large Ball) and P534699 (Small Valve Tool)
	Ball	1284740	1.563 G.L. / .937 ID	P534695 or P534694 (Large Ball)	P534695 (Small Ball)
Piston Servicing Tools	W1122	All W1122	2.84 OD	A5049 (Piston Nut Wrench)	A5049 (Piston Nut Wrench)
	W1118	All W1118	2.25 OD		

NOTE: G.L. = Gage Line



14.0 Troubleshooting Your FMC Pump

This chart is designed to aid in the solution of pump and pump system problems. Once the problem has been identified, work through the possible causes and solutions until the problem has been corrected.

Table 10: Troubleshooting W11 Pumps

SYMPTOM	POSSIBLE CAUSE	REMEDY
No flow from pump	<ul style="list-style-type: none"> -No liquid in reservoir (tank) -Inlet line valve closed -Inlet strainer is totally clogged with debris -Crankshaft is not turning 	<ul style="list-style-type: none"> -Ensure lines are connected and fill tank -Ensure lines are connected and open valve -Clean or replace strainer -Check for power to drive and drive connections
Insufficient pressure from pump (ONLY)	<ul style="list-style-type: none"> -Pump speed is too low -Relief valve improperly adjusted or worn -Insufficient system resistance (worn nozzle) -Worn check valves -Excessive leakage from pump seals 	<ul style="list-style-type: none"> -Check belt tightness or power to motor -Check relief valve and adjust setting -Properly service system -Inspect check valves and repair or replace -Adjust or replace packing or damaged parts
Insufficient flow from pump (ONLY)	<ul style="list-style-type: none"> -Pump speed is too low -Relief valve improperly adjusted or worn -Worn pump valves -Excessive leakage from pump seals -Plunger or piston worn -Valve seat washed out in fluid cylinder 	<ul style="list-style-type: none"> -Check belt tightness or power to motor -Check relief valve and adjust setting -Inspect pump valves and repair or replace -Adjust or replace packing or damaged parts -Replace plunger or piston -Repair or replace fluid cylinder
Insufficient flow or pressure AND rough operation (pump pounds or vibrates)	<ul style="list-style-type: none"> -All pump cylinders not primed -By-pass or relief is piped back to suction -Inlet line too long or too small in diameter -Insufficient NPSHA -Air leaks in suction line or fittings -Vortex in tank near inlet pipe opening -Air entering booster pump -Pump valve stuck open or closed -Valve assembly damaged or unseated -Valve seat washed out in fluid cylinder -Gas pocket formation from high spots in suction 	<ul style="list-style-type: none"> -Prime all chambers -Pipe back to reservoir (tank) -Increase suction pipe size -Provide more NPSH -Correct installation to stop leaks -Increase submergence or baffle to stop vortex -Correct installation of booster pump -Clean and deburr valve -Properly seat or repair valve -Repair or replace fluid cylinder -Correct suction line installation

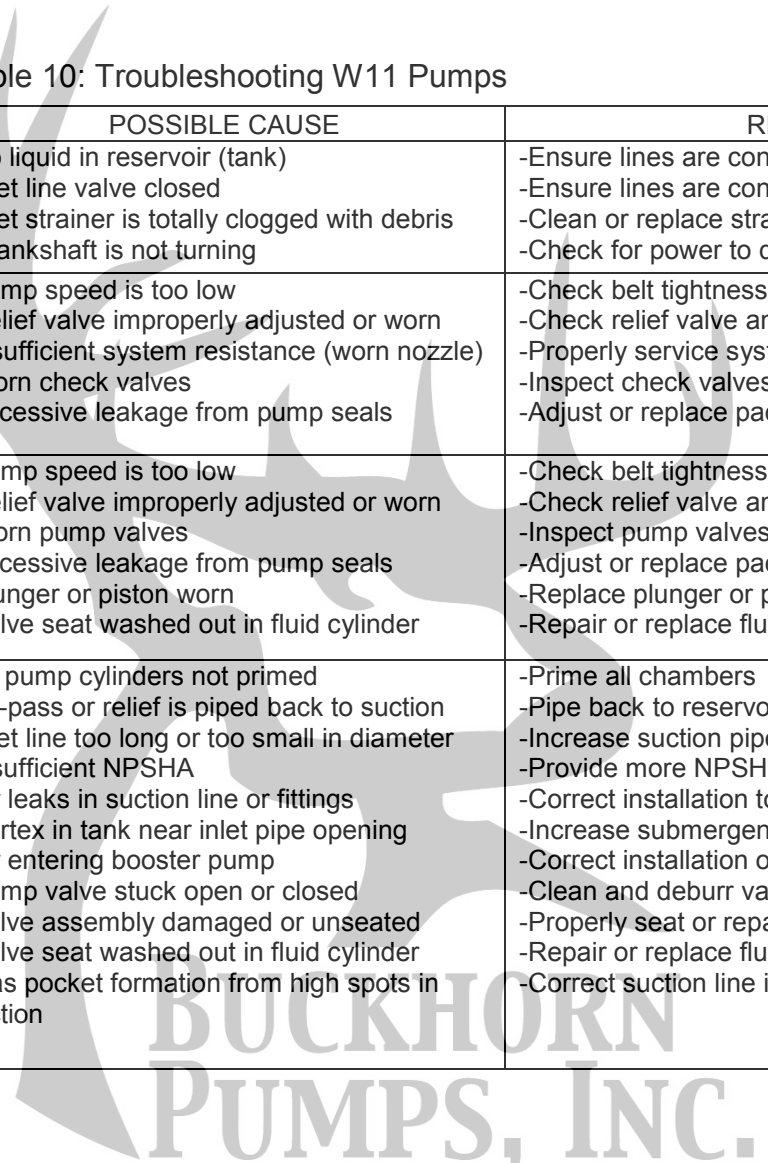

<p>Pump runs rough, knocks, or vibrates (ONLY)</p>	<ul style="list-style-type: none"> -Broken or weak valve spring -Valve damaged or unseated -Loose plunger, piston, or rod -Low oil level in power end -Excessive connecting rod bearing clearance -Excessive main bearing clearance -Worn wrist pin or bearing -Pump running backward -Loose sheaves or bushings (v-belt drive) -Gear tooth cracked or broken -Insufficient NPSHA -Excessive acceleration head in suction line -Pulsation dampener improperly charged -Inlet line too long or too small in diameter -Worn piston seal allows air ingress (usually observed when booster not used) 	<ul style="list-style-type: none"> -Replace valve spring -Repair/replace valve or re-seat -Tighten loose components -Fill to proper level -Check cap torque or replace bearings -Adjust end-play -Replace worn components -Correct rotation -Tighten loose components -Replace gear -Provide more NPSH -Install suction stabilizer -Charge to proper pressure -Increase suction pipe size -Replace piston seal
<p>Rapid suction pressure fluctuation</p>	<ul style="list-style-type: none"> -Pump cavitation -Air is entering suction line 	<ul style="list-style-type: none"> -Increase suction size or NPSH -Correct installation to stop leaks
<p>Piping vibration</p>	<ul style="list-style-type: none"> -Same as Pump runs rough above -Excessive pressure variation in discharge -Piping inadequately supported -Excessive short-radius elbows or tees 	<ul style="list-style-type: none"> -See above -Install discharge pulsation dampener -Install supports at proper locations -Correct installation to minimize turns and short-radius fittings
<p>Pump requires excessive power</p>	<ul style="list-style-type: none"> -Discharge pressure too high -Plungers or pistons too large -Speed too high -Packing too tight -Misaligned coupling -Belts too tight -Power end bearings too tight -Low motor voltage 	<ul style="list-style-type: none"> -Reduce system back-pressure or relief valve -Install smaller plungers to reduce flow -Reduce speed -Loosen gland (Adjustable packing) -Correct alignment -Correctly adjust belt tension -Increase end-play -Supply correct voltage
<p>Power end overheats (over 180° F) and/or reduced power component end life</p>	<ul style="list-style-type: none"> -Discharge and/or suction pressure too high -Oil level too high or too low -Contaminated power end oil -Incorrect oil viscosity or grade -Misaligned coupling -Belts too tight -Pump running backward -Pump located too close to heat source -Worn or damaged power end bearings 	<ul style="list-style-type: none"> -Reduce pressure or reduce plunger size -Adjust to correct oil level -Refill with clean oil & eliminate contamination -Fill with correct oil -Correct alignment -Correctly adjust belt tension -Correct rotation -Remove heat source or insulate power end -Replace damaged bearings
<p>Crankshaft jerks or starts and stops rotation</p>	<ul style="list-style-type: none"> -Drive belts loose and slipping (if equipped) -System relief valve pressure set too high -Discharge line blocked or partially blocked 	<ul style="list-style-type: none"> -Correctly adjust belt tension -Reduce relief valve pressure setting -Clear obstructions from piping system
<p>Fluid leaking from pump</p>	<ul style="list-style-type: none"> -Piston cups are worn -Piston to rod o-ring damaged -Fluid cylinder bolts not properly tightened -Fluid cylinder o-rings (or gaskets) damaged 	<ul style="list-style-type: none"> -Replace piston cup -Replace o-ring -Properly tighten and torque bolts -Replace damaged o-rings or gaskets

Reduced packing or piston cup life	<ul style="list-style-type: none"> -Highly abrasive particles in fluid -Packing or piston cups run dry -Incorrect packing or cups for fluid type -Inadequate packing lubrication -Pump was run dry for extended time -Plunger (or rod) misaligned to stuffing box -Worn plunger or cup holder -Worn cylinder liner bore -Packing gland too tight (adjustable) -Packing gland too loose (adjustable) -Too much packing in box -Broken or weak spring 	<ul style="list-style-type: none"> -Install strainer or filter -Correct problem & replace packing or cup -Change to correct packing or cup -Correct problem and replace packing -Correct problem and replace cups -Correct alignment -Replace plunger or cup holder -Replace cylinder liner -Properly adjust gland nut -Properly adjust gland nut -Correct installation problem -Replace spring
Reduced valve life	<ul style="list-style-type: none"> -Highly abrasive particles in fluid -Cavitation damage -Air leaking into suction line or stuffing box -Suction inlet insufficiently submerged -Relief valve or bypass piped to suction -Valve damaged by improper installation 	<ul style="list-style-type: none"> -Install strainer or filter -Correct problem and replace damaged valves -Correct problem and replace damaged valves -Increase submergence or baffle to stop vortex -Pipe back to reservoir (tank) -Replace damaged components
Cracked fluid cylinder or broken fluid end bolts	<ul style="list-style-type: none"> -Discharge pressure too high -Hydraulic shock (cavitation or entrained air) -Discharge valve stuck closed -Fluid freezing in fluid cylinder -Material or manufacturing defect -Bolt or nut not properly torqued -excessive piping loads on fluid end 	<ul style="list-style-type: none"> -Reduce system back pressure or relief valve -Correct piping system problem -Replace damaged components -Change procedure to drain fluid when cold -Replace defective component -Replace fluid cylinder and properly torque -Add supports to piping
Broken crankshaft or connecting rod	<ul style="list-style-type: none"> -Discharge pressure too high -Suction pressure too high -Fluid freezing in fluid end -Hydraulic shock due to cavitation -Material or manufacturing defect 	<ul style="list-style-type: none"> -Reduce system back pressure or relief valve -Reduce suction pressure or plunger diameter -Change procedure to drain fluid when cold -Correct piping system problems -Replace defective components
Power end oil is contaminated	<ul style="list-style-type: none"> -Extended operation with failed piston cup -Hi-pressure wash wand near breather or seals -Deflector shields are missing or damaged -Crosshead extension seals damaged -Excessive capacity in liner wash system -Improperly adjusted liner wash nozzle 	<ul style="list-style-type: none"> -Replace piston cup and improve monitoring -Provide shields to protect breather and seals -Repair or replace deflector shields -Replace oil seals -Reduce capacity in liner wash system -Adjust liner wash nozzle



15.0 Ordering Parts

Service parts are available through FMC's worldwide network of distributors or from the original supplier for the equipment that the pump is a component of. If unsure where to purchase parts, contact FMC customer service for the location of an authorized parts retailer in your area.

Always insist on genuine FMC replacement parts.

Use the assembly drawing and bill of material included with this manual to determine the components and corresponding part numbers required to service the pump. Make sure that the part number on the drawing or bill of material matches the part number of the pump requiring parts.

When placing orders for parts, always reference the part number and serial number of the pump. These numbers can be found stamped on the metal name tag affixed to the power end of every pump. By referencing these numbers you can ensure that the components you receive work as intended with your pump.

Be sure to inquire about any special service tools or complete maintenance kits.



BUCKHORN
PUMPS, INC.

16.0 Glossary of Commonly Used Terms

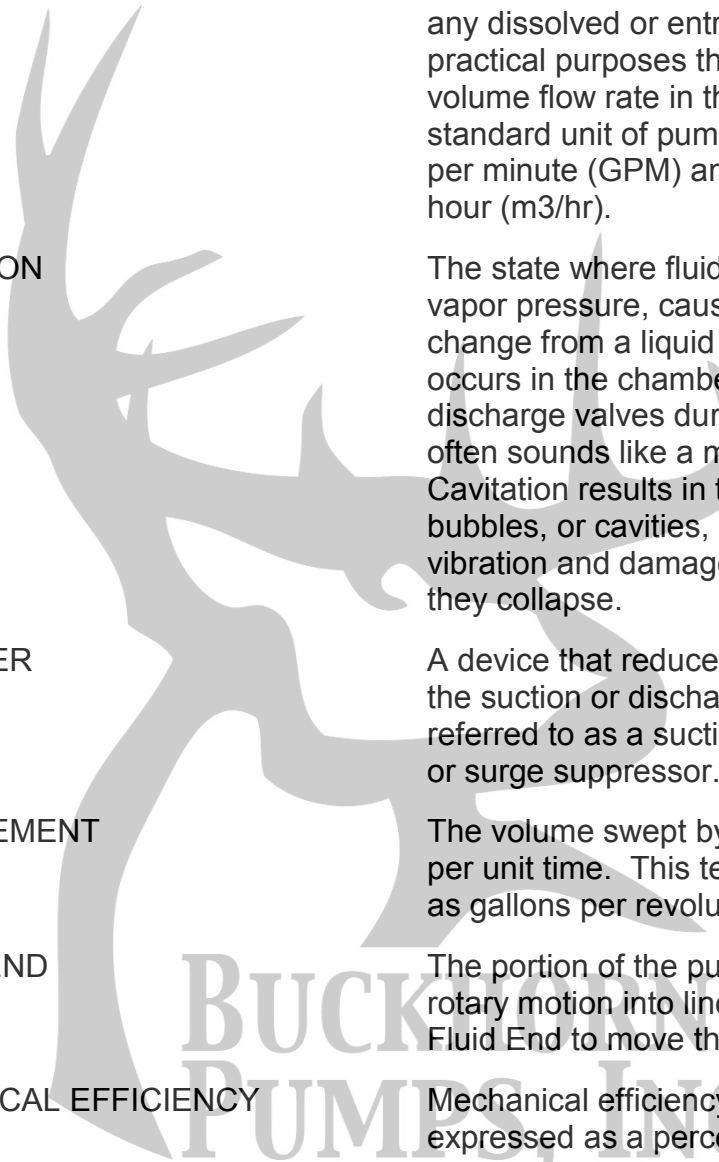

CAPACITY	The total volume throughput per unit of time at suction conditions. It includes both liquid and any dissolved or entrained gases. For all practical purposes this can be considered the volume flow rate in the suction pipe. The standard unit of pump capacity is U.S. gallons per minute (GPM) and metric cubic meters per hour (m ³ /hr).
CAVITATION	The state where fluid pressure drops below vapor pressure, causing the liquid to begin to change from a liquid to a gas and boil. Usually occurs in the chamber between the suction and discharge valves during the suction stroke, and often sounds like a mechanical knock. Cavitation results in the formation of gas bubbles, or cavities, in the fluid that cause vibration and damage to components when they collapse.
DAMPENER	A device that reduces pressure pulsations in the suction or discharge piping. This may be referred to as a suction stabilizer, accumulator, or surge suppressor.
DISPLACEMENT	The volume swept by all pistons or plungers per unit time. This term is typically expressed as gallons per revolution.
POWER END	The portion of the pump that converts supplied rotary motion into linear motion used by the Fluid End to move the pumpage.
MECHANICAL EFFICIENCY	Mechanical efficiency (ME) is the ratio, expressed as a percentage, of pump power output to the pump power input. The mechanical efficiency of reciprocating pumps is very high, typically 85% to 90%.
VOLUMETRIC EFFICIENCY	Volumetric efficiency (VE) is the ratio of actual pump capacity output to theoretical displacement. The volumetric efficiency is

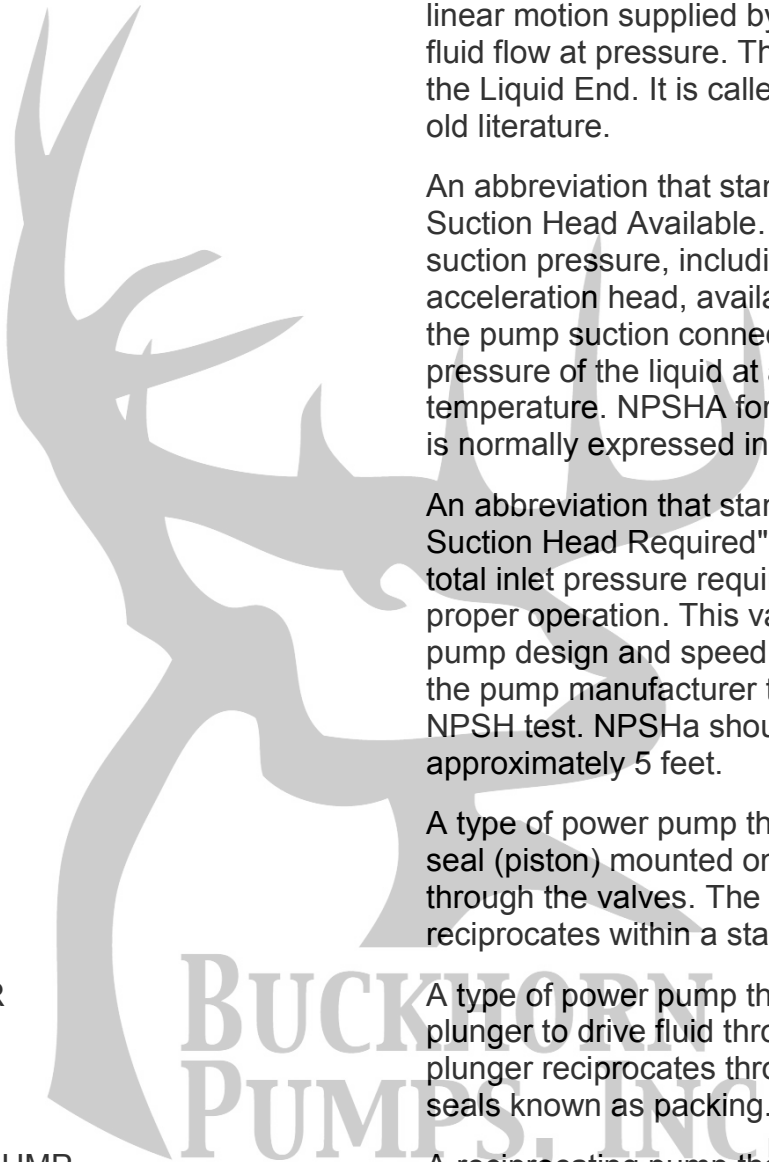

	affected by the fluid being pumped and the discharge pressure.
FLOODED SUCTION	Implies that the level of liquid in the suction vessel is above the centerline of the suction port of the pump.
FLUID END	The portion of the pump that converts the linear motion supplied by the power end into fluid flow at pressure. This may also be called the Liquid End. It is called a valve chamber in old literature.
NPSHa	An abbreviation that stands for Net Positive Suction Head Available. NPSHA is the total suction pressure, including allowance for acceleration head, available from the system at the pump suction connection, minus the vapor pressure of the liquid at actual pumping temperature. NPSHA for a reciprocating pump is normally expressed in units of feet of water.
NPSHr	An abbreviation that stands for "Net Positive Suction Head Required". This is the minimum total inlet pressure required by the pump for proper operation. This value is a function of pump design and speed and is determined by the pump manufacturer through a specific NPSH test. NPSHa should exceed NPSHr by approximately 5 feet.
PISTON	A type of power pump that uses a cylindrical seal (piston) mounted on a holder to drive fluid through the valves. The piston seal reciprocates within a stationary cylinder.
PLUNGER	A type of power pump that uses a cylindrical plunger to drive fluid through the valves. The plunger reciprocates through a stationary set of seals known as packing.
POWER PUMP	A reciprocating pump that drives the pumping element(s) using a slider crank mechanism. Power pumps are piston, plunger, or diaphragm type. All require a driver with a rotating shaft, such as a motor or engine, as a power source.

POWER FRAME

The major portion of a power pump that encloses and supports all other components of the power (or drive) end. It is called a pump case in old literature.

STROKE LENGTH

The length of one complete, unidirectional motion of the piston or plunger. Stroke length is usually expressed in inches.

PUMP VALVE

A check valve that allows flow of liquid in one direction. FMC pumps have a series of two valves, one suction (inlet) and one discharge, per pumping cylinder.



17.0 Reference Information

Use the following section to record key information about your specific pump model. Information such as part and serial numbers will be needed when ordering service parts. This data may be found stamped on the metal nameplate located on the pump power frame. This area may also be used to make notations about special parts, procedures, phone numbers, or other important information related to your pump.

Pump Model _____

Part Number _____

Serial Number _____

Rated Pressure _____

Rated Capacity _____

Rated Speed _____

Notes:



