



MYERS® APLEX SERIES

MODELS

MA-155L, MA-155M, MA-155M-HD,
SC-230,
RO-261

TRIPLEX PUMPS

INSTALLATION AND SERVICE MANUAL

NOTE! To the installer: Please make sure you provide this manual to the owner of the equipment or to the responsible party who maintains the system.

Engineering Data

MA-155L.....	3
MA-155M.....	4
MA-155M-HD.....	5
SC-230.....	6
RO-261.....	7

Dimensional Data8–9**Installation, Operation, Lubrication, Maintenance and Storage Instructions..... 10**

Safety.....	10
Storage.....	10
Pump Location and Piping Design.....	10
Suction Piping.....	10–11
Acceleration Head.....	11
Discharge Piping.....	11–12
Bypass Piping.....	12
Lubrication.....	12
V-Belt Drive.....	12, 14
Suggested Piping System for Plunger Pumps.....	13
Direction of Rotation.....	14
Automatic (Safety) Shutdowns.....	14

Crankshaft Assembly..... 14

General.....	14
Tapered Roller Bearings.....	14–15
Cup Installation.....	15

Installing Crankshaft..... 15

Shim Adjustment of Tapered Roller Bearings.....	15
Installation of Crankshaft Oil Seal.....	15
Disassembly.....	15–16

Connecting Rod, Crosshead, Extension Rod, Crosshead Pin and Wiper Box Assembly/Disassembly..... 16

General.....	16
Installing Wrist Pin Bushings.....	16
Bolting the Wrist Pin.....	17
Order of Assembly.....	17
Oil Scoop.....	18

Wiper Box Assembly..... 18

General.....	18
“Poly Pak” Seal.....	18
Mechanical Oil Seal.....	18
Inserting the Extension Rod.....	18

Stuffing Box, Packing and Plunger Assemblies..... 19

General.....	19
Spring Loaded Packing.....	19
J-Style Stuffing Box & Plunger Assembly (Styles 838 and 858).....	19–20
Inserting the Plunger.....	20

Installing the Gland.....	20
Installing the Stuffing Box.....	20
Connecting the Plunger.....	20
Packing.....	21
Plungers.....	21

Disc Valve Systems and Abrasion Resistant**Valve Construction..... 21**

General.....	21
Disc Valve and Abrasion Resistant Valve Construction.....	21–22
Setting the Valve Seat.....	22
Installing O-Rings, Abrasion Resistant Spring and Cage.....	22
Installing Disc, Spring, Disc Valves and Stem.....	22
Valve Spring Options.....	22–23
Valve Disc Options.....	23
Pulling the Valve Seat.....	23
Salvage of Worn Seats.....	23
Other Pump Brands.....	23

Trouble Location and Remedy.....24–26**Parts Lists.....26–31****Warranty..... 32**

MA-155L ENGINEERING DATA	
Power End	
Model Triplex Pump	MA-155L
Maximum Input HP at Speed	155 at 450 rpm
Rated Continuous Plunger Load	9,087 lbs.
Stroke	4-1/2"
Maximum Rated Continuous Speed	450 rpm
Normal Continuous Speed Range	150 to 420 rpm
Minimum Speed	100 rpm
Oil Capacity	22 U.S. Quarts
Viscosity, S.S.U. at 210°F	70 to 84
Power End Oiling System	Splash
Power Frame, One Piece	Cast Iron
Crosshead, Full Cylindrical	Cast Iron
Crosshead, Diameter x Length	5-3/4" x 6-3/16"
Crankshaft	Ductile Iron
Crankshaft Diameters: At Drive Extension	4.500/4.499"
At Tapered Roller Bearings	4-3/4"
At Crankpin Bearings, Diameter x Length	4-1/2" x 3-3/4"
Crosshead (Wrist) Pin, Case-Hardened and Ground	AISI 8620
Wrist Pin Bushing, SAE 660, Diameter x Width	2-5/8" x 3-5/8"
Main Bearings, Tapered Roller	Timken
Crankpin Bearings, Precision Automotive	Steel Backed, Babbitt-Lined
Extension (Pony) Rod: Diameter	2-1/2"
Material	17-4PH S.S.
Connecting Rod, Rifle Drilled	Ductile Iron
Average Crosshead Speed: At 450 rpm	338 fpm
Minimum Life Expectancy, Main Bearings, L ₁₀	60,000+hr
Liquid End	
Plunger Size Range, Diameter	2-3/4" Thru 4"
Maximum Continuous Working Pressure	1,389 psi
Hydrostatic Test: Discharge	2,175 psi
Suction Connection Size	6" ANSI
Hydrostatic Test, Suction	425 psi
Available Liquid End Materials, ASTM: Nickel Aluminum Bronze	B148-C955
Forged Steel Block	A105

MA-155L ENGINEERING DATA	
Liquid End (Continued)	
Plunger Type Rokide® Stainless Steel: Chromium Oxide-Coated	316 S.S.
Stuffing Boxes, Field-Removable and Replaceable: Aluminum Bronze	B148-C955
Carbon Steel	1020
Packing Types Available: Gland-loaded, Nonadjustable	Style 838
Spring-loaded, Cup-Type	Style 120X
Spring-loaded, Braided Teflon® & Kevlar®	Style 140/141
Spring-loaded, Garlock	Style 8921K
Studs, Material, ASTM	A193 Grade B7, Cadmium Plated
Nuts, Material, ASTM	A194 Grade 2
Seals, Stuffing Boxes, Valve Covers, Cylinder Heads	Buna-N
Bolting, High Strength, Heat Treated	Alloy Steel
Available Valve Types: Standard, Acetal Resin	Delrin®
Optional, Hardened and Lapped	17-4PH S.S.
Double Stem-Guided	17-4PH S.S.
Valve Seat, Liquid Passage Areas Plate (Disc) Valves, (Delrin® or S.S.)	6.54 sq. in.
Average Liquid Velocity, 4" Plungers at 450 rpm: Thru Seat	10.8 fps
Suction Manifold	3.7 fps
Discharge Manifold	16.1 fps
General	
Overall Dimensions: Length	55-3/4"
Width	43"
Height	22"
Approximate Weights: With Aluminum Bronze Liquid End	2,680 lbs.
With Forged Steel Liquid End	2,900 lbs.

MA-155M ENGINEERING DATA	
Power End	
Model Triplex Pump	MA-155M
Maximum Input HP at Speed	155 at 450 rpm
Rated Continuous Plunger Load	9,087 lbs.
Stroke	4-1/2"
Maximum Rated Continuous Speed	450 rpm
Normal Continuous Speed Range	150 to 420 rpm
Minimum Speed	100 rpm
Oil Capacity	22 U.S. Quarts
Viscosity, S.S.U. at 210°F	70 to 84
Power End Oiling System	Splash
Power Frame, One Piece	Cast Iron
Crosshead, Full Cylindrical	Cast Iron
Crosshead, Diameter x Length	5-3/4" x 6-3/16"
Crankshaft	Ductile Iron
Crankshaft Diameters: At Drive Extension At Tapered Roller Bearings At Crankpin Bearings, Diameter x Length	4.500/4.499" 4-3/4" 4-1/2" x 3-3/4"
Crosshead (Wrist) Pin, Case-Hardened and Ground	AISI 8620
Wrist Pin Bushing, SAE 660, Diameter x Width	2-5/8" x 3-5/8"
Main Bearings, Tapered Roller	Timken
Crankpin Bearings, Precision Automotive	Steel Backed, Babbitt-Lined
Extension (Pony) Rod: Diameter Material	2-1/2" 17-4PH S.S.
Connecting Rod, Automotive Type	Ductile Iron
Average Crosshead Speed: At 450 rpm	338 fpm
Minimum Life Expectancy, Main Bearings, L ₁₀	60,000+hr
Liquid End	
Plunger Size Range, Diameter	1-3/4" Thru 2-3/4"
Maximum Continuous Working Pressure	3,430 psi
Hydrostatic Test: Discharge	5,400 psi
Discharge Connection Size	6" ANSI 1500
Suction Connection Size	8" ANSI 150
Hydrostatic Test, Suction	425 psi
Available Liquid End Materials, ASTM: Nickel Aluminum Bronze Forged Steel Block	B148-C955 A105

MA-155M ENGINEERING DATA	
Liquid End (Continued)	
Plunger Type Rokide® Stainless Steel: Chromium Oxide-Coated	316 S.S.
Stuffing Boxes, Field-Removable and Replaceable: Aluminum Bronze Carbon Steel	B148-C955 1020
Packing Types Available: Gland-loaded, Nonadjustable Spring-loaded, Cup-Type Spring-loaded, Braided Teflon® & Kevlar® Spring-loaded, Garlock	Style 838 Style 120X Style 140/141 Style 8921K
Studs, Material, ASTM	A193 Grade B7, Cadmium Plated
Nuts, Material, ASTM	A194 Grade 2
Valve Cover and Cylinder Head Plugs	416 S.S. or 316 S.S.
Seals, Stuffing Boxes, Valve Covers	Buna-N
Bolting, High Strength, Heat Treated	Alloy Steel
Available Disc Valve Types: Standard, Acetal Resin Optional, Hardened and Lapped	Delrin® 17-4PH S.S.
Valve Set, Material, Hardened and Lapped	17-4PH S.S.
Valve Seat, Liquid Passage Areas: Plate (Disc) Valves, (Delrin® or S.S.)	3.9 sq. in.
Average Liquid Velocity, with 2-3/4" Plungers at 450 rpm: Thru Seat Suction Manifold Discharge Manifold	8.5 fps 3.9 fps 16.9 fps
General	
Overall Dimensions: Length Width Height	54-3/16" 43" 22"
Approximate Weights: With Aluminum Bronze Liquid End With Forged Steel Liquid End	2,500 lbs. 2,700 lbs.

MA-155M-HD ENGINEERING DATA	
Power End	
Model Triplex Pump	MA-155M-HD
Maximum Input HP at Speed	175 at 450 rpm
Rated Continuous Plunger Load	10,259 lbs.
Stroke	4-1/2"
Maximum Rated Continuous Speed	450 rpm
Normal Continuous Speed Range	150 to 420 rpm
Minimum Speed	100 rpm
Oil Capacity	22 U.S. Quarts
Viscosity, S.S.U. at 210°F	70 to 84
Power End Oiling System	Splash
Power Frame, One Piece	Cast Iron
Crosshead, Full Cylindrical	Cast Iron
Crosshead, Diameter x Length	5-3/4" x 6-3/16"
Crankshaft	Forged and Nitrided Alloy Steel
Crankshaft Diameters: At Drive Extension At Tapered Roller Bearings At Crankpin Bearings, Diameter x Length	4.500/4.499" 4-3/4" 4-1/2" x 3-3/4"
Crosshead (Wrist) Pin, Case-Hardened and Ground	AISI 8620
Wrist Pin Bushing, SAE 660, Diameter x Width	2-5/8" x 3-5/8"
Main Bearings, Tapered Roller	Timken
Crankpin Bearings, Precision Automotive	Steel Backed, Babbitt-Lined
Extension (Pony) Rod: Diameter Material	2-1/2" 17-4PH S.S.
Connecting Rod, Automotive Type	Ductile Iron
Average Crosshead Speed: At 450 rpm	338 fpm
Minimum Life Expectancy, Main Bearings, L ₁₀	50,000+hr
Liquid End	
Plunger Size Range, Diameter	1-3/4" Thru 2-3/4"
Maximum Continuous Working Pressure	3,430 psi
Hydrostatic Test: Discharge	5,400 psi
Discharge Connection Size	6" ANSI 1500
Suction Connection Size	8" ANSI 150
Hydrostatic Test, Suction	425 psi
Available Liquid End Materials, ASTM: Nickel Aluminum Bronze Forged Steel Block	B148-C955 A105

MA-155M-HD ENGINEERING DATA	
Liquid End (Continued)	
Plunger Type Rokide® Stainless Steel: Chromium Oxide-Coated	316 S.S.
Stuffing Boxes, Field-Removable and Replaceable: Aluminum Bronze Carbon Steel	B148-C955 1020
Packing Types Available: Gland-loaded, Nonadjustable Spring-loaded, Cup-Type Spring-loaded, Braided Teflon® & Kevlar® Spring-loaded, Garlock	Style 838 Style 120X Style 140/141 Style 8921K
Studs, Material, ASTM	A193 Grade B7, Cadmium Plated
Nuts, Material, ASTM	A194 Grade 2
Valve Cover and Cylinder Head Plugs	416 S.S. or 316 S.S.
Seals, Stuffing Boxes, Valve Covers	Buna-N
Bolting, High Strength, Heat Treated	Alloy Steel
Available Disc Valve Types: Standard, Acetal Resin Optional, Hardened and Lapped	Delrin® 17-4PH S.S.
Valve Set, Material, Hardened and Lapped	17-4PH S.S.
Valve Seat, Liquid Passage Areas: Plate (Disc) Valves, (Delrin® or S.S.)	3.9 sq. in.
Average Liquid Velocity, with 2-3/4" Plungers at 450 rpm: Thru Seat Suction Manifold Discharge Manifold	8.5 fps 3.9 fps 16.9 fps
General	
Overall Dimensions: Length Width Height	54-3/16" 43" 22"
Approximate Weights: With Aluminum Bronze Liquid End With Forged Steel Liquid End	2,500 lbs. 2,700 lbs.

SC-230 ENGINEERING DATA	
Power End	
Model Triplex Pump	SC-230
Maximum Input HP at Speed	310 at 450 rpm
Rated Continuous Plunger Load	18,320 lbs.
Stroke	4-1/2"
Maximum Rated Continuous Speed	450 rpm
Normal Continuous Speed Range	150 to 420 rpm
Minimum Speed	100 rpm
Oil Capacity	22 U.S. Quarts
Viscosity, S.S.U. at 210°F	70 to 84
Power End Oiling System	Pressure Lubrication System
Power Frame, One Piece	Cast Iron
Crosshead, Full Cylindrical	Cast Iron
Crosshead, Diameter x Length	5-3/4" x 6-3/16"
Crankshaft	Ductile Iron
Crankshaft Diameters: At Drive Extension At Tapered Roller Bearings At Center Bearings At Crankpin Bearings, Diameter x Length	4.500/4.499" 4-3/4" 9-3/8" 4-1/2" x 3-3/4"
Crosshead (Wrist) Pin, Case-Hardened and Ground	AISI 8620
Wrist Pin Bushing, SAE 660, Diameter x Width	2-5/8" x 3-5/8"
Main Bearings, Tapered Roller	Timken
Crankpin Bearings, Precision Automotive	Steel Backed, Babbitt-Lined
Extension (Pony) Rod: Diameter Material	2-1/2" 17-4PH S.S.
Connecting Rod, Automotive Type	Ductile Iron
Average Crosshead Speed: At 450 rpm	338 fpm
Minimum Life Expectancy, Main Bearings, L ₁₀	20,000+hr
Liquid End	
Plunger Size Range, Diameter	3-1/4" Thru 4"
Maximum Continuous Working Pressure	2,208 psi
Hydrostatic Test: Discharge	3,300 psi
Suction Connection Size	6" NPT
Hydrostatic Test, Suction	425 psi

SC-230 ENGINEERING DATA	
Liquid End (Continued)	
Available Liquid End Materials, ASTM: Steel	A105
Piston Type	Rubber
Liners	Hardened Steel
Plunger Type Rokide® Stainless Steel: Chromium Oxide-Coated	410 S.S.
Stuffing Boxes, Field-Removable and Replaceable: Aluminum Bronze Carbon Steel	B148-C955 1020
Packing Types Available: Gland-loaded, Nonadjustable Spring-loaded, Cup-Type Spring-loaded, Braided Teflon® & Kevlar® Spring-loaded, Garlock	Style 838 Style 120X Style 140/141 Style 8921K
Seals, Stuffing Boxes, Valve Covers, Cylinder Heads	Buna-N
Bolting, High Strength, Heat Treated	Alloy Steel
Available Valve Types: Abrasion Resistant	17-4PH S.S.
Valve Spring Material	Inconel®
Average Liquid Velocity, 4-1/2" Plungers at 450 rpm: Suction Manifold Discharge Manifold	3.7 fps 16.1 fps
General	
Overall Dimensions: Length Width Height	54-1/2" 43" 22"
Approximate Weights: With Forged Steel Liquid End	2,900 lbs.

RO-261 ENGINEERING DATA	
Power End	
Model Quintuplex Pump	RO-261
Maximum Input HP at Speed	200 at 450 rpm
Rated Continuous Plunger Load	11,750 lbs.
Stroke	4-1/2"
Maximum Rated Continuous Speed	450 rpm
Normal Continuous Speed Range	300 to 420 rpm
Minimum Speed	100 rpm
Oil Capacity	22 U.S. Quarts
Viscosity, S.S.U. at 210°F	70 to 84
Power End Oiling System	Splash
Power Frame, One Piece	Cast Iron
Crosshead, Full Cylindrical	Cast Iron
Crosshead, Diameter x Length	5-3/4" x 6-3/16"
Crankshaft	Ductile Iron
Crankshaft Diameters: At Drive Extension	4.500/4.499"
At Tapered Roller Bearings	4-3/4"
At Crankpin Bearings, Diameter x Length	4-1/2" x 3-3/4"
Crosshead (Wrist) Pin, Case-Hardened and Ground	AISI 8620
Wrist Pin Bushing, SAE 660, Diameter x Width	2-5/8" x 3-5/8"
Main Bearings, Tapered Roller	Timken
Crankpin Bearings, Precision Automotive	Steel Backed, Babbitt-Lined
Extension (Pony) Rod: Diameter	2-1/2"
Material	17-4PH S.S.
Connecting Rod, Rifle Drilled	Ductile Iron
Average Crosshead Speed: At 450 rpm	338 fpm
Minimum Life Expectancy, Main Bearings, L ₁₀	60,000+hr
Liquid End	
Plunger Size Range, Diameter	3-1/4" Thru 4"
Maximum Continuous Working Pressure	1,415 psi
Discharge Connection Size	3" ANSI
Hydrostatic Test, Discharge	2,125 psi
Suction Connection Size	6" ANSI
Hydrostatic Test, Suction	425 psi
Available Liquid End Materials, ASTM: Nickel Aluminum Bronze Stainless Steel Block	B148-C955 316 S.S.

RO-261 ENGINEERING DATA	
Liquid End (Continued)	
Plunger Type Rokide® Stainless Steel: Chromium Oxide-Coated	316 S.S.
Stuffing Boxes, Field-Removable and Replaceable: Aluminum Bronze Stainless Steel	B148-C955 316 S.S.
Packing Types Available: Gland-loaded, Nonadjustable Spring-loaded, Cup-Type Spring-loaded, Braided Teflon® & Kevlar® Spring-loaded, Garlock	Style 838 Style 120X Style 140/141 Style 8921K
Studs, Material, ASTM	A193 Grade B7, Cadmium Plated
Nuts, Material, ASTM	A194 Grade 2
Seals, Stuffing Boxes, Valve Covers, Cylinder Heads	Buna-N
Bolting, High Strength, Heat Treated	Alloy Steel
Available Valve Types: Standard, Acetal Resin Optional, Hardened and Lapped	Delrin® 17-4PH S.S.
Valve Seat, Liquid Passage Areas: Plate (Disc) Valves, (Delrin® or S.S.)	6.54 sq. in.
Average Liquid Velocity, 4" Plungers at 450 rpm: Thru Seat Suction Manifold Discharge Manifold	10.8 fps 3.7 fps 16.1 fps
General	
Overall Dimensions: Length Width Height	55-3/4" 43" 22"
Approximate Weights: With Aluminum Bronze Liquid End With Stainless Steel Liquid End	2,680 lbs. 2,900 lbs.

CROSS-SECTION

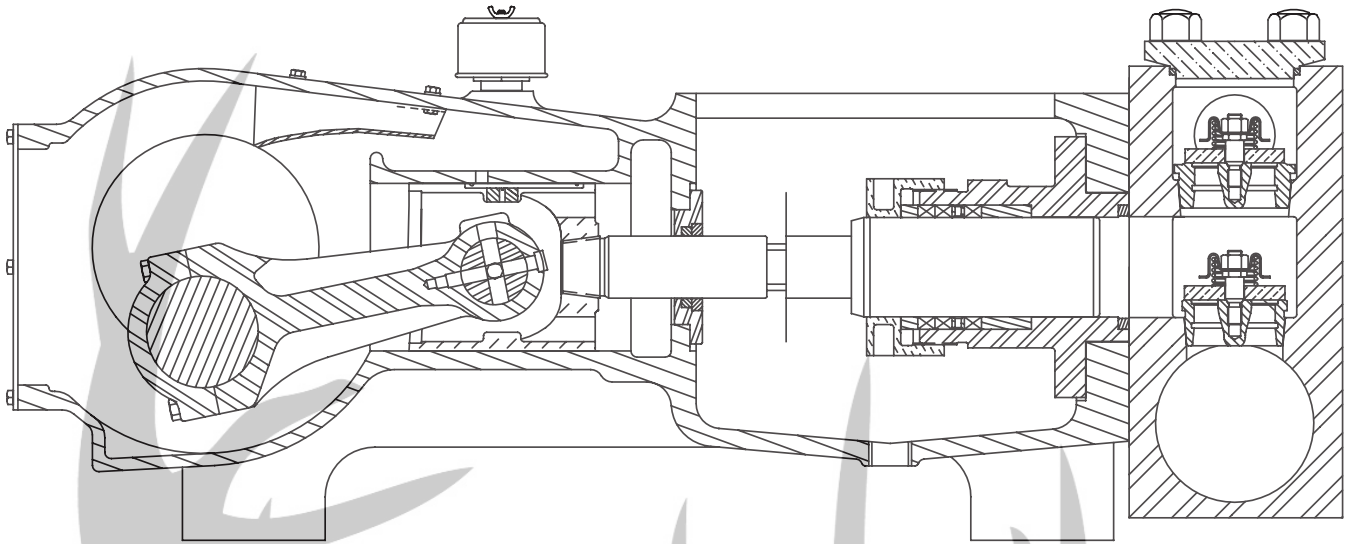

DIMENSIONAL DATA TABLE

Ref. No.	MA-155L	MA-155M	MA-155M-HD	SC-230	RO-261
A1	43	43	43	43	43
B1	54-1/2	53-7/8	53-7/8	—	54-1/2
B2	—	41-11/16	41-11/16	—	—
B3	20-13/16	19-3/4	19-3/4	—	20-13/16
B4	11	11	11	—	11
B5	10	9-1/8	9-1/8	—	10
B6	5-1/2	6-1/2	6-1/2	—	5-1/2
(B) Discharge Connections	3" ANSI 600 FF	2" ANSI 1500 FF	2" ANSI 1500 FF	—	3" ANSI 600 FF
(B) Suction Connections	6" ANSI 150 FF	4" ANSI 150 FF	4" ANSI 150 FF	—	6" ANSI 150 FF
C1	—	53-15/16	53-15/16	55-1/2	—
C2	—	41-3/4	41-3/4	—	—
C3	—	20-7/8	20-7/8	21-1/4	—
C4	11	11	11	11	11
C5	10	9-7/8	9-7/8	15	10
C6	5-1/2	5-1/8	5-1/8	—	5-1/2
(C) Discharge Connections	3" ANSI 600 RF	2" ANSI 1500 RF	2" ANSI 1500 RF	3" NPTF	3" ANSI 600 RF
(C) Suction Connections	6" ANSI 150 RF	4" ANSI 150 RF	4" ANSI 150 RF	6" NPTF	6" ANSI 150 RF

BUCKHORN PUMPS, INC.

DIMENSIONAL DRAWINGS

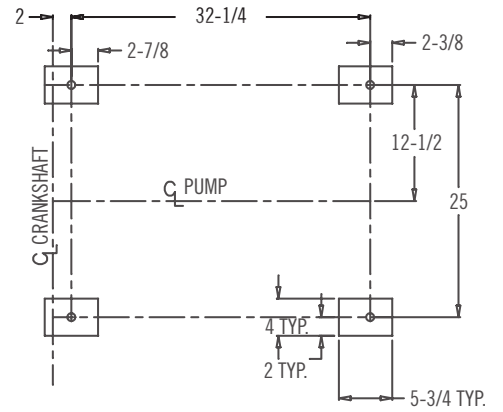
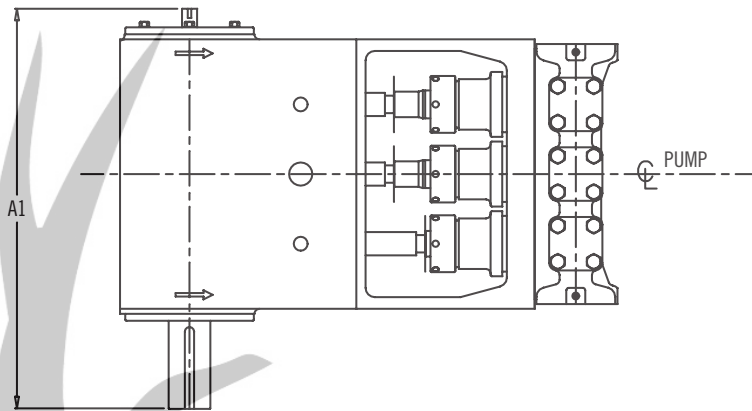

Cast Fluid End

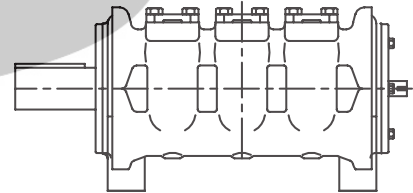
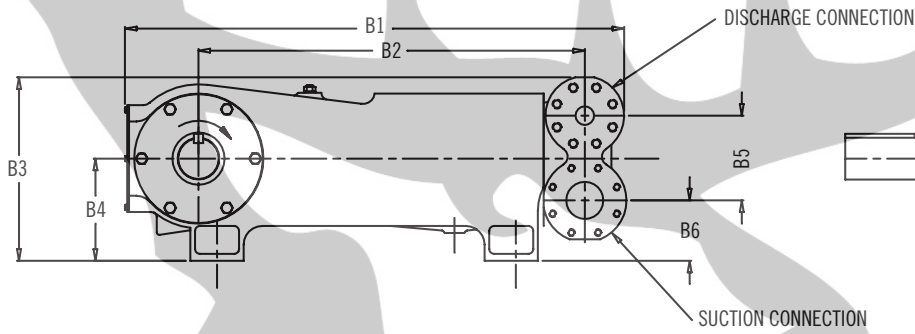

Block Fluid End

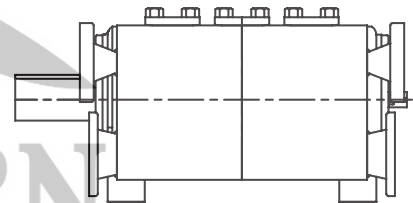
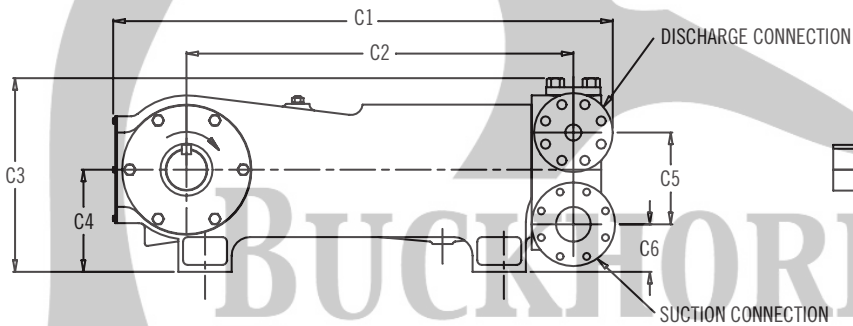

BUCKHORN
PUMPS, INC.

INSTALLATION, OPERATION, LUBRICATION, MAINTENANCE AND STORAGE INSTRUCTIONS

SAFETY

Electrical power or engine must be shut off completely before attempting service on the pump or its drive. Air surrounding the unit to be free of toxic, flammable, or explosive gases.

Tools needed should be planned for in advance (see valve seat pulling instructions), and should be clean and of adequate size. A torque-wrench will be required to tighten connecting rod cap screws.

A properly sized and set relief valve installed in the pump discharge system (ahead of any block valves) is necessary to protect personnel and to avoid dangerous overpressure. The relief valve set pressure should be not more than 25% above the design operating pressure and should discharge to tank or to the atmosphere (toward the ground), and must not be directed back to the pump suction system.

WARNING: *Improper use of this equipment could result in loss of life.*

CALIFORNIA PROPOSITION 65 WARNING:

WARNING: *This product and related accessories contain chemicals known to the State of California to cause cancer, birth defects or other reproductive harm.*

STORAGE

Pumps are shipped dry from the factory. If a pump has been in storage in a humid environment for more than 6 months the crankcase cover should be removed and carefully examined for rust or water collected in the power end. Flush out any evidence of rust or damage that exists, using a light clean oil.

Pumps to be placed in extended storage should be cleaned, repaired as needed, and completely filled to the top with clean oil to prevent rusting. Rotate pump monthly 4-1/2 revolutions. Plug all openings to prevent air entry and oil leakage.

Fluid ends must be completely drained of water and suction and discharge ports blanked off. Store pump in a clean, dry location.

PUMP LOCATION AND PIPING DESIGN

Locate pump and driver in a clean, well drained, ventilated, and brightly illuminated area, with adequate working spaces around the pump to provide ample

access to fluid end, power end, and associated drive elements. Do not expect good maintenance to result if the pump is positioned on muddy terrain, or in a dirty, cramped, dimly lighted area!

The supply tank(s) should be large to allow dissolved air and other gases to escape from the liquid and allow suspended solids to settle out before entering pump. A system employing dams and settling chambers is desirable.

CAUTION: *All pumps should be installed level. For mobile applications the maximum angle of intermittent operation pumps (SC pumps) should be no more than 5 degrees in any one direction.*

Pumps are not designed to withstand piping weight, vibration, and the effects of thermal piping expansion/contraction. Piping loads may be considerable and the weight of all valving, dampeners, filters, and associated forces, moments, and couples must be completely isolated. Use flexible hoses and rigid piping supports to isolate the pump and its driver from these effects.

SUCTION PIPING

No part of the piping system deserves more careful planning than the suction piping system. Suction piping must be **SHORT, DIRECT, and OVERSIZE**. Use one pipe size larger than the pump suction connection. The shorter it is, the better! 1 to 3 feet per second suction velocity is acceptable.

Reference the following table to size a direct suction line from a tank to a pump.

Suction Piping	
4" – 6"	6" – 8"
MA-155M	MA-155-L
MA-155M-HD	SC-230
	RO-261

Use no elbows, tees, or restricted port valves in this line. Do not install orifice plates or positive displacement type fluid meters in the suction line which act as flow restrictors. Avoid the use of suction filters, if possible. Consider filtering the liquid as it enters the supply tank rather than as it leaves it. The use of an eccentric reducer with the flat side up located at the pump suction connection is recommended. The suction line should slightly rise from tank to pump, and loops in which air may collect must be avoided.

The absolute pressure in a suction line may be less than atmospheric pressure and air may be "sucked" into the line unless all flanges and connections are airtight and watertight. If you can see water leaking out of a suction line when the pump is still, that may mean air is being sucked in when the pump is running.

Suction piping should be buried beneath the frost line, or insulated to avoid freezing in the winter. If the

suction line has a block valve at the supply tank, a suitable relief valve is suggested to relieve the suction piping from any possible dangerous overpressure from the discharge piping system.

Suction piping is often large, heavy (especially when filled with liquid), and tends to vibrate. Proper solid supports are recommended. A suction hose located near the pump will isolate these effects, protecting the pump from the forces and moments that piping weight creates.

New suction piping systems should be flushed free of pipe scale, welding slag, and dirt before starting the pump. Hydrostatic testing to detect air leaks is advisable. Proper choice of suction hose construction is essential to avoid collapse of the hose liner.

Install a dry type compound gauge in the suction line near the pumps which should fluctuate evenly. If violently pulsating, this gauge indicates that the pump is not fully primed, or that one or more valves are inoperative.

ACCELERATION HEAD

A characteristic of all reciprocating pumps is the imperative need to consider the effects of acceleration head which is a **SYSTEM**-related phenomenon. Acceleration head may be considered to be the loss of available hydraulic head (energy) in the piping system occurring because the demand by the pump cylinders for liquid is not smooth and even. Because the pump's demand for liquid is cyclical, the velocity of the liquid in the entire suction system is not truly constant but varies in response to the combined demand of the reciprocating plungers. Thus, liquid in the suction system is compelled to be accelerated and decelerated several times during each crankshaft revolution, depending on the number of plungers. Called "acceleration" head, this loss of available hydraulic head is proportional to:

- (a) The speed (RPM) of the crankshaft
- (b) The average liquid velocity in the piping
- (c) The length of the suction piping
- (d) The number of pumping chambers (triplex, etc.)
- (e) The compressibility of the liquid

Thus, for a given pump, acceleration head effects may be reduced by the use of the shortest possible suction line, sized to reduce liquid velocity to a very low speed. This is often more economical than the use of charge pumps or expensive suction stabilizers.

NOTE: Charge pumps should be sized to 150% of rated pump volume. Charge pumps need to be centrifugals, not a positive displacement pump.

A charging pump is usually not a good substitute for a short, direct, oversize suction line, nor is it a substitute

for the computation of available **NPSH**, acceleration head, friction head, vapor pressure and submergence effects duly considered. Required **NPSHR** of Myers Apex Series pumps depends on speed, choice of plunger size and valve spring type. Consult Myers Apex Series Engineering for help with your particular application. A full discussion of suction system losses is given in the Standards of the Hydraulic Institute, 14th Edition.

A common design mistake is the connecting of two (or more) reciprocating pumps to a **COMMON** suction header. This is a profoundly complicated suction system, largely not amenable to mathematical analysis, and is frequently the cause of severe pump pounding, vibration and early valve failures. Each pump should be fed by its own separate, individual piping system, free from the effects of other pump cyclical demands for liquid.

DISCHARGE PIPING

A properly designed discharge piping system usually prevents the need of a pulsation dampener. The most common mistakes made in the design of the discharge piping system are:

1. Pumping directly into a tee or header. A "standing" wave (either audible or subaudible) then often occurs. If flow must enter a header, use a 45° branch lateral (or equivalent) to avoid a reflecting surface from which sound can reflect.
2. Pumping into short radius 90° elbows. Instead, use two 45° elbows spaced 10 or more pipe diameters apart.
3. Pumping into a right angle choke valve.
4. Pumping into too small piping line size. Piping should be sized to keep fluid velocity below 15 feet per second, max.
5. Pumping through an orifice plate, small venturi, or reduced port "regular opening" valve.
6. Pumping through a quick closing valve, which can cause hydraulic shock (water-hammer).

A good discharge piping system includes:

1. A properly sized, correctly set relief valve. Discharge from relief valve returned to tank (not to pump suction).
2. A full opening discharge gate or ball valve. Avoid restricting plug valves, globe valves and angle valves.
3. A pressure gauge with gauge dampener or snubber. Consider a liquid filled gauge. (Scale range to be double the normal pump operating pressure.)

Locate the relief valve and pressure gauge ahead of any block valve and so that the pressure in the pump

is always reflected at the relief valve. The relieving capacity of the relief valve must exceed the capacity of the pump to avoid excessive pressure while relieving.

Use a full size relief line.

To minimize vibration (whether hydraulic or mechanical), discharge lines should be kept short, direct, well supported and solidly anchored. Avoid “dead” ends and abrupt direction changes.

BYPASS PIPING

Some designers ignore this important aspect of proper design of pump piping systems.

A reciprocating pump, especially after maintenance of the valves or plungers, **STARTS WITH ONE OR MORE FLUID CHAMBERS FULL OF AIR**. Pumps operating on propane, butane, or other volatile liquids **START WITH VAPOR IN THE FLUID CHAMBER(S)**.

Positive displacement pumps do not automatically purge themselves of air and gas after shutdown. For example, a quintuplex plunger pump will, after servicing, expel the air in four of the five pump chambers. Thus, the pressure from four of the “active” cylinders will keep shut the discharge valve of the “inactive”, or “air bound,” cylinder. Then, the air or gas in this cylinder will be compressed and expanded by its reciprocating plunger and never leave the chamber. Similar effects occur in duplex and triplex pumps.

To overcome these difficulties, adequate provision for expelling the gas in the “air bound” cylinders must be present. Common practice is to totally relieve the pump of all discharge pressure during the start-up, after servicing.

Consider the operational advantage of a full-sized bypass line (return to tank) which substantially removes discharge pressure from all cylinders during the start. This requires a block valve on the discharge side and a full opening bypass valve on the other side.

For economy, the bypass (to tank) can be combined with the relief valve discharge line. This line must be full-sized, well supported, and sloped downward to avoid freezing in cold weather. (A frozen relief valve line provides **NO** protection to either the pump or operating personnel!)

The ability of a reciprocating pump to be “self-priming” depends on the ratio of the swept (displaced) volume in the cylinder to the unswept (clearance) volume at the end of the stroke. This depends on the design of the fluid end and on the plunger size selected.

Choice of the largest size plunger for a particular fluid end improves this compression ratio and so leads to “self priming”, or easy priming. Choice of the minimum size plunger sometimes leads to

difficulties, especially with pumps that require frequent servicing, or which handle volatile liquids, or which contain substantial amounts of dissolved air or gas. An automatic bypass and purging system for these applications may be merited.

LUBRICATION

Myers Apex Series pumps use S.A.E. 40 wt. nondetergent oil in the crankcase. This oil requires only a nonfoaming additive and should possess good water separation (antiemulsion) characteristics. Such oils are often labeled “industrial” or “turbine” quality lubricants. If these oils are not available, a good quality gear oil or EP oil may be substituted. See lubrication guidelines.

In temperate climates, oil viscosity selected should fall between 70 and 84 seconds Saybolt viscosimeter at 210° F. In arctic service, low pour point oils are needed.

After the first 500 hours of operation in a new pump, drain the oil. Refill with clean, fresh oil. Thereafter, change the oil every 1,500 hours or sooner if it becomes contaminated with water or dirt. Fill to the center of the sight gauge. Recheck after starting, adding oil to center of gauge while running.

The oil capacity is 22 U.S. quarts.

V-BELT DRIVE

A properly designed, well-aligned V-belt will provide years of reliable, economical service if properly tensioned and kept dry, free of oil and ventilated.

Alignment is critical for long life. If the shaft axes are not truly parallel, or if the sheave grooves are not positioned in good alignment, some belts will carry most of the load, resulting in their disproportionate load share and may actually twist or turn over in the groove. Use a straight edge across the rim of the sheaves to detect and correct for misalignment.

After about one week of operation, new V-belts will have stretched somewhat. The motor must be moved on its slide base to re-establish proper belt tensioning.

Insufficient tension results in slippage, burning, squealing (especially during starting) and shortened belt life. Overtightening imposes excessive loads on pump and motor bearings and can cause early shaft fatigue failure.

SUGGESTED PIPING SYSTEM FOR PLUNGER PUMPS

NOTES

- 1) CENTERLINE OF PUMP SUCTION (INLET) TO BE SLIGHTLY HIGHER THAN CENTERLINE OF SUCTION (INLET) VALVE, SO ANY AIR IN SUCTION SYSTEM PROMPTLY REACHES THE PUMP AND IS EXPELLED.
- 2) SLOPE BYPASS SO LOW POINT DRAIN WILL FULLY EMPTY RELIEF AND CHOKE VALVES AND ALL LIQUID IN BYPASS CIRCUIT.
- 3) DO NOT LOCATE PIPING OR OTHER EQUIPMENT IN FRONT OF OR ABOVE PUMP LIQUID END, PREVENTING SERVICING.
- 4) LOCATE CHARGING PUMP AT POINT SHOWN IF A CHARGING PUMP IS NECESSARY (AS FOR VOLATILE FLUIDS, FOR EXAMPLE).
- 5) IF DESIRED, A TWO-WAY MOTOR-OPERATED BYPASS VALVE MAY BE USED RATHER THAN A MANUAL TYPE. IT SHOULD BE DESIGNED TO OPEN AUTOMATICALLY WHILE STARTING OR STOPPING.
- 6) FEED LINE AND BYPASS LINE SHOULD FEED LIQUID INTO TANK BELOW MINIMUM LIQUID LEVEL.

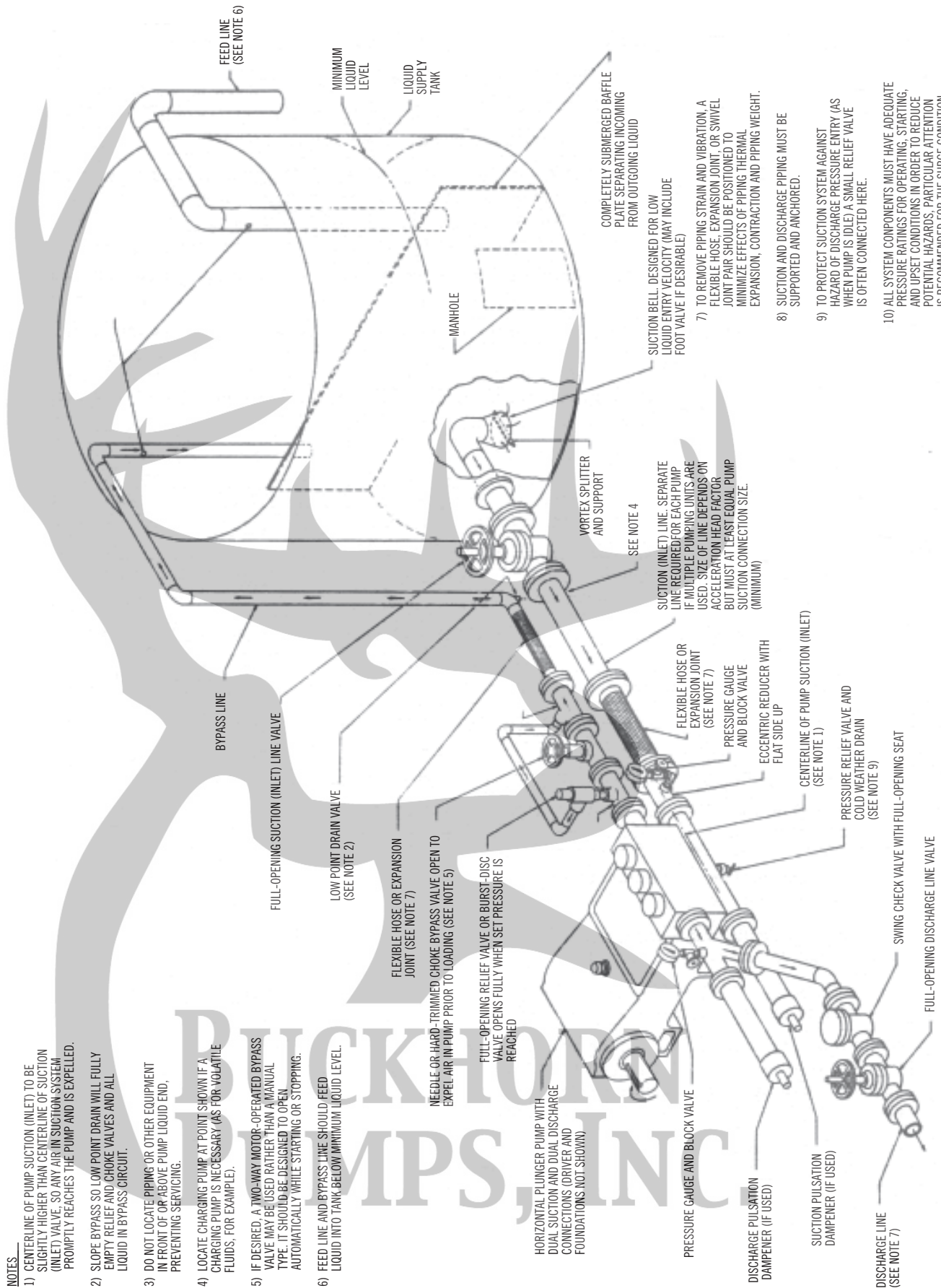

BUCKHORN PUMPS, INC.

Use the following table in adjusting V-belt tension:

Belt Cross-Section	Tension at Mid-Span	
	New Belts	Used Belts
"B"	5 – 6 lbs.	3-1/4 – 5 lbs.
"C"	9-3/4 – 13 lbs.	6-1/2 – 9-3/4 lbs.
"3V"	4 – 10 lbs.	3 – 7-1/2 lbs.
"5V"	17 – 30 lbs.	13 – 23 lbs.

Applying the above forces with a small spring scale, adjust motor position to provide the following deflection at mid-span:

Approx. Center Distance (Span), inches	Deflection, inches
16	1/4
22	3/8
28	7/16
32	1/2
40	5/8
48	3/4
60	15/16

Belts must be matched in pitch length. If one or two belts are slack, when the others are correctly tensioned, investigate for possible reasons. Correct any misalignment or lack of matching so each belt will transmit its load share.

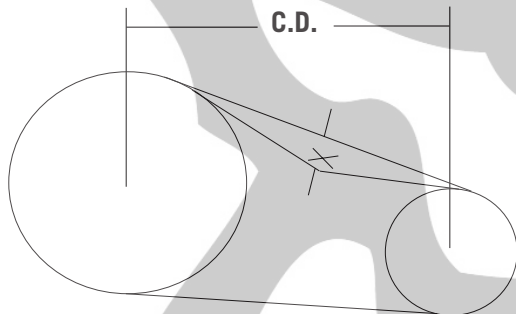

Sheaves must be balanced to prevent abnormal vibration. Balancing weights must **NOT** be removed. Type "QD" sheaves must be evenly tightened on their tapered hubs to avoid rim wobble and severe lateral vibration. V-belts that snap and jerk will produce abnormal vibration and loads on both pump and motor or engine.

Run the pump several minutes at full load with belt guard removed, observing for uneven motion on the belt slack side, especially.

When an old V-belt drive becomes unserviceable, replace **ALL** belts, not just the broken or cracked belts. Do not operate belts on sheaves having worn, rusted, greasy or broken grooves. Shut off power to driver before servicing drive or pump.

WARNING: Do not operate without appropriate guards in place.

DIRECTION OF ROTATION

Before placing pump in operation, check that crankshaft rotation agrees with the arrows cast on top of the power frame by briefly jogging the electric motor. Crankshaft rotation must be clockwise as viewed from the right side of pump.

If pump is gear driven, remember that the pinion shaft turns opposite the crankshaft, if using a single-reduction geared drive or in the same direction as the crankshaft when using a planetary gear.

AUTOMATIC (SAFETY) SHUTDOWNS

Carefully check all electric shutdown devices present, such as crankcase oil level, discharge pressure, vibration, lubricator oil level, motor thermostat, etc.

CRANKSHAFT ASSEMBLY

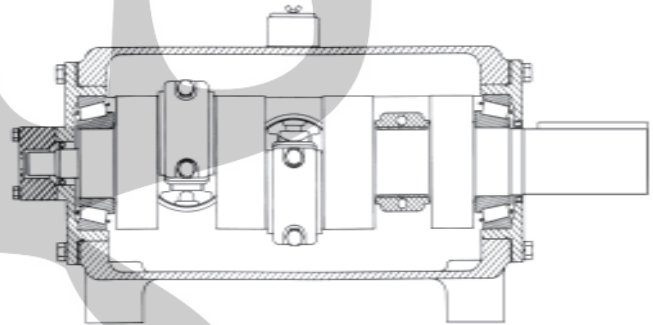

GENERAL

Myers Apex Series crankshaft suspension uses two single-row tapered bearings, which are shim adjusted to provide the correct running clearance.

Thorough cleaning of all components prior to assembly is essential.

Power frame, shaft, bearings and retainer **MUST** be scrupulously scrubbed with clean solvent (such as kerosene) before starting. Remove any oil, dirt, rust and foreign matter which might prevent the correct fit up.

Crankshaft journals are critical. Remove all burrs, rust spots, and nicks, paying special attention to the ground areas on which bearings and oil seals operate.

Connecting rods and crossheads must be previously installed into CA-125M pumps before the crankshaft assembly.

TAPERED ROLLER BEARINGS

Shaft and frame tolerances provide a tight (shrink) fit on the shaft and in the carrier. The best way to install the cone assembly (consists of the inner race, cage and rollers) on the shaft is to heat the cone assembly

in an electric oven for 30 minutes at 300 to 400°F. No more! (**DO NOT** heat bearings with an acetylene torch. This ruins the bearings!) Using clean, insulated gloves, remove the hot cone assembly from the oven, promptly dropping it on to the shaft.

The cone assembly **MUST** contact the seat thrust face (not be cocked), and the large end of the rollers **MUST** be down. Do not hammer on the bearing. The soft steel cage is easily distorted, ruining its function as a roller separator and guide against skewing. If the cone does not contact its thrust face properly, it must be pressed into place using a specially machined sleeve (which does not touch the soft steel cage). A hydraulic press is recommended if this difficulty arises.

CUP INSTALLATION

Tapered roller bearing cup (outer races) is a press-fit in the bearing carrier, using a hydraulic press. Cup must be pressed into a clean carrier until the race solidly abuts its shoulder (must not be cocked).

The tool or plate used for this must contact only the outer end face – not on the taper.

selection. Bump the shaft in one direction and zero the dial indicator. Bump the shaft the opposite way. If shimming is correct, the shaft will move laterally from .005" to .015".

About equal shim set (totals) are required under each carrier flange.

The recommended tightening torque for bearing retainer 3/4"-10UNC cap screws is 211 to 257 ft. lb.

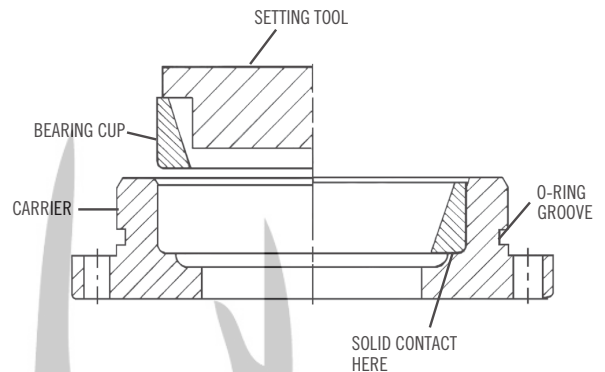

INSTALLING CRANKSHAFT

SHIM ADJUSTMENT OF TAPERED ROLLER BEARINGS

To provide for crankshaft thermal expansion, sufficient shims (located beneath bearing retainer flange) must be installed to provide .005" to .015" lateral end play, when shaft is cold.

A feeler gauge and a 1" micrometer caliper are required. Install a trail shim set on one side of the pump. Tighten the flange bolts on this side only.

CAUTION: Lubricate the frame bores and the O-ring seals located in each carrier to prevent damage during entry. Oil the bearings.

Omitting the shim set on the opposite side, draw up the carrier, evenly tightening its cap screws. Rotate the crankshaft slowly by hand, seating all rollers into running position.

Measure the gap existing between the frame face and carrier flange. The correct thickness of the shim set to be installed on this side equals the measure gap **Plus** about .010". (No preload)

After installing above shim set, a dial indicator may be used against the end of the shaft to confirm the shim

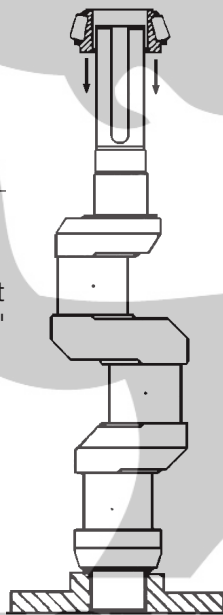

INSTALLATION OF CRANKSHAFT OIL SEAL

Insert oil seal over the end of crankshaft and position it into the oil seal bore in the power frame of bearing retainer. Using a rubber mallet, tap it into the bore until the face of the seal is flush with the power frame or bearing retainer.

DISASSEMBLY

After removing the connecting rod cap and cap bolts (note identifying marks on each cap so each may be later correctly reassembled onto its own rod) remove a bearing carrier from the frame. Two jack out tapped holes are provided in the flange of the carrier for this purpose. Support the shaft during removal to avoid damage.

The crankshaft may now be extracted, once all connecting rods are moved clear. Examine the crankpin surfaces for wear or corrosive pitting. The correct diameters of these journals are:

Crankpin Diameter..... 4.5000/4.4990"

If worn more than .010" undersize, crankshaft should be replaced, or an attempt to salvage it may be made at a shop well equipped to grind the crankpins which must be fully round, chrome plated, and finish ground to the above sizes. (Myers Apex Series does not perform this function.)

Crankshaft tapered roller bearings should be carefully examined for pitting, scoring or corrosion, and replaced as required. The cone and roller assembly is most easily removed by first cutting away the cage using an acetylene cutting torch. Then heat the cone (inner

race) with the shaft held vertically so cone will drop off due to its own weight. Avoid excessive heat on the crankshaft which tends to distort its geometry.

Cups (outer races) of tapered roller bearings may be extracted from bearing carrier using a conventional bearing puller tool of the automotive type (widely available). Do not attempt to use heat on a bearing carrier as this will result in severe distortion (out-of-round). Replace the bearing carrier, if broken or out-of-round.

CONNECTING ROD, CROSSHEAD, EXTENSION ROD, CROSSHEAD PIN AND WIPER BOX ASSEMBLY/ DISASSEMBLY

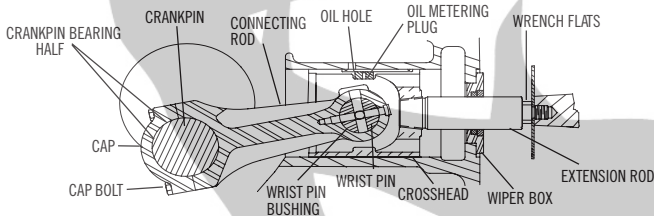

GENERAL

Myers Aplex Series connecting rod assemblies employ precision automotive type steel backed, babbitt-lined crankpin bearing halves which require no shims for clearance adjustment. This pump employs full circle (piston type) crossheads and hardened stainless steel extension rods, which are field replaceable.

Extension rods are provided with wrenching flats to permit tightening of the tapered thread into the crosshead, establishing accurate alignment while affording easy field installation.

Before beginning the assembly all parts must be scrupulously cleaned, removing all oil, dirt, rust, and foreign matter which prevent proper fitting, or which might tend to score the rubbing surfaces. Clean and examine the power frame bores for scoring and abnormal wear, especially wear of the lower crosshead guide way. Hone smooth, if rough.

Measure the bores of the frame using inside micrometers to determine abnormal frame wear if any.

Crosshead O.D.: 6.740/6.737
New Frame Bores: 6.749/6.752

Frame bores that have become worn more than .015" must be sleeved with a cast iron liner to re-establish correct geometry and alignment. Contact Myers Aplex Series concerning the repair of badly worn frame bores.

Smooth any rough corners and edges on the crosshead skirts, using fine emery cloth. Examine and clean the female tapered threads and wrist pin holes.

INSTALLING WRIST PIN BUSHINGS

The wrist pin bushing is precision machined bearing bronze which is press fitted into the eye of the connecting rod.

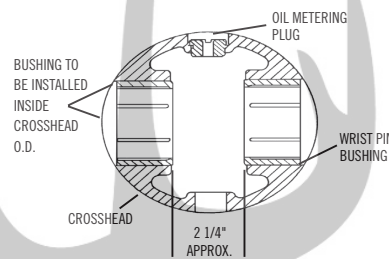

Bushing O.D.: 3.2525/3.2515
Connecting Rod Eye: 3.250/3.251

**MA-155 requires two bushings per crosshead.*

After applying oil to the bushing O.D., use a hydraulic press to force it home. Repeat this procedure for the second bushing. When a bronze bushing is pressed into place, the I.D. (bore) of the bushing is reduced somewhat, owing to the extent of press fit. Therefore, a clean, new wrist pin should be inserted into the bushing bore to establish that running clearance has been obtained. The running clearance between the wrist pin and installed bushing is:

New Pin O.D.: 2.6875/2.6860
Installed Bushing Bore: 2.6895/2.6905

Oil Clearance0020/.0045"

Replacement bushings are furnished prebored by Myers Aplex Series which usually eliminates the need to ream the installed bushing bore. However, due to slight variations in finishes and tolerances it sometimes happens that more than predicted contraction of the I.D. occurs. This occurrence results in a slight interference which may be eliminated by lightly honing the bore of the bronze. (**NOT** by reducing the pin size!) An automotive engine repair shop usually is equipped with power honing machines capable of smoothly finishing the bushing bore. Bore of bushing must be round and free of taper.

BOLTING THE WRIST PIN

After pressing in the two bronze bushings, the wrist pin must be bolted to the connecting rod. Place the connecting rod inside the crosshead and slide the wrist pin through the crosshead and connecting rod.

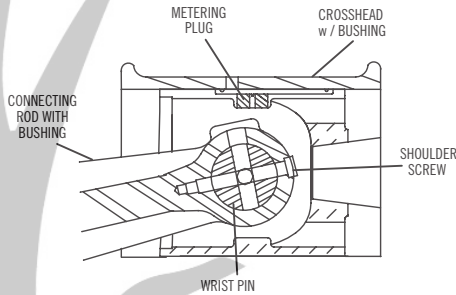

The hole in the wrist pin should line up with the hole in the connecting rod. Install the shoulder bolt through the wrist pin and thread into connecting rod.

Torque to 25 ft. lb.

After installing the pin, carefully check the crosshead O.D. to see if it is out-of-round. If so, a smart blow with a rubber mallet will restore the crosshead O.D. into its original roundness.

ORDER OF ASSEMBLY

The connecting rod/crosshead assembly is installed **BEFORE** the crankshaft is installed, because the wiper box wall bore is smaller than the crosshead O.D.

This is most easily done by setting the power frame vertically and dropping each crosshead assembly into its frame bore.

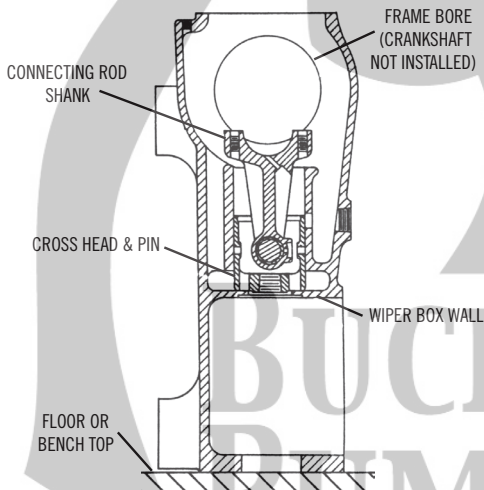

NOTE: The connecting rod must clear the frame bore circle in order to introduce the crankshaft in these models.

New Crankpin O.D.: 4.5/4.499
New Connecting Rod Bore: 4.851/4.853

Crankpins that are worn out-of-round, tapered, or badly scored should either be discarded or perhaps salvaged by grinding undersize, hard chrome-plated, and finish ground to above diameter.

(Myers Apex Series does not offer this service.)

Connecting rod/cap bore must be perfectly round and within above sizes and free of taper. Discard, if elliptical or tapered as the result of abnormal heating. Each cap and rod is match-marked for correct identification. Take care that each cap is reinstalled properly with its companion rod. Bearing halves are identical and are prevented from rotating by tongues which fit into slots in the cap.

Check that all oil holes are clean and fully open. **GRIT** is the greatest enemy of bearings, however precisely manufactured. Hence, all surfaces must be perfectly clean and lightly oiled prior to assembly. Remove any burrs or sharp corners which prevent the perfect fitting of these precision bearings. Using a torque wrench, tighten cap bolts as follows:

Thread Size: 5/8" – 18UNC
Tightening Torque: 125-135 Ft. Lb.

Specified torque, applied to clean, well oiled threads and bearing faces, will create tensile stresses in the cap bolts from 90,000 to 110,000 psi, approx. and will provide correct initial tension. Myers Apex Series pumps use high strength cap bolts suitable for these initial loadings, maintained by safety wire to keep the required tightness.

After all rods and caps are secured, slowly turn the crankshaft to be sure no bearings are in a bind.

Using a flashlight, examine the location of each connecting rod (eye end) within its crosshead. Rods must not touch any crosshead boss or skirt.

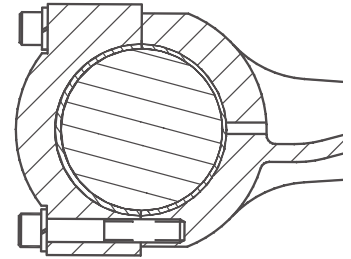

OIL SCOOP

This pump is provided with a bronze oil scoop which shears off oil adhering to the crankshaft cheek, depositing oil on the deck above the crossheads, assuring adequate lubrication even at low pump speeds.

The scoop is adjustable in position, and is set lightly in contact with the crankshaft. Secure it, tightening the self-locking nuts securely. Note that fiber washers are employed underneath the bolt heads, preventing oil seepage to the outside.

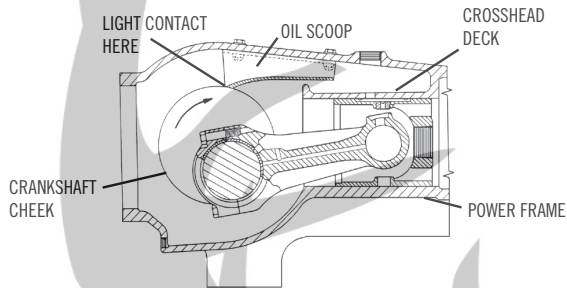

WIPER BOX ASSEMBLY

GENERAL

Extension rod wiper boxes (sometimes referred to as the diaphragm stuffing box or stripper housing assembly) serve two important functions: retention of crankcase oil in the power end and exclusion of dirt and water.

Myers Aplex Series has developed a unique sealing set which operates on a hardened and ground stainless steel extension rod (often called “pony” rod), and a steel baffle disc affording protection against leaking plunger packing. The seals require no adjustment, only correct and careful assembly.

“POLY PAK” SEAL

This seal keeps oil from leaking out of the power frame. Developed by the Parker Seal Group, this patented rod seal employs a soft nitrile rubber O-ring to energize a special hard polyurethane Molythane® shell by forcing the inner lip against the rod and the outer lip against the housing bore, as shown.

The Poly Pak seal is inserted into its counter bore with its lips directed toward the oil in the crankcase. (Will **NOT** work if installed backward!)

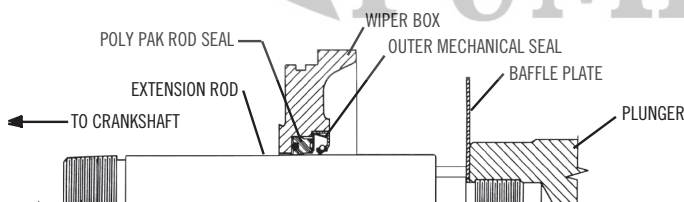

MECHANICAL OIL SEAL

The oil seal is to keep contamination out of the power frame. With the box positioned in a hydraulic press, install the backup seal against the Poly Pak seal, with the lips of both seals facing downward.

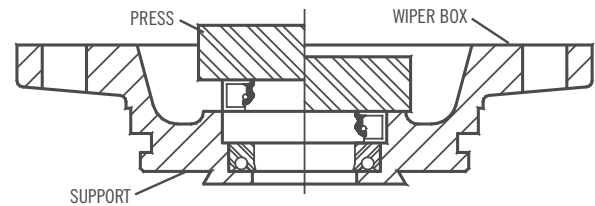

The mechanical seal contains a garter spring. Check to see that this spring is still properly located and in its position. The mechanical seal has a metal case which serves to force the Poly Pak seal into its cavity, energizing its lips. Apply oil lightly to the bore of the box before pressing each seal into its counterbore.

INSERTING THE EXTENSION ROD

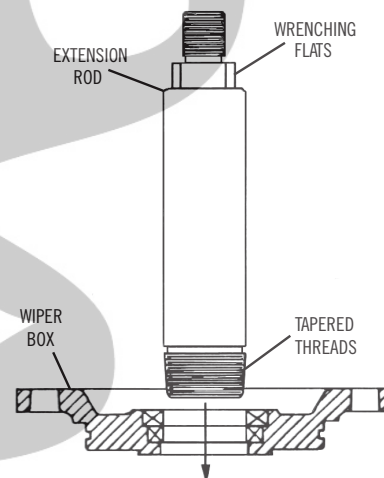

Insert the extension rod through the wiper seals with the tapered thread and entering **FIRST**. Care should be used in moving the extension rod through the seals with wrenching flats entering first. **Do not force!** The sharp corners on the wrenching flats may damage the seal lips! (Resulting in oil leakage.)

With extension rod inserted through the wiper box seals, thread the tapered threads (must be clean!) into the tapered crosshead female threads. Firmly tighten, applying torque to the wrenching flats only. Never damage the extension rod ground surfaces!

Then fasten the wiper box to the power frame by tightening the cap screws. Oil leakage between frame face and wiper box is prevented by use of a gasket beneath the box flange.

STUFFING BOX, PACKING AND PLUNGER ASSEMBLIES

GENERAL

Myers Apex Series pumps all feature field removable and replaceable stuffing boxes with plungers separable from the extension rods.

If desired, the boxes, plungers, and packing units may be installed (or removed) as a unit assembly, permitting service outside the pump. All boxes are retained by four (4) studs and nuts, and are centered in the frame bore, ensuring correct alignment.

The plungers may also be removed separately (without box removal) to facilitate repacking. With this option, the necessary space required to remove plunger, it is first necessary to remove the extension rod.

SPRING LOADED PACKING

Compression Packing

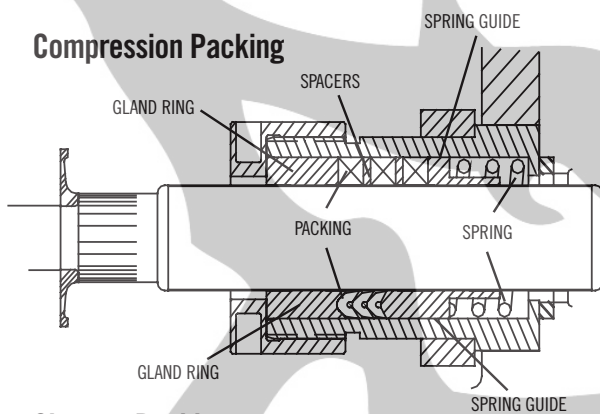

Chevron Packing

Note that the gland is screwed tightly onto the box and contacts its face. The spring is providing all of the initial compression and adjustment. No adjustment is provided by the gland.

Since the force exerted by the spring is contingent on the space provided for it, the correct lengths of all rings are essential for good tensioning.

Spring:

A stiff Inconel® spring, which closely fits the bore of the stuffing box, is used in this assembly. This spring is compressed in a vise to the operating length required plus 0.25" and tied with waxed nylon spot tie cord. The cord is looped over the ends of the spring through the coils and tied to maintain the length mentioned above. Each spring is assembled into the stuffing box. Note that the spring does not contact the plunger.

Spring-Guide Ring:

Plungers are heavy and the importance of a well-fitted guide ring that carries this weight is often overlooked.

Discard any guide ring that becomes worn or scored, as it will then not serve its purpose. It should fit snugly in the box. Apply oil generously to this ring.

Spring Loaded Packing:

Three (3) rings of chevron or compression packing are installed next. For compression packing, install them with the skive intersections 180° apart to discourage leaking.

Gland Ring:

This ring also fits the plunger and helps support the plunger weight. Discard it if bore is worn, rough or out-of-round. Lightly oil the ring before insertion. The gland ring fits all packing.

J-STYLE STUFFING BOX & PLUNGER ASSEMBLY (STYLES 838 & 858)

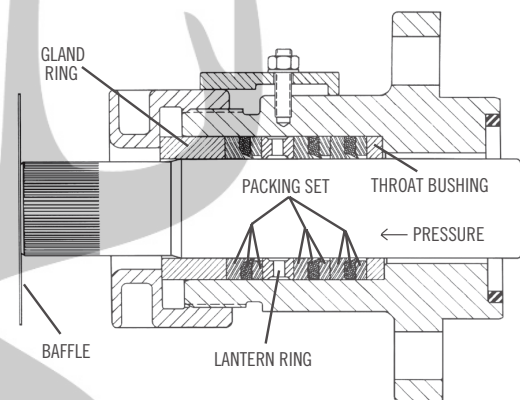

Above depicts Styles 838 and 858 packing correctly installed with all packing lips facing **TOWARD** the fluid pressure. Note that two (2) units of Styles 838 and 858 packing are positioned ahead of the lantern ring, and one (1) unit is positioned behind it. Thus lubricant entering the lantern ring is forced toward the pressure.

Throat Bushing:

Plungers are heavy and the importance of a well fitted throat bushing that carries this weight is often overlooked. Discard any throat bushing that becomes worn or scored, as it will not then serve its purpose. It should fit snugly in the bottom of the box. Apply oil generously to this ring.

Styles 838 and 858 Packing:

Developed by Utex Industries, Inc., Styles 838 and 858 are a **NON**-adjustable type packing which depends solely on hydraulic pressure to energize the sealing lips. (Gland-tightening forces do **NOT** energize the lips.) Tightening and hydraulic end thrust loads are transmitted entirely through the center support portions of each ring.

The flattened portions of the rings are large enough to withstand overtightening. Do **NOT** attempt to adjust this type packing. It should be kept thoroughly

tightened at all times. (Running it loose will ultimately ruin the bore of the box.)

Running it loose will **NOT** usually cause it to drip at all, but it can ruin the box in time.

Lightly oil each ring and the box bore and then lightly tap in each ring separately with the rings facing correctly. This is most easily done before installing the plunger.

Lantern rings are provided with O.D. and I.D. reliefs and two (or more) oil holes to allow lubricant to reach the plunger. After the last unit of Styles 838 and 858 packing is in place, generously oil the lips of all seal rings to ease plunger entry.

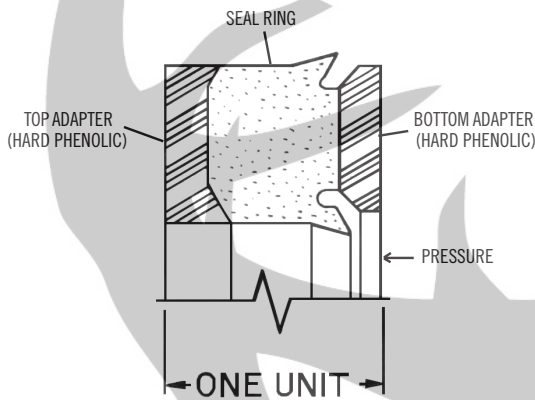

INSERTING THE PLUNGER

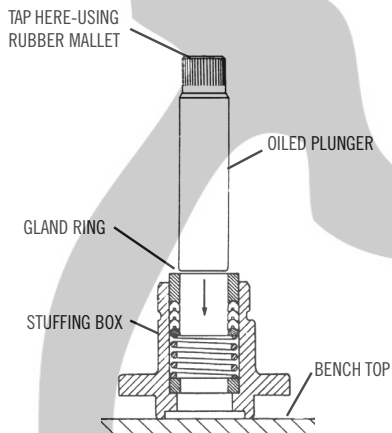

Apply oil liberally to plunger O.D. and lightly tap it through the packing. When introducing the plunger through the MA-155M stuffing boxes, also apply oil liberally to the O.D. of each extension rod to allow easy passage through the wiper box seals.

A soft rubber mallet is recommended to avoid any damage to the plunger face or its threads. Remember: The fragile nature of packing rings and plunger surfaces deserves your respect and avoidance of careless damage to these key elements!

INSTALLING THE GLAND

Considerable downward pressure on the gland is required to compress the spring, to move the packing into location, and to start the threads of the box.

Once the gland threads are started, screw it down completely until it makes up tightly against the face of the box, for spring loaded packing. For Hi/Lo, J-Style or Gland adjusted packing, tighten the gland until it is seated firmly against the packing.

INSTALLING THE STUFFING BOX

Myers Apex Series stuffing boxes derive their alignment from the bores of the power frame and the faces of the fluid end. So these surfaces **MUST** be cleaned of rust, scale, and dirt before assembly is begun. Wash all contacting surfaces with clean solvent and dry with a **CLEAN** shop towel.

A nitrile rubber seal is used to seal between the face of the fluid end (must be flat, clean and smooth) and the face of the box. Replace if damaged.

All stuffing boxes are retained by four large studs and nuts which extend through the power end, serving to clamp the box and the power frame tightly against the fluid end face. These four stud nuts must be **EVENLY** tightened.

Using a socket, socket extension, and torque wrench, tighten clean, well-oiled threads and nut faces.

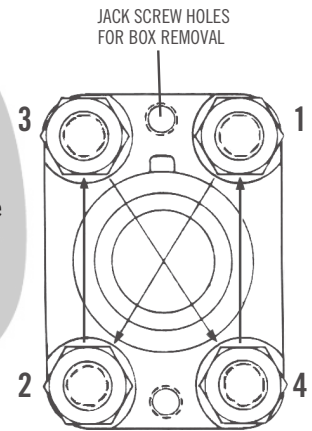

Stud Threads	
1-1/4" – 8UN at 900–950 Ft. Lb.	1" – 8UN at 350–400 Ft. Lb.
SC-230	RO-261
MA-155L	
MA-155M	
MA-155M-HD	

CONNECTING THE PLUNGER

Install the metal baffle plate on the extension rod and roll the pump slowly until the extension rod male threads just touch the mating plunger female threads.

Applying a pipe wrench to plunger knurled area, thoroughly tighten the connection. Do **NOT** use a "cheater" when connecting plunger to extension rod. (Serves no useful purpose, and may damage the connection!)

PACKING

Packing life for aramid fiber packing may be improved in some applications by regular, systematic lubrication. An optional force feed lubricator assembly is often recommended especially for pumps on continuous duty. This provides regular, controlled supply of lubricant lowering friction and heat.

Additionally, the regular application of the correct lubricant aids dissolving of salt and gyp tending to build up on the plungers in produced water applications. For this service, Rock Drill Lubricant is a popular and effective packing lubricant.

Plungers in CO₂, ethane, or other very cold liquid services may use brake fluid. This fluid does not congeal into a solid which cannot enter the packing. Consider the use of an air-sealed cradle into which dry (instrument) air may be directed, excluding the moisture which causes plunger icing especially in very humid conditions.

Packing lubricant for pumps on light hydrocarbons, hot water, lean oil, naphtha, or gasoline often requires experimentation.

A good start is to use steam cylinder oil. Castor oil is sometimes successful as a packing lubrication for liquid propane and butane services, at ambient temperature.

In pumps placed in arctic service, a special low pour point oil is indicated.

Packing lubrication is not permitted on some services, such as amine, food stuffs, etc., and other packing styles and materials may be required.

PLUNGERS

Myers Apex Series offers its own unique product: the Myers Apex Series Rokide® plunger. This premier quality plunger consists of a chromium-oxide deposition on a solid stainless steel body.

Ordinary handling will not damage this fine product. Avoid striking the coated surface (black) during installation. Apply light forces only on the ends of the plunger. Do not hammer or pry.

All threads on Myers Apex Series plungers must be **CLEAN** and oiled before assembly. Stainless steel (although very corrosion resistant) has a tendency to gall and seize. To avoid this, an anti-seizing lubricant is well worth its use. Apply oil to the threads and the rubbing surface.

Myers Apex Series can supply solid ceramic plungers on order. This plunger is very fragile, vulnerable to thermal and mechanical shock, and must be handled with the greatest care. Use only a rubber mallet to

insert it into the packing. Other plunger types are available upon request.

DISC VALVE SYSTEMS AND ABRASION RESISTANT VALVE CONSTRUCTION

GENERAL

Myers Apex Series has developed a unique setting/puller system permitting quick, easy and safe methods of installing and removing tapered seat valves.

The system allows servicing without distortion of the seat, with minimum effort and **NO** damage to fluid end tapers or seat.

Tapered seats notoriously drive solidly down into mating deck tapers, so firmly that extraction heretofore has always posed severe problems. Old style valves may be pulled only with the greatest effort, using "J" puller heads (prone to failure), CO₂ – dry ice, and other improvisations.

DISC VALVE AND ABRASION RESISTANT VALVE CONSTRUCTION

TYPICAL DISC VALVE

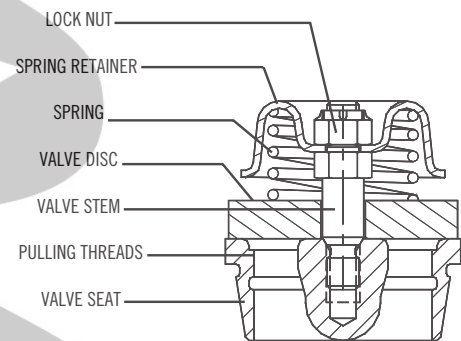

TYPICAL ABRASION RESISTANT VALVE

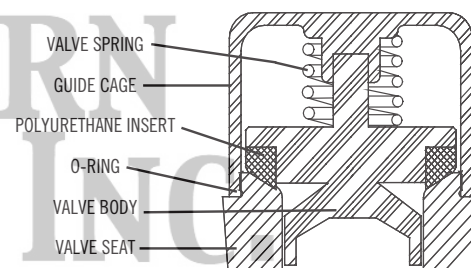

The Myers Apex Series valve is a precision made subassembly using threads cut into the rim of seat for use with Myers Apex Series setting/pulling tool. These threads do **NOT** deteriorate as proved by field

experience. By locating these on the rim, setting/pulling forces are now applied only to the rim of the seat, never to the webs (or “spokes”), or to the center section. Distortion of the seat is eliminated.

Access to these seat threads is provided by the removal of the valve cage on abrasion resistant valve or the spring retainer on disc valves which is screwed onto the seat. An anti-seizing lubricant applied to all threads is good insurance against future difficulty.

SETTING THE VALVE SEAT

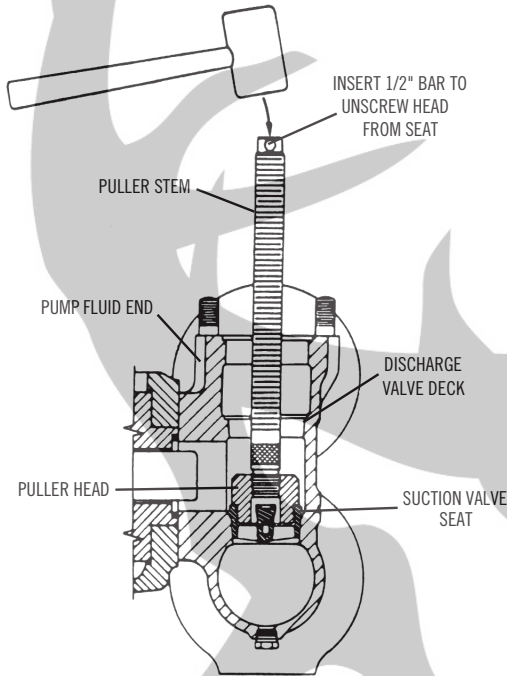

Effective pressure-sealing between tapered (male) seat and tapered (female) fluid end deck is possible **ONLY** if the tapers are absolutely clean and dry just prior to installation. Thoroughly clean surfaces using a clean solvent. Dry with a **CLEAN** shop towel.

Examine the cleaned fluid end deck tapers, using a flashlight, and remove all deposits of gyp, salt, or other incrustation. Using emery cloth, lightly rub out any minor imperfections found in the deck taper.

The puller stem and puller head are provided with tapered (locking) threads. Screw them together using two pipe wrenches applied to the knurled areas provided. Then screw the valve seat onto the puller head by hand until it shoulders against the puller shoulder. Do not tighten.

Lower the seat and puller assembly into the fluid end, squarely setting the seat into the deck. Then pound the top of the stem with a 6 pound hammer.

Unscrew the head and stem from the seat using a 1/2" bar (or screwdriver) into the hole provided at the top end of the stem.

INSTALLING O-RINGS, ABRASION RESISTANT SPRING AND CAGE

Install nitrile O-ring over the threaded section of the seat and position it at the bottom of the threads. Install the polyurethane insert into the valve. The insert may be heated in hot water to make it flexible enough to stretch over the valve. Position the valve into the seat. Install the valve spring. Apply anti-seizing lubricant to the threads of the valve cage and screw the cage on to the threaded valve seat with cage setting tool.

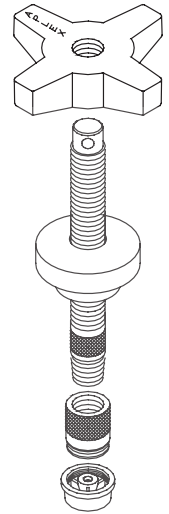

INSTALLING DISC, SPRING, DISC VALVES AND STEM

Myers Apex Series offers discs of Delrin® acetal resin, of 17-4PH S.S. hardened and ground, and of titanium alloy.

Position the disc and Inconel® spring on the seat, aligning the hole in the disc with the stem threads in the seat center.

The stem, spring retainer, and locknut are shipped from Myers Apex Series already assembled and tightened with a torque wrench with Loctite® sealant added to the top stem threads only.

Stem Threads	Tightening Torque
1/2"-13UNC	65-75 ft. lb.

Use an anti-seizing lubricant in these threads. This is very necessary when seats and stems of Type 316 stainless steel are selected (optional) to prevent galling. CLEANLINESS of threads and other contacting surfaces is of paramount importance in the assembly of all valve elements.

VALVE SPRING OPTIONS

All Myers Apex Series valve springs are made of Inconel® material, precisely designed and fabricated. Unless otherwise specified, the standard spring is furnished. It provides excellent results in the great majority of applications.

Pumps employed in marginally available NPSH conditions may require a softer spring, to reduce the required NPSH. For these special conditions, Myers Apex Series can supply light valve springs which exert lower pressure on the valve disc. The use of light valve springs may be limited by the choice of plunger size and/or limited by the chosen speed of the pump. Light valve springs may be impractical for pump models fitted with their maximum plunger size, or which

operate near top speed rating as disc bouncing and erratic seating may occur.

VALVE DISC OPTIONS

Myers Apex Series acetal resin discs made of DuPont Delrin® are machined flat and smooth to produce perfect sealing on the lapped-flat face of the seat. Used successfully in thousands of applications, these discs are light, slightly flexible under load, and seal well, even at high pump speeds, providing smooth pump action.

Acetal resins are very resistant to most corrodents, but are not usually suitable where fluid temperatures are above 120 degrees. Nor do they afford long life at extreme pressures. Pressure limitations depend on valve size. But continuous valve operation at pressures above 2,500 psi usually indicates the need of metal valve discs.

For higher temperatures or pressures, Myers Apex Series offers lapped flat, hardened Type 17-4PH stainless discs, or titanium alloy discs. These metal discs are less tolerant of any fine grit in the liquid and are noisier than the acetal resin disc.

PULLING THE VALVE SEAT

First drain the fluid end entirely. For abrasion resistant valves, use the cage wrench to unscrew the cage from the seat. For disc valves unscrew the stem from the seat. Remove the cage, spring and valve from the fluid end. Attach the Myers Apex Series puller head to the puller stem, tighten their tapered threads with a pipe wrench applied to the knurled areas of the puller stem and head. Lower the stem and head into the fluid end and engage the threads of the head onto the seat threads.

Using a 1/2" bar (or screwdriver), rotate the head clockwise and thread it fully onto the seat. But do **NOT** tighten.

Slide the bridge over the stem. Clean and oil the stem threads. Oil the face of the wing nut. Thread wing nut down onto the stem, seating it on the bridge top firmly. Extract the seat from the pump by striking the wing nut with a heavy hammer. A hydraulic ram may also be used. Stand clear of the pump when applying heavy tonnage, as the entire assembly will jump violently upward when the pulling energy is suddenly released!

The Myers Apex Series puller/setting tool and gauge tool are custom designed and built for each specific Myers Apex Series pump model. The same puller head is used on both suction and discharge seats. The bridge is made to fit each model, and its proper use will not damage the valve cover gasket machined counterbore on the top of the fluid end.

SALVAGE OF WORN SEATS

Rough valve seat faces may often be renewed by lapping or grinding, if not deeply fluid-cut.

Perfect flatness is required. A surface grind, followed by lapping on a lapping plate, provides excellent smoothness and the flatness needed for good sealing and smooth running. Metal valve discs may sometimes be salvaged by grinding or lapping, if not deeply cut or cracked.

Delrin® discs are relatively inexpensive and salvage is seldom worthwhile. Replace the stem, if severely worn. Inconel® valve springs rarely require replacement.

OTHER PUMP BRANDS

Myers Apex Series Industries can provide its unique (patented) valve to fit nearly all brands and models of multiplex pumps. An Myers Apex Series seat setting/puller tool is available, too.

TROUBLE LOCATION AND REMEDY

Trouble	Possible Cause	Remedy
Pump fails to deliver required capacity.	Speed incorrect. Belts slipping.	Change drive ratio or tighten belts (if loose). Correct motor speed.
	Air leaking into pump.	Seal with compounds.
	Liquid cylinder valves, seats or plungers worn.	Reface or lap valves and seats; replace packing or plungers.
	Insufficient NPSHA.	Increase suction pressure.
	Pump not filling.	Prime pump.
	Makeup in suction tank less than displacement of pump.	Increase makeup flow. Reduce pump speed.
	Vortex in supply tank.	Increased liquid level in supply tank. Install vortex breaker.
	One or more cylinders not pumping.	Prime all cylinders. Allow pump to operate at low pressure through bypass valve to eliminate vapor.
	Suction lift too great.	Decrease lift. Raise tank level.
	Broken valve springs.	Replace.
	Stuck foot valve.	Clean.
	Pump valve stuck open.	Remove debris beneath valve.
	Clogged suction strainer.	Clean or remove.
	Relief, bypass, pressure valves leaking.	Repair.
Suction and/or discharge piping vibrates or pounds.	Piping too small and/or too long.	Increase size and decrease length. Use booster pump. Use suction and/or discharge pulsation dampeners.
	Worn valves or seats.	Replace or reface.
	Piping inadequately supported.	Improve support at proper locations.
Pump vibrates or pounds.	Gas in liquid.	Submerge return, supply or makeup lines in suction supply tank. If operating under a suction lift, check joints for air leaks.
	Pump valve stuck open.	Remove debris beneath valve.
	Pump not filling.	Increase suction pressure.
	One or more cylinders not pumping.	Prime all cylinders. Allow pump to operate a low pressure through bypass valve to eliminate vapor.
	Excessive pump speed.	Reduce. Check drive ratio.
	Worn valves or seats.	Replace or reface.
	Broken valve spring.	Replace.
	Loose plunger.	Tighten.
	Loose or worn bearings.	Adjust or replace.
	Worn crossheads or guides.	Replace.
	Loose crosshead pin. Loose connecting rod cap bolts.	Adjust or replace.
	Pump running backward.	Correct rotation.

TROUBLE LOCATION AND REMEDY

Trouble	Possible Cause	Remedy
Consistent knock.	Water in power end, crankcase.	Drain. Refill with clean oil.
	Worn or noisy gear.	Replace.
	Worn or loose main bearing, crank pin bearing, wrist pin bushing, plunger, valve seat, low oil level. NOTE: High speed power pumps are not quiet. Checking is necessary only when the sound is erratic.	Adjust or replace. Add oil to proper level.
Packing failure (excessive).	Improper installation.	Install per instructions.
	Improper or inadequate lubrication.	Lubricate per instructions.
	Improper packing selection.	Change to correct packing.
	Scored plungers.	Replace.
	Worn or oversized stuffing box bushings.	Repair or replace. Check bore and outside diameter of bushings frequently. (Many times plungers are replaced and bushings ignored.)
	Plunger misalignment.	Realign. Plungers must operate concentrically in stuffing box.
Wear of liquid end parts.	Abrasive or corrosive action of liquid.	Check valves and seats frequently at start-up to determine schedule for replacing, etc. Eliminate sand, abrasive, air entering pump.
	Incorrect material.	Install correct materials.
Liquid end cylinder failure.	Air entering suction system.	Eliminate air. NOTE: Pitting often leads to hairline cracks which ends in cylinder failure.
Wear of power end parts (excessive).	Poor lubrication.	Replace oil as recommended in instructions. Keep oil clean and at correct temperature. Be sure oil is reaching all bearings.
	Overloading.	Modify pump or system to eliminate overload.
	Liquid in power end.	Drain power end. Eliminate cause or source of liquid entering power end. Relubricate.

BUCKHORN
PUMPS, INC.

TROUBLE LOCATION AND REMEDY

Trouble	Possible Cause	Remedy
Excessive heat in power end. (Above 180°F)	Pump operating backward.	Correct rotation.
	Insufficient oil in power end.	Fill to proper level.
	Excessive oil in power end.	Drain to proper level.
	Incorrect oil viscosity.	Fill with correct oil.
	Overloading.	Reduce load.
	Tight main bearings.	Correct clearance.
	Drive misaligned.	Realign.
	Belts too tight.	Reduce tension.
	Discharge valve of a cylinder(s) stuck open.	Fix valve(s).
	Insufficient cooling.	Provide adequate cooling for oil or reduce ambient temperature.
Pump speed too low.	Increase speed.	

Power Frame Assembly; Connecting Rod, Crosshead & Extension Rod Assembly

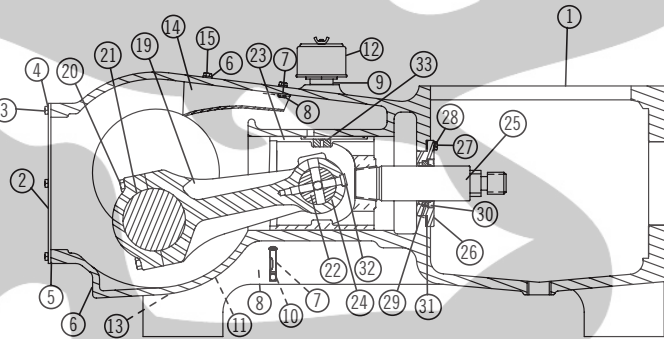

MA-155L, MA-155M, MA-155M-HD, SC-230, RO-261			
Item	Quantity	Description	Part Number
1	1	Power Frame	7201-0048-01K
2	1	Crankcase Cover	7201-0304-00C
3	12	Screw, Cap, Hex Hd., 3/8" NC x 5/8" Lg., SAE Grade 5	100-038058-273
4	12	3/8" Lockwasher, Spring	05454A007
5	1	Gasket, Crankcase Cover	7502-0126-00B
6	1	1/2" Pipe Plug, Hex Head	170-012001-237
7	1	Oil Level Sight Gauge	7602-3000-00A
8	1	Hose, Teflon, 1/4", 304 S.S. Braided	7203-0100-12A
9	4	1/2" Pipe Plug, Socket Head	170-012003-237
10	1	1/4" O.D. Tube x 1/4" N.P.T.M. Bulkhead Fitting	7602-3006-00A
11	1	1/4" O.D. x 90 degree x 1/4" N.P.T.M. Fitting	246-014014-220
12	1	1-1/4" NPTM Crankcase Breather	7602-3001-00A
13	1	1/4" Pipe Plug, Square Head	05022A047
14	1	Oil Scoop	7201-0352-00D
15	4	1/2" NC x 1-3/4" Lg. Hex Hd. Cap Screw	100-012234-273
16	4	1/2" Stat-O-Seal Washer	156-012087-999
17	4	1/2" Washer, Plain S.A.E. Std.	189-012106-999

MA-155L, MA-155M, MA-155M-HD, SC-230, RO-261			
Item	Quantity	Description	Part Number
18	4	Locking Nut, S.S.	151-012013-405
19	3	Connecting Rod	7201-0351-00D
20	6	Connecting Rod Bolts, and Safety Wire	7501-2713-00A
21	3	Crankpin Bearing Pair	7201-0175-00K
22	3	Wrist Pin	7201-0348-00B
23	3	Crosshead Subassembly	7201-0350-00D
24	6	Bushing	7602-3008-00B
25	3	Extension Rod	7201-0160-10B
26	3	Wiper Box (Diaphragm Stuffing Box)	7205-0006-20B
27	9	1/2" NC x 1-1/4" Hex Head Cap Screw	272-012114-999
28	9	1/2" Stat-O-Seal Washer	156-012087-999
29	3	2-1/2" I.D. x 3-1/4" O.D. Poly Pak Ring	145-212314-999
30	3	Oil Seal	145-212312-999
31	3	Gasket, Wiper Box	7502-0889-00A
32	3	3/8" NC x 1/2" Shoulder x 3-1/2" Shoulder Screw	257-038312-220
33	3	Oil Metering Plug	7201-0349-00A

Crankshaft Assembly 4-1/2" Stroke; Right-Hand and Left-Hand Drive; Right-Hand Shown

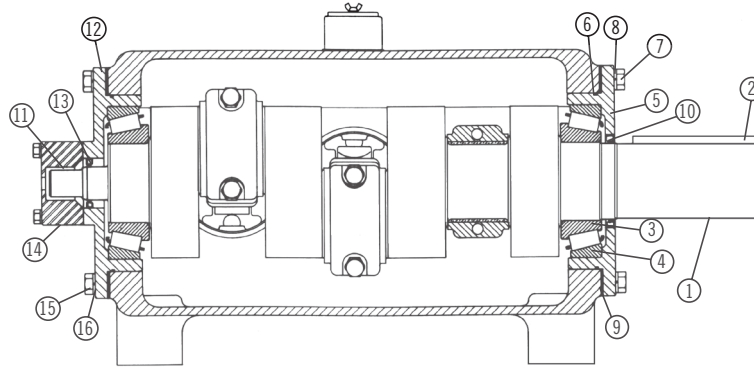

MA-155M-HD, SC-230			
Item	Quantity	Description	Part Number
1	1	Crankshaft Assembly (includes items 1 & 2)	PE293K
2	1	Crankshaft	7201-0725-00D
	1	Drive Key	146-100700-236
3	2	Crankshaft Kit (includes items 1, 2, 3, & 4)	PE293KB
	2	Bearing Cone, Tapered Roller	203-574590-999
	2	Bearing Cup	202-529590-999
5	1	Bearing Carrier, Drive Side	7201-0004-00C
6	2	O-Ring, Nitrile Rubber	001500371
7	12	3/4" NC Hex Head Cap Screw 2" Long	100-034200-273
8	12	3/4" Lockwasher, Spring Medium	154-034127-244

MA-155M-HD, SC-230			
Item	Quantity	Description	Part Number
9	2	Shim Set	7502-0237-00A
10	1	Oil Seal, Drive Side	145-458558-999
11	1	Key, Packing Lubricator Drive Side	146-038112-236
12	1	Bearing Carrier, Lubricator Side	7205-0005-00C
13	1	Oil Seal, Packing Lubricator Side	145-200300-999
*14	1	Cover Stub Shaft	7204-0099-00A
*15	2	1/2" NC x 3" Lg. Hex Hd. Cap Screw, Grade 5	100-012300-273
*16	2	1/2" Lockwasher	154-012087-244

* Items 14 thru 16 are required only if packing lubricator is NOT ordered.

Crankshaft Assembly 4-1/2" Stroke; Right-Hand and Left-Hand Drive; Right-Hand Shown

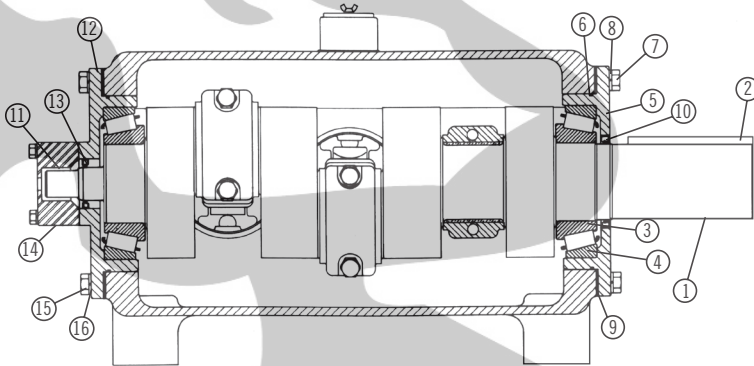

MA-155L, MA-155M, RO-261			
Item	Quantity	Description	Part Number
1	1	Crankshaft Assembly (includes items 1 & 2)	PE112K
2	1	Crankshaft	7205-0003-10D
	1	Drive Key	146-100700-236
3	2	Crankshaft Kit (includes items 1, 2, 3, & 4)	PE112KB
	2	Bearing Cone, Tapered Roller	203-574590-999
	2	Bearing Cup	202-529590-999
5	1	Bearing Carrier, Drive Side	7201-0004-00C
6	2	O-Ring, Nitrile Rubber	001500371
7	12	3/4" NC Hex Head Cap Screw 2" Long	100-034200-273
8	12	3/4" Lockwasher, Spring Medium	154-034127-244

MA-155L, MA-155M, RO-261			
Item	Quantity	Description	Part Number
9	2	Shim Set	7502-0237-00A
10	1	Oil Seal, Drive Side	145-458558-999
11	1	Key, Packing Lubricator Drive Side	146-038112-236
12	1	Bearing Carrier, Lubricator Side	7205-0005-00C
13	1	Oil Seal, Packing Lubricator Side	145-200300-999
*14	1	Cover Stub Shaft	7204-0099-00A
*15	2	1/2" NC x 3" Lg. Hex Hd. Cap Screw, Grade 5	100-012300-273
*16	2	1/2" Lockwasher	154-012087-244

** Items 14 thru 16 are required only if packing lubricator is NOT ordered.

Fluid End Assembly

MA-155L, RO-261			
Item	Quantity	Description	Part Number
1	3	Valve Cover	7201-0088-00C
2	3	Valve Cover Seal	7201-0008-00A
3	3	3/4" Hex Hd. Pipe Plug, S.S.	170-034002-405
4	1	Liquid End, Nickel Aluminum Bronze	7201-0080-00E
5	12	1-1/4" x 5-7/8" Stuffing Box Stud	7507-2738-00A
6	16	3/4" x 3-1/2" Stud, Discharge Flange	7507-2735-00A
7	12	1-1/4" x 4" Valve Cover Stud	7507-2737-00A
8	24	1-1/4"-8 NC Nut, Heavy Hex	141-114008-243
9	16	3/4" x 3" Stud, Suction Flange	7507-2795-00A
10	16	3/4" NC Nut, Heavy Hex	133-034010-243
11	4	1-1/8" x 3" Sk. Hd. Cap Sw., Liquid End to Power Frame	105-118234-454

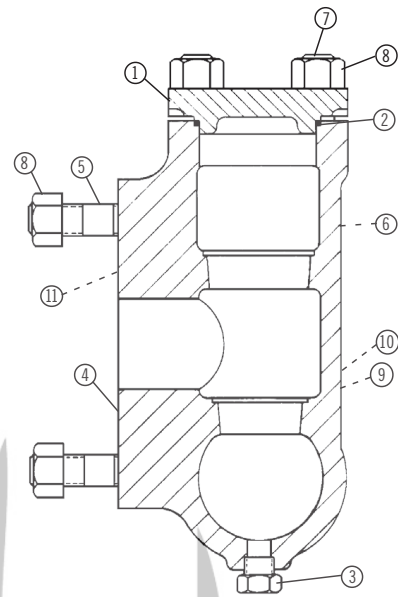

Fluid End Assembly

MA-155M, MA-155M-HD			
Item	Quantity	Description	Part Number
1	3	Valve Cover	7201-0087-00B
2	3	Valve Cover Gasket	7201-0081-00B
3	3	3/4" Hex Hd. Pipe Plug, S.S.	170-034002-405
4	1	Liquid End, Nickel Aluminum Bronze	7201-0079-00E
5	12	1-1/4" x 5-7/8" Stuffing Box Stud	7507-2738-00A
6	12	1-1/4"-8 Thrd. Nut, Heavy Hex	141-114008-243
7	16	7/8" x 3-7/8" Stud, Discharge Flange	7507-2736-00A
8	16	7/8"-9 Thrd. Nut, Heavy Hex	133-078009-243
9	12	1" x 3-5/16" Valve Cover Stud	7507-2793-00A
10	12	1"-8 Thrd. Nut, Heavy Hex	133-100008-243
11	16	5/8" x 2-3/4" Stud, Suction Flange	7507-2732-00A
12	16	5/8"-11 Thrd. Nut, Heavy Hex	133-058011-243
13	4	Bolt, Socket Head; 1-1/8 x 2-3/4" Lg., Liquid End to Power Frame	105-118234-454

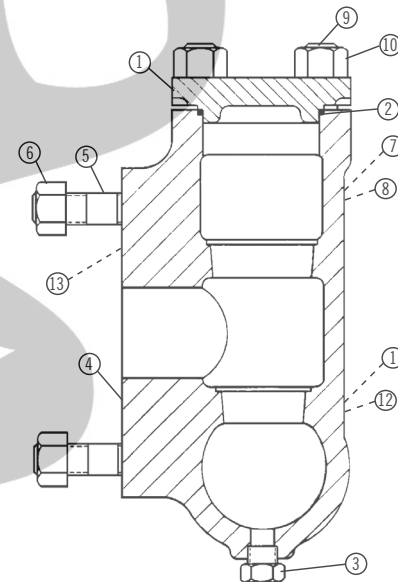

BUCKHORN PUMPS, INC.

Fluid End Assembly

SC-230			
Item	Quantity	Description	Part Number
1	1	Fluid End, Steel	Consult Factory
2	6	Valve & Cylinder Cover	7201-0575-00B
3	6	Valve & Cylinder Cover Seal	7201-0008-00A
4	12	1-1/4" x 5-7/8" Stud, Stuffing Box	7507-2738-00A
5	24	1-1/4" x 4" Stud, Valve Cover	7507-2737-00A
6	24	1-1/4"-8 Thrd., Nut, Hvy. Hex	141-114008-243
7	3	1/2" Pipe Plug, Hex Hd.	170-012002-405
8	4	1-1/8" Socket Hd. Cap Screw	105-118234-454

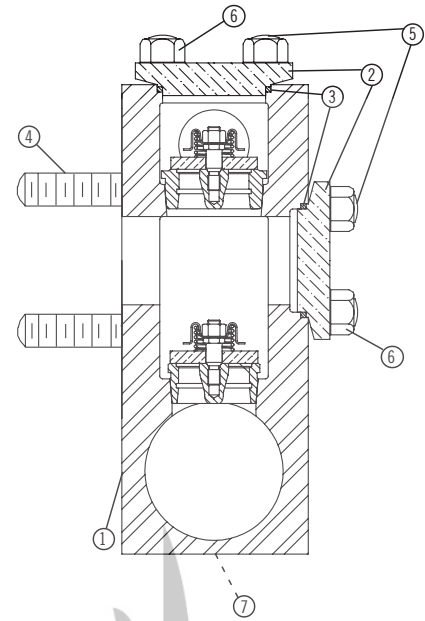

Fluid End Assembly

MA-155M, MA-155M-HD			
Item	Quantity	Description	Part Number
1	3	Valve Cover	7201-0587-00C
2	3	Valve Cover Seal	7201-0081-00B
3	3	1/2" Hex Hd. Pipe Plug	170-012002-250
4	1	Liquid End, Forged Steel	Consult Factory
5	12	1-1/4" x 5-7/8" Stuffing Box Stud	7507-2738-00A
6	12	1-1/4"-8 Thrd. Nut, Heavy Hex	141-114008-243
7	16	7/8" x 3-7/8" Stud, Discharge Flange	Variable
8	12	1" x 3-5/16" Valve Cover Stud	7507-2793-00 A
9	12	1"-8 Thrd. Nut, Heavy Hex	133-100008-243
10	16	5/8" x 2-3/4" Stud, Suction Flange	Variable
11	4	1-1/8"-7 UN x 2-3/4" Sk. Hd. Cap Sw., Liquid End to Power Frame	100-118234-454

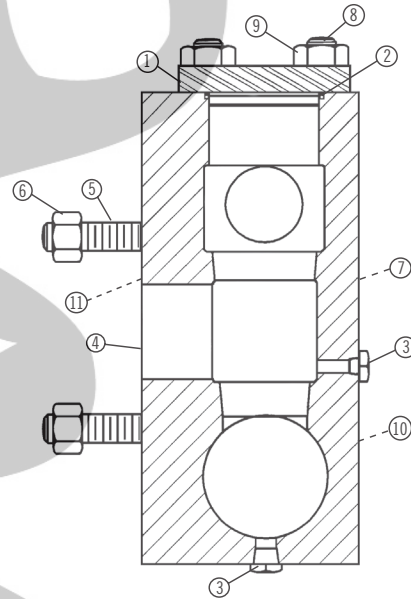

BUCKHORN PUMPS, INC.

Stuffing Box Assembly

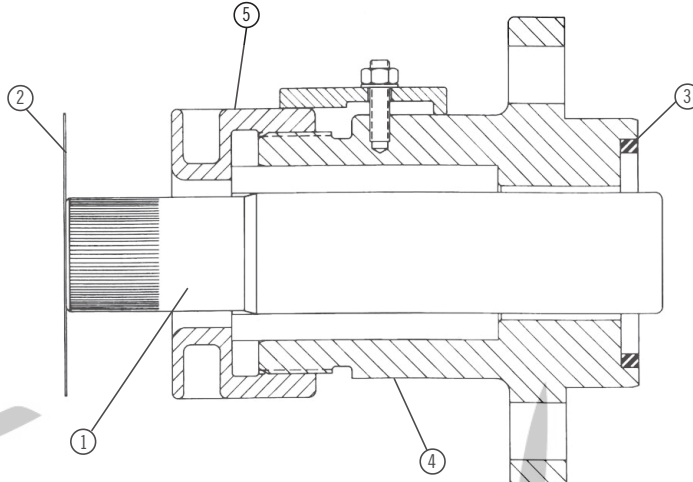

Qty. 3 per pump ea.

MA-155L, RO-261							
Plunger Diameter	Plunger, Chrome-Oxide (#1)	Baffle (#2)	Stuffing Box Seal, Nitrile Rubber (#3)	Stuffing Box, Steel (#4)	Stuffing Box, Alum. Bronze (#4)	Gland Steel (#5)	Gland Nut Alum. Bronze (#5)
4"	7201-0325-32B	7201-0039-00A	7201-0007-00A	7201-0584-00B	7201-0054-10C	7201-0582-00B	7201-0002-00B
3-7/8"	7201-0325-31B	7201-0039-00A	7201-0007-00A	7201-0584-00B	7201-0054-10C	7201-0582-00B	7201-0002-00B
3-3/4"	7201-0325-30B	7201-0039-00A	7201-0007-00A	7201-0584-00B	7201-0054-10C	7201-0582-00B	7201-0002-00B
3-5/8"	7201-0325-29B	7201-0039-00A	7201-0007-00A	7201-0584-00B	7201-0054-10C	7201-0582-00B	7201-0002-00B
3-1/2"	7201-0325-28B	7201-0039-00A	7201-0007-00A	7201-0790-10C	7201-0050-10C	7201-0001-10B	7201-0001-00B
3-3/8"	7201-0325-27B	7201-0039-00A	7201-0007-00A	7201-0790-10C	7201-0050-10C	7201-0001-10B	7201-0001-00B
3-1/4"	7201-0325-26B	7201-0039-00A	7201-0007-00A	7201-0790-10C	7201-0050-10C	7201-0001-10B	7201-0001-00B
3-1/8"	7201-0325-25B	7201-0039-00A	7201-0007-00A	7201-0576-00B	7201-0067-10C	7204-0376-00B	7201-0060-00B
3"	7201-0325-24B	7201-0039-00A	7201-0007-00A	7201-0576-00B	7201-0067-10C	7204-0376-00B	7201-0060-00B
2-7/8"	7201-0325-23B	7201-0039-00A	7201-0007-00A	7201-0576-00B	7201-0067-10C	7204-0376-00B	7201-0060-00B

GLAND NUT WRENCH 7201-0342-00B

Stuffing Box Assembly

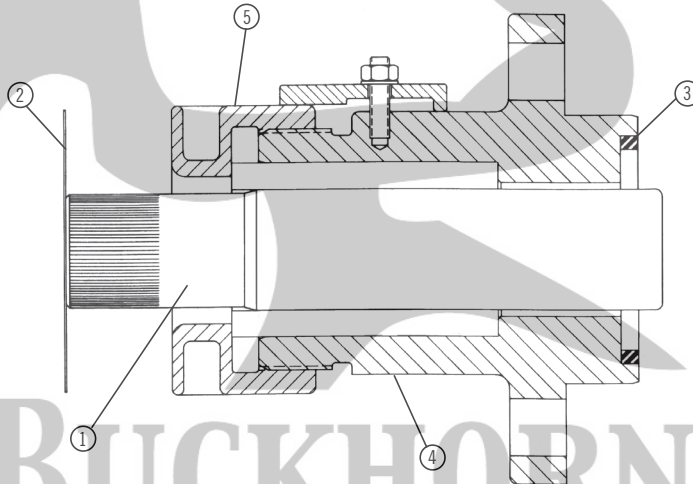

Qty. 3 per pump ea.

MA-155M, MA-155M-HD							
Plunger Diameter	Plunger, Chrome-Oxide (#1)	Baffle (#2)	Stuffing Box Seal, Nitrile Rubber (#3)	Stuffing Box, Steel (#4)	Stuffing Box, Alum. Bronze (#4)	Gland Steel (#5)	Gland Nut Alum. Bronze (#5)
2-3/4"	7201-0325-22B	7201-0039-00A	7201-0033-00A	7201-0590-10B	7201-0026-10B	7201-0591-10B	7201-0025-00B
2-5/8"	7201-0325-21B	7201-0039-00A	7201-0033-00A	7201-0590-10B	7201-0026-10B	7201-0591-10B	7201-0025-00B
2-1/2"	7201-0325-20B	7201-0039-00A	7201-0033-00A	7201-0590-10B	7201-0026-10B	7201-0591-10B	7201-0025-00B
2-3/8"	7201-0325-19B	7201-0039-00A	7201-0033-00A	7201-0590-10B	7201-0026-10B	7201-0591-10B	7201-0025-00B
2-1/4"	7201-0325-18B	7201-0039-00A	7201-0033-00A		7201-0038-10B		7201-0068-00B
2-1/8"	7201-0325-17B	7201-0039-00A	7201-0033-00A		7201-0038-10B		7201-0068-00B
2"	7201-0325-16B	7201-0039-00A	7201-0033-00A		7201-0038-10B		7201-0068-00B
1-7/8"	7201-0325-15B	7201-0039-00A	7201-0033-00A		7201-0038-10B		7201-0068-00B
1-3/4"	7201-0325-14B	7201-0039-00A	7201-0033-00A		7201-0038-10B		7201-0068-00B

GLAND NUT WRENCH 7201-0342-00B.

4-1/2" Piston Assembly

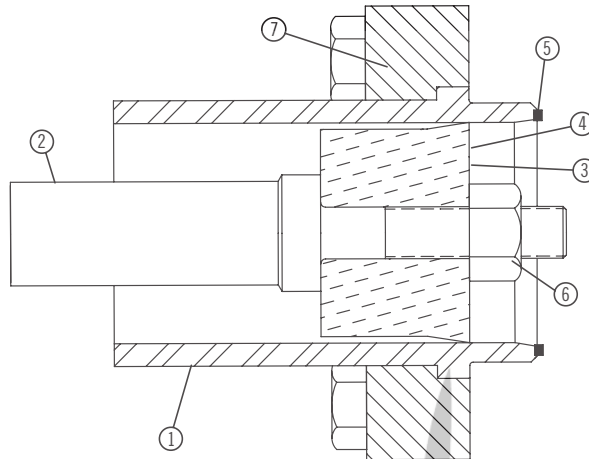

Qty. 3 per pump ea.

SC-230			
Item	Quantity	Description	Part Number
1	1	Piston Liner, High Chrome Iron	7201-0729-00K
2	1	Piston Rod	7201-0728-00B
3	1	Piston Cup Assembly, 4-1/2", Black Rubber	7201-0731-00K
4	1	Piston Rubber, Furnished with Above	7201-0732-00A

SC-230			
Item	Quantity	Description	Part Number
5	1	Seal, Liner	7201-0727-00A
6	1	Nut, Piston Rod, Self Locking	151-100008-273
7	1	Piston Liner Flange	7201-0730-00B
8	1	Baffle (Not Shown)	7201-0039-00A

4-1/2" Piston Assembly

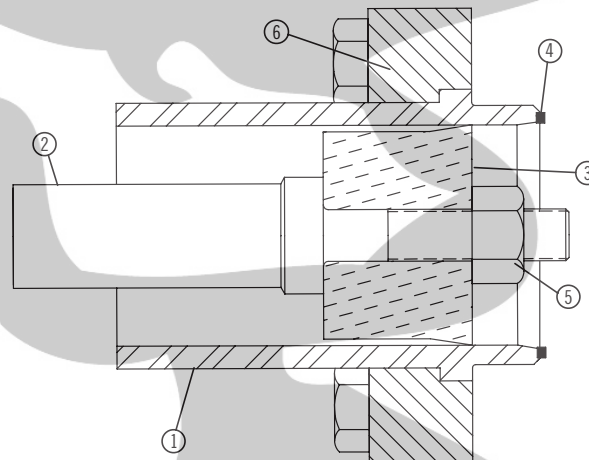

Qty. 3 per pump ea.

SC-230			
Item	Quantity	Description	Part Number
1	1	Piston Liner, High Chrome Iron	7201-0729-00K
2	1	Piston Rod	7201-0728-00B
3	1	Piston Cup Assembly, 4-1/2", Polyurethane	7201-0781-00K
4	1	Seal, Liner	7201-0727-00A

SC-230			
Item	Quantity	Description	Part Number
5	1	Nut, Piston Rod, Self Locking	151-100008-273
6	1	Piston Liner Flange	7201-0730-00B
7	1	Baffle (Not Shown)	7201-0039-00A

BUCKHORN
PUMPS, INC.

STANDARD LIMITED WARRANTY CENTRIFUGAL & RECIPROCATING PUMPS

Pentair Myers® warrants its products against defects in material and workmanship for a period of 12 months from the date of shipment from Pentair Myers or 18 months from the manufacturing date, whichever occurs first – provided that such products are used in compliance with the requirements of the Pentair Myers catalog and technical manuals.

During the warranty period and subject to the conditions set forth, Pentair Myers, at its discretion, will repair or replace to the original user, the parts that prove defective in materials and workmanship. Pentair Myers reserves the right to change or improve its products or any portions thereof without being obligated to provide such a change or improvement for prior sold and/or shipped units.

Seals, piston cups, packing, plungers, liners and valves used for handling clear, fresh, nonaerated water at a temperature not exceeding 120°F are warranted for ninety days from date of shipment. All other applications are subject to a thirty day warranty. Accessories such as motors, engines and auxiliary equipment are warranted by the respective manufacturer and are excluded in this standard warranty. Under no circumstance will Pentair Myers be responsible for the cost of field labor, travel expenses, rented equipment, removal/reinstallation costs or freight expenses to and from the factory or an authorized Pentair Myers service facility.

This limited warranty will not apply: (a) to defects or malfunctions resulting from failure to properly install, operate or maintain the unit in accordance with the printed instructions provided; (b) to failures resulting from abuse, accident or negligence; (c) to normal maintenance services and parts used in connection with such service; (d) to units that are not installed in accordance with applicable local codes, ordinances and good trade practices; (e) if the unit is moved from its original installation location; (f) if unit is used for purposes other than for what it is designed and manufactured; (g) to any unit that has been repaired or altered by anyone other than Pentair Myers or an authorized Pentair Myers service provider; (h) to any unit that has been repaired using non factory specified/OEM parts.

Warranty Exclusions: PENTAIR MYERS MAKES NO EXPRESS OR IMPLIED WARRANTIES THAT EXTEND BEYOND THE DESCRIPTION ON THE FACE HEREOF. PENTAIR MYERS SPECIFICALLY DISCLAIMS THE IMPLIED WARRANTIES OF MERCHANTABILITY AND FITNESS FOR ANY PARTICULAR PURPOSE.

Liability Limitation: IN NO EVENT SHALL PENTAIR MYERS BE LIABLE OR RESPONSIBLE FOR CONSEQUENTIAL, INCIDENTAL OR SPECIAL DAMAGES RESULTING FROM OR RELATED IN ANY MANNER TO ANY PENTAIR MYERS PRODUCT OR PARTS THEREOF. PERSONAL INJURY AND/OR PROPERTY DAMAGE MAY RESULT FROM IMPROPER INSTALLATION. PENTAIR MYERS DISCLAIMS ALL LIABILITY, INCLUDING LIABILITY UNDER THIS WARRANTY, FOR IMPROPER INSTALLATION. PENTAIR MYERS RECOMMENDS INSTALLATION BY PROFESSIONALS.

Some states do not permit some or all of the above warranty limitations or the exclusion or limitation of incidental or consequential damages and therefore such limitations may not apply to you. No warranties or representations at any time made by any representatives of Pentair Myers shall vary or expand the provision hereof.



MYERS®
MYERS® APLEX SERIES

1101 MYERS PARKWAY
ASHLAND, OHIO, USA 44805
419-289-1144

WWW.FEMYERS.COM

Warranty Rev. 12/13

BUCKHORN PUMPS, INC.