

Parts & Service Manual

Kerr KJ-2250/KJ-2250BC Plunger Pump

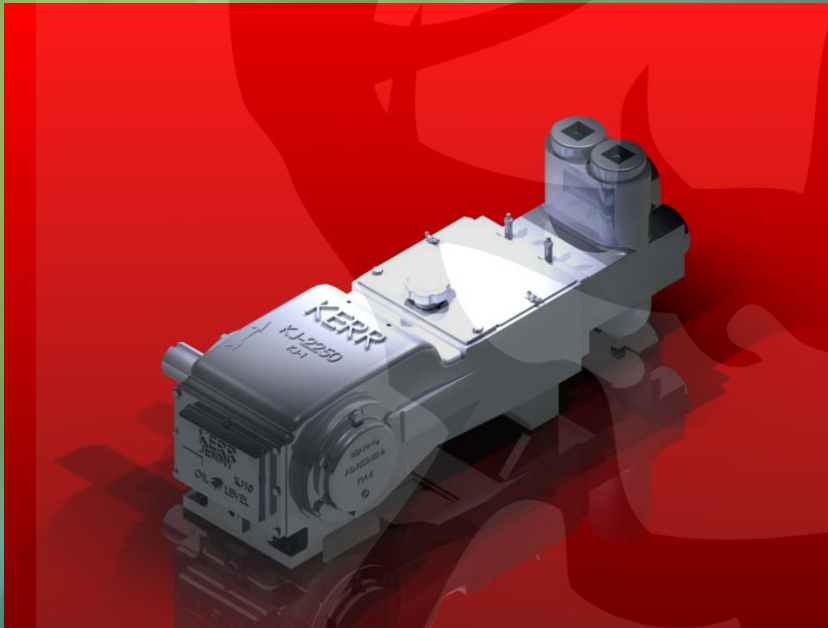

Kerr Pump Corporation

Post Office Box 735 2214 West 14th Street
Sulphur, Oklahoma 73086
Phone: 580-622-4207 Fax: 580-622-4206
Website-www.kerrpumps.com
Email-information@kerrpumps.com
United States and Canada
800-441-8149



KERR PUMP CORPORATION SERVICE MANUAL

EIGHTEENTH EDITION

NEW PUMP WARRANTY

- A. Kerr Machine Co. (**Kerr Pump Corporation**) warrants its new pumps to be free from defective materials and/or workmanship for a period of one year from the date of sale by the Distributor, provided that the new pump is registered in accordance with Paragraph No. 2 hereof, properly installed and operated in accordance with the Company's Service Manual, and all other terms of this warranty agreement are complied with by the purchaser. As hereinafter provided, this warranty includes the replacement of parts and labor to correct any deficiency. All defective parts must be returned to the Company's Home Office for examination before this warranty is effective. This warranty applies to parts, which have been replaced under this warranty only so long as the original pump warranty is effective. This warranty is for the exclusive benefit of the purchaser and is not transferable.
- B. Each Distributor of a new pump will provide the customer with a registration blank furnished to him by the Company which must state the date of sale, be signed by the purchaser and the Distributor, and delivered to the Home Office of the Company within fifteen (15) days of the date of sale.
- C. In the event of a claim under this warranty, made within the one-year warranty period, the purchaser must notify the Distributor, and the Distributor shall contact **Kerr Pump Corporation** before any repairs or service calls are made.
- D. All warranty claims must be sent to **Kerr Pump Corporation** Home Office on the authorized warranty claim form provided by **Kerr Pump Corporation**, and available from the Distributor before any warranty claim will be considered. It is understood that **Kerr Pump Corporation** will deteriorate due to ordinary wear, therefore, the following credits shall apply to all replacement parts, labor, surface freight, travel time and mileage allowance furnished under this warranty.
 - i. For the first ninety (90) days from the date of sale by the Distributor, 100% credit will be allowed on a current list price basis.
 - ii. From 91 to 180 days from the date of sale by the Distributor, 75% credit will be allowed on a current list price basis.
 - iii. From 181 days to 270 days by the Distributor, 50% credit will be allowed on a current list price basis.
 - iv. From 271 days to one year after the date of sale by the Distributor, 25% credit will be allowed on a current list price basis.

The credit given to the Distributor for replacement parts or pumps under this warranty is based upon the Distributor's net cost paid Kerr Pumps for such replacement parts or pumps.

- E. In the event of a warranty claim under this warranty made within ninety (90) days of the date of sale by the Distributor, **Kerr Pump Corporation**, before any repairs are made, shall be contacted by the Distributor and given the option of having the Distributor either repair or replace the pump.
- F. Upon any claim under this warranty, other than a claim wherein Kerr Pump Corporation at its option replaced the pump as provided in Paragraph No. 5 hereof, the Distributor will make the necessary repairs an/or replacement, and Kerr Pump Corporation shall allow the cost of labor on warranty claims. The labor cost may include travel time not to exceed (8) hours of actual travel time. Kerr Pump Corporation will pay surface freight on warranty shipments. After making the necessary repairs and/or replacements, the Distributor will bill the customer for the full amount due for the repair. Thereafter, the Distributor will submit the warranty claim form provided by **Kerr Pump Corporation** to the **Kerr Pump Corporation** Home Office for consideration. In the event the warranty claim is honored by **Kerr Pump Corporation** a Credit Memorandum will be issued to the Distributor in the amount determined by the table in Paragraph No. 4 hereof. Thereafter, the customer's invoice will be credited by the Distributor in the same percentage allowed the Distributor by **Kerr Pump Corporation**.
If requested by **Kerr Pump Corporation** the purchaser or the Distributor shall return the alleged defective product to **Kerr Pump Corporation** factory, freight prepaid, for examination and testing. If **Kerr Pump Corporation** determines the product is defective **Kerr Pump Corporation** will either repair or replace such product with a like of **Kerr Pump Corporation** manufacture, f.o.b. to the Distributor or allow the Distributor credit to an amount equal to the invoiced value of the defective product. The responsibility of **Kerr Pump Corporation** is limited to the repairing or replacing defective material manufactured by it, provided **Kerr Pump Corporation** examination discloses to its satisfaction that such material has not been altered or repaired, other than by **Kerr Pump Corporation** approved procedures, subject to misuse, improper maintenance, negligence or accident. **Kerr Pump Corporation** will not be responsible for loss of liquid or for damage of any kind, or from any cause, to any person or property of any person, or for loss of revenue of profit, or for any other special incidental or consequential damages.
- G. The warranty applies only to new **Kerr Pump Corporation**. The Company specifically excludes from this warranty the following.
- i. All plungers, valves, plunger packing, valve springs, seals gaskets, and corrosion and/or erosion damage caused by the fluid handled by the Company's pump.
 - ii. In addition, after the expiration of the pump warranty all replacement parts are no longer in warranty.
- H. In extreme cases where in the opinion of **Kerr Pump Corporation**, if a pump has been misused or is being misused, **Kerr Pump Corporation** reserves the option to offer to redeem the pump from the purchaser. Should the purchaser refuse to allow the pump to be redeemed and chooses to continue improper operation, the warranty will be void.
- I. Any parts or equipment which **Kerr Pump Corporation** supplies and does not manufacture shall be subject only to the warranties of **Kerr Pump Corporation** vendors to the extent **Kerr Pump Corporation** can enforce such warranties.
- J. Any repairs to, alterations of, or work done on alleged defective products without **Kerr Pump Corporation** specific written authorization shall void **Kerr Pump Corporation** warranty applicable thereto.
- K. Any action for breach of warranty or other action under this agreement must be commenced within (1) year after such cause of action arises.

This limited warranty is in lieu of all other warranties, expressed or implied, including any implied warranty or merchantability or fitness.

TROUBLESHOOTING GUIDE

Problem	Reason/Solution
Unusual pounding, knocking broken valve spring	<ul style="list-style-type: none">• Insufficient fluid at high speed.• Suction line is improper size or is constricted. (Trash in line, valve partly opened, etc.)• Possibility of gas in the fluid causing the roughness.
Loss of pressure or volume	<ul style="list-style-type: none">• Foreign matter may be holding valves open.• Worn valves.• Broken springs.
Consistent, rhythmic knock	<ul style="list-style-type: none">• Improper bearing adjustment.• Worn bearings or connecting rods.• NOTE: Valve noise is common and normal in high-speed pumps. It should not cause concern unless it becomes erratic.
Packing failure (Excessive)	<ul style="list-style-type: none">• Improper installation.• Improper type of lubrication.• Incorrect type of packing for particular installation.• (Contact Kerr Pump Corporation if you are unsure.)
Abnormal wear of fluid end parts	<ul style="list-style-type: none">• Abrasive or corrosive fluid.
Abnormal wear of power end parts	<ul style="list-style-type: none">• Lack of oil, overload on pump, foreign matter in oil.
Heat in power end	<ul style="list-style-type: none">• A new pump will run hot for a short period (2 or 3 days). See above for persistent heating. Pump will operate near 140° F. under average conditions.• Check for air in pump by bleeding at cover caps.• Too much spring tension Reciprocating pumps have very limited pick up.

INSTALLATION INSTRUCTIONS



WARNING

Read everything in this section before attempting to run or connect your pump.

The importance of proper installation cannot be overstressed. As the reciprocating pump is almost unable to lift fluid, proper suction flooding is a must. This is the First step toward satisfactory operation.

BUCKHORN
PUMPS, INC.

The Kerr Pumps Engineering Service will be happy to advise you in your installation problems. As almost every installation varies, you cannot exercise too much care in making certain your installation is proper.

Before Starting The Pump, read carefully the maintenance section in the following pages.

For best results, follow these installation guidelines.

- (A) PRESSURE RELIEF VALVE (REQUIRED)
- (B) BY-PASSED FLUID SHOULD BE PIPED BACK IN SUCTION SUPPLY TANK WHEN POSSIBLE
- (C) USE FLEXIBLE HOSE IN DISCHARGE LINE WHEN POSSIBLE
- (D) DISCHARGE SHUT-OFF VALVE (OPTIONAL-USED FOR TOTAL SHUT-DOWN OR SERVICE ONLY)
- (E) DISCHARGE AND SUCTION ON EITHER SIDE OF FLUID END ON ALL MODELS.
- (F) PULSATION "DAMPENERS" MAY BE USED IN EITHER THE SUCTION OR DISCHARGE PIPING OR BOTH. DISCHARGE DAMPENERS SHOULD BE CAPABLE OF HANDLING PUMP DISCHARGE MAXIMUM PRESSURE

To start the pump, open the suction line valve and permit the intake chamber to fill on the pump. Air may be bled off by opening the valve covers slightly until there is a constant fluid flow. After bleeding, open the discharge line valve and start the pump. Roughness may occur from cavitation (air in line) or from starvation (lack of fluid). Eliminate these troubles before permitting continuous operation.

**BUCKHORN
PUMPS, INC.**

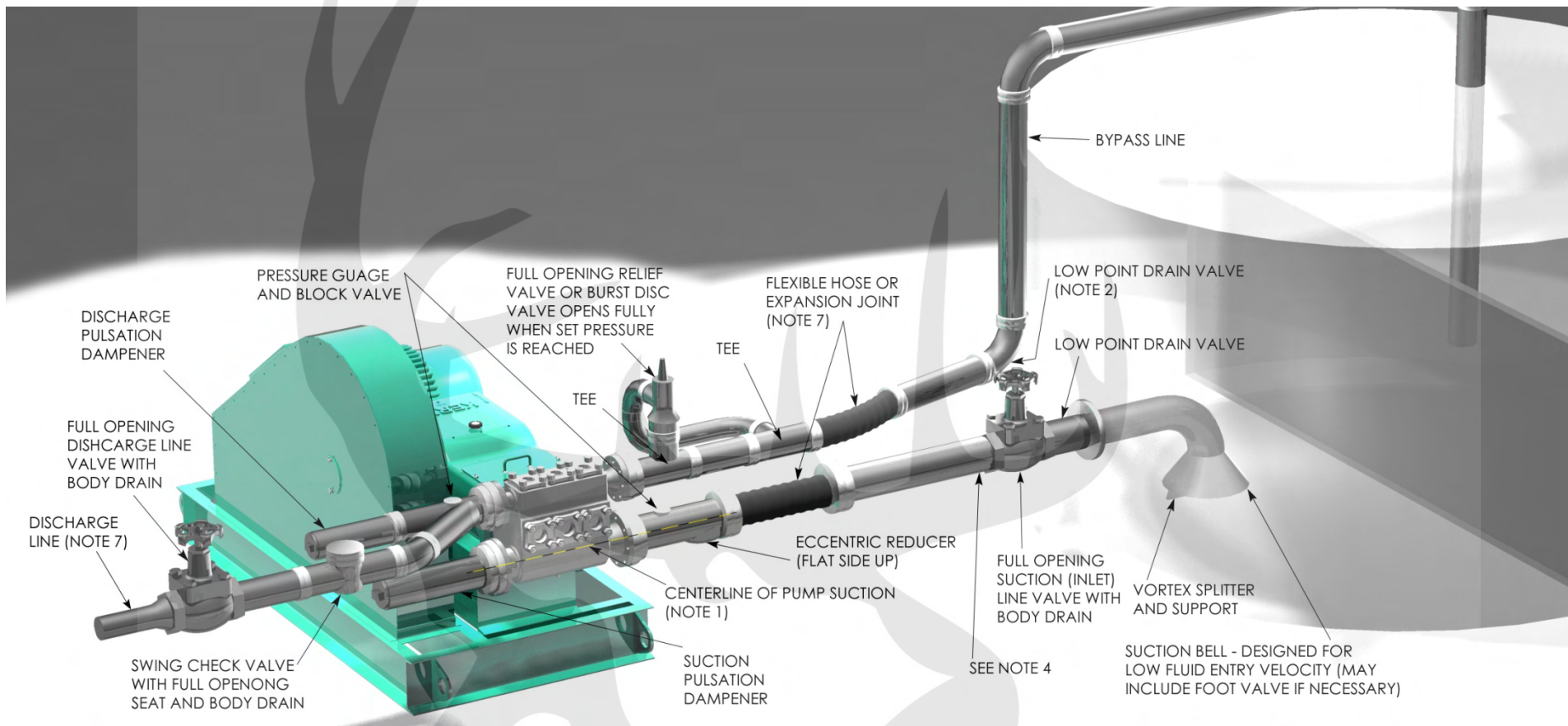

- 1) CENTERLINE OF PUMP SUCTION (INLET) TO BE SLIGHTLY HIGHER THAN CENTERLINE OF SUCTION (INLET) VALVE - SO ANY AIR IN SUCTION SYSTEM PROMPTLY REACHES PUMP AND IS EXPELLED
- 2) SLOPE BYPASS LINE SO LOW POINT DRAIN WILL FULLY EMPTY RELIEF AND CHOKE VALVES AND ALL LIQUID IN BYPASS CIRCUIT
- 3) DO NOT LOCATE PIPING OR OTHER EQUIPMENT IN FRONT OF OR ABOVE PUMP FLUID END PREVENTING SERVICING - REFER TO MANUFACTURER FOR MINIMUM CLEARANCES
- 4) LOCATE CHARGING PUMP AT POINT SHOWN. - IF CHARGING PUMP IS NECESSARY (FOR VOLATILE FLUIDS, FOR EXAMPLE)
- 5) IF DESIRED, A TWO-WAY MOTOR OPERATED BYPASS VALVE MAY BE USED RATHER THAN MANUAL TYPE - IT SHOULD BE DESIGN TO OPEN AUOMATICALLY WHILE STARTING OR STOPPING
- 6) BYPASS LINE SHOULD FEED LIQUID INTO TANK BELOW MINIMUM LIQUID LEVEL
- 7) TO REMOVE PIPING STRAIN AND VIBRATION A FLEXIBLE HOSE, EXPANSION JOINT OR SWIVLE JOINT PAIR SHOULD BE POSITIONED TO MINIMIZE EFFECTS OF PIPING THERMAL EXPANSION, CONTRACTION AND PIPING WEIGHT
- 8) SUCTION SIZED FOR 1 1/2 TO 2 FT/SEC MAX FLOW RATE. DISCHARGED SIZED FOR 8 TO 10 FT/SEC MAX FLOW RATE - SUCTION AND DISCHARGE MUST BE SUPPORTED AND ANCHORED
- 9) TO PROTECT SUCTION SYSTEM AGAINST HAZARD OF DISCHARGE PRESSURE ENTRY (AS WHEN PUMP IS IDLE), A SMALL RELIEF VALVE IS OFTEN CONNECTED HERE
- 10) ALL SYSTEM COMPONENTS MUST HAVE ADEQUATE PRESSURE RATINGS FOR OPERATING, STARTING AND UPSET CONDITIONS. IN ORDER TO REDUCE POTENTIAL HAZARDS, PARTICULAR ATTENTION IS RECOMMENDED FOR THE SURGE CONDITION THAT WILL RESULT DOWNSTREAM OF THE RELIEF VALVE WHEN NORMAL DISCHARGE IS BLOCKED



-AS A GENERAL RULE, FLUID LEVEL MUST BE HIGHER THAN THE PUMP FLUID END AS PLUNGERS CANNOT LIFT FLUID. 10 FEET OF HEAD IS A GOOD RULE OF THUMB.

-CAUTION SHOULD BE TAKEN TO KEEP FITTINGS OUT OF THE SUCTION AND DISCHARGE PIPING AS THESE WILL RESULT IN POOR PERFORMANCE. EACH 90-DEGREE TURN IN THESE LINES RESULTS IN GREAT LOSS OF PUMPING EFFICIENCY.

BUNKER HORN
PUMPS, INC.

PREVENTIVE MAINTENANCE

DAILY

A. Check and Maintain Lubricant Levels.

Standard Lubricant:

AGMA Grade (ASTM D 2422): 4 EP

ISO Viscosity Grade: 150

Viscosity in SSU @ 100 degree F: 625-765

Synthetic Lubricant:

SAE Viscosity Grade (J306-8): 75W-90

MONTHLY

- A. Drain and refill crankcase. It is recommended that oil be changed after the first week of operation.
- B. Wash oil filler cap in kerosene.
- C. Check valves for excessive wear, broken or bent springs, etc.
- D. Check crankshaft bearings for endplay. (See section on crankshaft)
- E. Keep all nuts, studs, etc. tight.
- F. Check valve covers for leaks.
- G. Check all seals and gaskets for leaks

PUMP CAPACITIES (APPROXIMATE)

KD-1250	2 qts.	KT-3350	16 qts.
KJ-2250	3 qts.	KT-3400	16 qts.
KZ-3150	2 qts.	<i>Use SAE 30 weight non-detergent motor oil ONLY</i>	
KM-3250	4 qts.	KB-3500	20 qts.
KM-3300	4 qts.	KA-3500	36 qts.
KP-3300	12 qts.	KSB-6400	36 qts.
R335/R340	16 qts.	KSB-6500	36 qts.
Q5450	22.5 gal.	KCP-6300	24 qts.

BUCKHORN
PUMPS, INC.

PLANETARY GEAR REDUCERS

#6	17 ozs.
#8	42 ozs.
#9	42 ozs.

- B. If pump has lubricating facilities for stuffing boxes, check level of lubricant.
- C. Maintain packing gland tension on packing (Do not over-tighten)
- D. Visually inspect pump for apparent trouble.
- E. Keep the pump clean.

GENERAL

Replace any work part before its eventual failure. Use the following instructions for removal and replacement of parts. Don't hesitate to call on **Kerr Pumps** for help if necessary.

SERVICE PROCEDURES (ALL MODELS)

A. WING GUIDED VALVES

- i. **DISCHARGE VALVES:** The discharge valve and seat can be exposed by first removing the discharge valve cover cap. Once the discharge cover cap has been removed you may lift out the discharge valve spring and the discharge valve. The valve seat will be held in place by a taper fit and must be "pulled" with an appropriate valve-pulling tool (available from the **Kerr Pumps** Dealers). Once the valve and seat have been removed they should be resurfaced or replaced if badly worn. To replace the discharge valve, first clean and inspect the seat bore for washout defects and then drop the seat into the bore. Replace the valve into the seat and strike the top of

the valve a couple of good blows utilizing a brass bar and hammer to seat the valve seat in the fluid end valve bore. Replace the valve spring and cover cap after inspecting the spring and the seal of the cover cap.

- ii. SUCTION VALVES: The suction valves are located in the chamber directly below the suction or end valve cover caps. The suction valves are serviced in the identical manner as the discharge valves. Note: Discharge valves must be removed prior to any removal of the suction valves.

Service Procedure for KZ-3150 Valves

- iii. DISCHARGE VALVES: The discharge valve and seat can be exposed by first removing the discharge valve cover plate. Once the discharge cover cap has been removed you may lift out the discharge valve spring, discharge valve and valve seat. Once the valve and seat have been removed they should be replaced if badly worn. To replace discharge valve, first clean and inspect the seat bore for wash out defects and then drop the seat into the bore. Replace valve in seat then valve spring and cover cap, always-inspecting o'ring seals between seats and cover caps.
 - iv. SUCTION VALVES: The suction valves are located in the chamber directly below the discharge valve seat. The suction valves are serviced in the identical manner as the discharge valves.
- B. DISC TYPE VALVES: All disc-type valves are exposed for removal in a similar manner as the wing-guided valves. Instead of removing the valve body; the upper portion of the valve is removed by removal of the valve capscrew, spring retainer, valve spring, and valve spacer sleeve. The valve seat is then “pulled” from the fluid-end utilizing an authorized Kerr Valve Puller. Note: In all **Kerr Pumps** with disc-type valves the discharge and suction valves are identical.
- C. BALL AND SEAT VALVES: In pumps with block/billet type fluid-ends the valves are ball and seat design. These are exposed for removal/inspection by removal of the appropriate valve cover. The flat seats are kept in place by a screw-in valve retainer that can be best removed with a Kerr Valve Wrench made for the appropriate pump. Springs are normally incorporated with the discharge valves while the suction valves operate with a “free ball”. A copper washer/gasket is used under all valve seats for a seal. When installing or removing a flat type valve seat a good “rap” on top of the valve wrench will “seat/unseat” the seat and copper gasket prior final tightening or removal. Failure to “seat” the valve seat in this manner can result in the “washing out” of the fluid-end. For *pressurized suction*, valves will need to be spring loaded. Call **Kerr Pumps** for this change.
- D. PLUNGERS: Following the removal of the suction valve, the plunger may be removed by breaking the union between the plunger and pony rod and forcing the plunger out the back of the fluid-end. Loosening the packing nut/gland will facilitate the removal of the plunger. The reverse of this procedure is used to install a plunger. Lubrication and some slight force may be used to pass plunger through the packing.

Always retighten the plunger and pony rod union periodically following the removal of the plunger to insure it is securely made up and will not vibrate loose.

- E. **PLUNGER PACKING:** This manual includes illustrations of the packing sets for each model pump. Generally, once the plunger has been removed from the pump, the packing can be exposed for removal by completely removing whatever device is used to tighten the packing (i.e. the packing or stuffing box nut or gland). There will be various amounts of metal rings and packing components depending upon the type of packing and the model of pump (refer to appropriate illustration or chart). After the removal of all rings and equipment from the stuffing box; thoroughly clean it and inspect for damage, which might keep the new packing from working properly. If the stuffing box is in satisfactory condition, install the new packing as per the appropriate illustration. It is a good idea to lubricate new packing with a light oil prior to installation. Most of the standard packing used in pumps should be tightened with the original equipment-packing wrench while the pump is running under normal operating pressure. After a two or three hour run-in, check the packing for tightness and re-adjust as necessary. Packing should be checked for tightness on a periodic basis, but it is not a good idea to attempt to periodically tighten the packing as part of routine maintenance. This tends to “wear out” the packing prematurely. When the packing leaks in an excessive amount it should be replaced. There is no value in constantly “re-tightening” leaking packing.

If your pump is equipped with optional “spring loaded” packing, there is no adjustment in this equipment during its operational life. The stuffing box nut is initially tightened as much as possible and there is no further adjustment. Note: In all cases the spring goes in the stuffing box before the packing rings.

When using the optional Kevlar or Teflon packing, be sure to rotate the “splits” so that none are “aligned” to insure that the packing holds properly. Normally, this packing is not lubricated and requires less tension on the stuffing box nut during operation.



CAUTION: An “airtight” seal is not desirable with this plunger packing. Some slight dripage is desirable during operation. Attempts to tighten packing until it completely “seals off” will result in premature failure from too much friction. The Kevlar & Teflon packing must be allowed to drip a small amount to assure normal life.

- F. **PONY ROD and PONY ROD PACKING:** Kerr Pumps use two pony rod sealing arrangements, models KD-1250, KJ-2250, KM-3250 and KCP-6300 use a screw in seal gland, all other models use a bolt in seal gland, these glands use press in oil seals with snap ring retainers. Some Bolt in gland use adjustable packing arrangements with bolt in or screw in followers to adjust packing. By unscrewing plunger from pony rod a gap may be facilitated to allow the removal of the various sealing arrangements. A special wrench will be needed to remove and replace pony rod to crosshead. (This wrench is available from **Kerr Dealers**) All pony rods have a jam nut to align tighten pony rod to crosshead, care must be exercised in installing new seal on pony rod not to damage it.

G. DISASSEMBLY OF POWER END



CAUTION: Prior to disassembly of any power end, the plunger, pony rod, and pony rod seal housing must be removed.

Expose the crankshaft and connecting rods by removing the pan cover. Connecting rod caps may now be removed and the connecting rod and crosshead should be shoved all the way to the rear (toward the fluid end) to facilitate crankshaft removal out either side as convenient. The connecting rods and crossheads may now be taken out the front cavity exposed by removing the crankshaft. Connecting rods may be removed from the crosshead by loosening the setscrew and driving out the wrist pin from the crosshead. A bronze bushing is used in the rod it may be driven out of the rod and replaced with a new bushing. Reassembly is the reverse of the above outlined sequence with the following considerations for “fits” or tolerance:

- i. General: All Kerr components are machined on modern production machine tools and are of the same specifications and close tolerances you would expect in a modern automobile engine. It must be pointed out that at top speed (350 to 400 RPM) your pump will not even be approaching idle speed for a gasoline engine so “field fits” are possible and practical when making repairs and replacements away from the factory. All procedures outlined below are possible with only hand tools and absolutely no instruments, special tools, or gauges are needed.
- ii. Connecting rod and wrist pin: Proper fit will find the wrist pin turning freely in its bore in the connecting rod, but it should have no “wobble” that is discernable up and down the main axis of the connecting rod. This looseness in the wrist pin fit is the most probable cause of “knocking” which is traceable to the power end of most all pumps. The only solution for loose fitting wrist pins is to discard the connecting rod wrist pin bushing and replace with a new one. If any wear is visible on the wrist pin it should always be replaced.
- iii. Crankshaft End Play and Lateral adjustments: Adjustment of the Taper Roller bearings used in all Kerr Pumps is accomplished by removing or adding shims under the bearing housing. Shims are taken out or added until the crankshaft (without connecting rods) will turn freely, but with no endplay felt when attempting to pull or push the jackshaft end of the crankshaft along its long axis. Some lateral adjustment is possible by removing shims from one side of the crankshaft and adding them to the opposite side. (Note: Lateral adjustment is the “centering” of the crankshaft in the power frame housing.)
- iv. Connecting Rod to Crankshaft fitting: Factory bored connecting rods will normally fit the standard crankshaft journal just by bolting the cap on the rod with the standard rod shims being used. If the caps do require adjustment this is accomplished by removing or adding various thicknesses of rod shims. The standard connecting rod shim used on all Kerr Pumps is 1/32” thick and is comprised of .002” laminates, which can be “peeled “ off separately. Proper fit of the connecting rod will allow the pump crankshaft to be rotated while not allowing in-and-out slack in the connecting rod along its long or main axis. A well-fitted rod will have none of the in-and-out slack, but should be free enough to be moved from side to side on the rod journal. This insures the rod not being too tight. A point of

caution when installing the connecting rod assembly in the pump is to make certain the oil holes in the rod are “UP” and not toward the bottom of the pump. This will result in lubrication failure in these parts and the pump will fail in a short period of time. An additionally important step is to make sure that the rod cap is bolted back on the rod as it came off. The rod and cap carry a “mark” or “number” which allows you to match them back properly. Failure to do this will cause the rod not to fit the journal for which it was made.

- H. Power End/Fluid End Connection: A common misconception is that there is some form of fluid seal between the power end and the fluid end. This is false. The fluid end is merely bolted to the power frame. It can be removed by breaking the plunger connection, backing off the packing nut or gland, removing the various fluid end bolts, and sliding the entire fluid end off the power frame. Corrosion may tend to seize the two components together making their separation difficult in some isolated cases. On models KP-3300, KT-3350/KT-3400 and R335/R340 the bolted in stuffing box assemblies must be removed prior to removal of the entire fluid end. They are held in place by four studs each. On all other units the stuffing boxes can be left intact. On the remaining pumps (with the exception KD-1250B, KJ-2250B, KM-3250B, and KCP-6300) the stuffing boxes are held in place in the fluid end by a friction or “press” fit. They should be removed with a hydraulic press if possible. These press-in type stuffing boxes carry a gasket and/or an o-ring to insure a good seal. The boxes on the KD-1250B, KJ-2250B, KM-3250B, and KCP-6300 are screw-in type and carry only a copper gasket.



BUCKHORN
PUMPS, INC.



TECHNICAL DATA SHEET

T.D.S. NO.

4.2

PCN: _____

Supercedes PCN: _____

Date

03-10-06

SHORT TERM STORAGE PREPARATION PROCEDURE

1.0 SCOPE

This procedure applies to Kerr Pumps ONLY. Storage procedures for any other unit components or accessories (gear reducers, engines, etc.) are to be prepared to the specific manufacture's recommendations.

- 1.1 Short-term storage is defined as storage and/or transient time less than six (6) months in an environment defined in Paragraph 2. If storage exceeding six months is expected, the Long Term Pump Storage Preparation Procedure should be followed.
- 1.2 Kerr Pumps will only prepared for short term storage if so specified in the purchaser or customer order control document.

2.0 STORAGE ENVIRONMENT

A minimal environmental condition, to be met by the customer or purchaser, is a closed shelter to eliminate effects of sun, wind, sand or other debris. Large temperature and humidity changes should be avoided to prevent coating deterioration or contamination by moisture.

3.0 PRESERVATIVE PRODUCT

- 3.1 The specified rust preservative will protect the internal power end parts from corrosion due to atmospheric moisture, and may be left in the pump when filled with appropriate lubricant and placed into service. The elevated temperature of service will cause rapid depletion of the preventative protection.
- 3.2 The following rust preventative products or their equivalents are recommended for use in Kerr Pumps and usually available in 5 gallon, 55 gallon containers:
 - CITGO: RUST-O-LINE OIL 10
 - SHELL: ENSIS OIL N

4.0 PROCEDURE

- 4.1 Preparation from; factory testing, inventory, or a distributor rebuild facility.
 - Drain any oil that may be in the power end, and then fill the complete power end cavity with the specified rust preventative. After 15 to 20 minutes, drain the rust preventative back into its storage drum for future use.
 - Remove and clean oil level gages, pressure gages and breather caps. Replace with pipe plugs in threaded openings. All breathers shall be replaced with airtight seals, plugs or gasketed plates. No venting is recommended as it may allow moist air in.

BUCKHORN
PUMPS, INC.

TECHNICAL DATA SHEET

T.D.S. NO.

4.2

PCN: _____

Supercedes PCN: _____

Date 03-10-06

- 4.1.1 Remove the wiper box seals and cap/plug the seal opening.
 - 4.1.2 Clean the pump outer surfaces prior to painting.
 - 4.1.3 If painting is required mask crank and lubricator shaft surfaces and keyways. If painting does not apply, go to Para. 4.1.8.
 - 4.1.4 Paint as specified by the customer order or as required.
 - 4.1.5 Apply a thin layer of grease to the exposed oil seal lips.
 - 4.1.6 Apply a thin layer of heavy rust preventative to the exposed crank and lubricator shaft surfaces and keyways.
 - 4.1.7 Wrap the exposed crank and lubricator shafts with waxed tape.
 - 4.1.8 Carefully wrap the following parts prior to placing them into polyurethane bags. Oil level gages, lube pressure gages, and breather caps.
 - 4.1.9 Finish box, crate and mark the parts from Para. 4.1.2 after final inspection (see Para. 4.2.2).
- 4.2 Shipping/Receiving (New Pumps Only)
- 4.2.1 All pumps and accessories (as applicable) will be final inspected by Kerr Pump personnel prior to shipping. Any witnessed or third party inspection will be signed-off by the purchaser or customer representative prior to final crating and shipment.
 - 4.2.2 Export crating will be performed by either an approved Kerr Pump source or as specified by the purchaser or customer. Any third party inspection will be coordinated with the source.
 - 4.2.3 Upon receipt of the shipment, the purchaser or customer is responsible for inspection and repair of damaged coatings at the expense of the shipper.

5.0 WARRANTY/START-UP

- 5.1 Pumps prepared per the above procedure qualify for the "Standard Terms & Conditions" in force on the date of shipment.
- 5.2 If the pump storage period is less than 6 months, follow the Short Term Pump Preparation Procedure.
- 5.3 Prior to start-up:
 - 5.3.1 Remove all storage caps, plugs, and covers.
 - 5.3.2 Replace any damaged or cracked O-rings or gaskets.
 - 5.3.3 Inspect power end shaft oil seals and replace if cracked, split or damaged.
 - 5.3.4 Install crankcase drain plug, lubrication level site glass and breather cap.
 - 5.3.5 Install, if applicable, any oil pressure and/or temperature gage.
 - 5.3.6 Check the connection of the plunger and pony rod to the crosshead prior to, and after, initial run-in of the pump.
 - 5.3.7 Fill the crankcase to the proper level with the specified lubricant.

BUCKHORN
PUMPS, INC.

TITLE: LONG TERM STORAGE PREPARATION PROCEDURE**1.0 SCOPE**

This procedure applies to Kerr Pumps ONLY. Storage procedures for any other unit components or accessories (gear reducers, engines, etc.) are to be prepared to the specific manufacture's recommendations.

1.1 Long-term storage is defined as storage and/or transient time exceeding six (6) months in an environment defined in Paragraph 2. If storage for less than six months is expected, the Short Term Pump Storage Preparation Procedure should be followed.

1.2 Kerr Pumps will only prepare for short term storage if so specified in the purchaser or customer order control document.

2.0 STORAGE ENVIRONMENT

A minimal environmental condition, to be met by the customer or purchaser, is a closed shelter to eliminate effects of sun, wind, sand or other debris. Large temperature and humidity changes should be avoided to prevent preventative deterioration or contamination by moisture.

3.0 RUST PREVENTATIVE PRODUCT

3.1 The recommended rust preservative should protect the internal power end parts from corrosion due to atmospheric moisture, and may be left in the pump when filled with appropriate lubricant and placed into service. The elevated temperature of service will cause rapid depletion of the preventative protection.

3.2 The following rust preventative products or their equivalents are recommended for use in Kerr Pumps and usually available in 5 gallon, 55 gallon containers:

CITGO: RUST-O-LINE OIL 10

SHELL: ENSIS OIL N

4.0 PROCEDURE

4.1 Preparation from; factory testing, inventory, or a distributor rebuild facility.

4.1.1 Drain any oil that may be in the power end and then fill the complete power end cavity with the specified rust preventative. After 15 to 20 minutes, drain the rust preventative back into its storage drum for future use.

4.1.2 Remove all plungers, pony rods (if applicable), baffle discs, packing and junk rings.

4.1.3 Remove and clean oil level gages, pressure gages and breather caps. Replace with pipe plugs in threaded openings.

TECHNICAL DATA SHEET

T.D.S. NO. 4.3

PCN: _____

Supercedes PCN: _____

Date 03-10-06

- 4.1.4 All breathers shall be replaced with airtight seals, plugs or gasketed plates. No venting is recommended as it may allow moist air in.
 - 4.1.5 Remove the wiper box seals and cap/plug the seal opening.
 - 4.1.6 Clean the pump outer surfaces prior to painting.
 - 4.1.7 If painting is required mask crank and lubricator shaft surfaces and keyways. If painting does not apply, go to Para. 4.1.9.
 - 4.1.8 Paint as specified by the customer order or as required.
 - 4.1.9 Apply a thin layer of grease to the exposed oil seal lips.
 - 4.1.10 Apply a thin layer of heavy rust preventative to the exposed crank and lubricator shaft surfaces and keyways.
 - 4.1.11 Wrap the exposed crank and lubricator shafts with waxed tape.
 - 4.1.12 Carefully wrap the following parts prior to placing them into polyurethane bags. Oil level gages, lube pressure gages, and breather caps.
 - 4.1.13 Finish box, crate and mark the parts from Para. 4.1.10 after final inspection (see Para. 4.2.2).
- 4.2 Shipping/Receiving (New Pumps Only)
- 4.2.1 All pumps and accessories (as applicable) will be final inspected by Kerr Pump personnel prior to shipping. Any witnessed or third party inspection will be signed-off by the purchaser or customer representative prior to final crating and shipment.
 - 4.2.2 Export crating will be performed by either an approved Kerr Pump source or as specified by the purchaser or customer. Any third party inspection will be coordinated with the source.
 - 4.2.3 Upon receipt of the shipment, the purchaser or customer is responsible for inspection and repair of damaged coatings at the expense of the shipper.

5.0 WARRANTY / START-UP

- 5.1 Pumps prepared per the above procedure qualify for the "Standard Terms & Conditions" in force on the date of shipment.
- 5.2 If the pump storage period will exceed 6 months, follow the Long-Term Pump Preparation Procedure.
- 5.3 Prior to start-up:
 - 5.3.1 Remove all storage caps, plugs, and covers.
 - 5.3.2 Install the packing, junk rings, plungers, pony rods (if applicable), baffle discs, and wiper box seals. Replace any damaged or cracked O-rings or gaskets.
 - 5.3.3 Inspect power end shaft oil seals and replace if cracked, split or damaged.
 - 5.3.4 Install crankcase drain plug, lubrication level site glass and breather cap.
 - 5.3.5 Install, if applicable, any oil pressure and/or temperature gage.
 - 5.3.6 Check the connection of the plunger and pony rod to the crosshead prior to, and after, initial run-in of the pump.
 - 5.3.7 Fill the crankcase to the proper level with the specified lubricant.

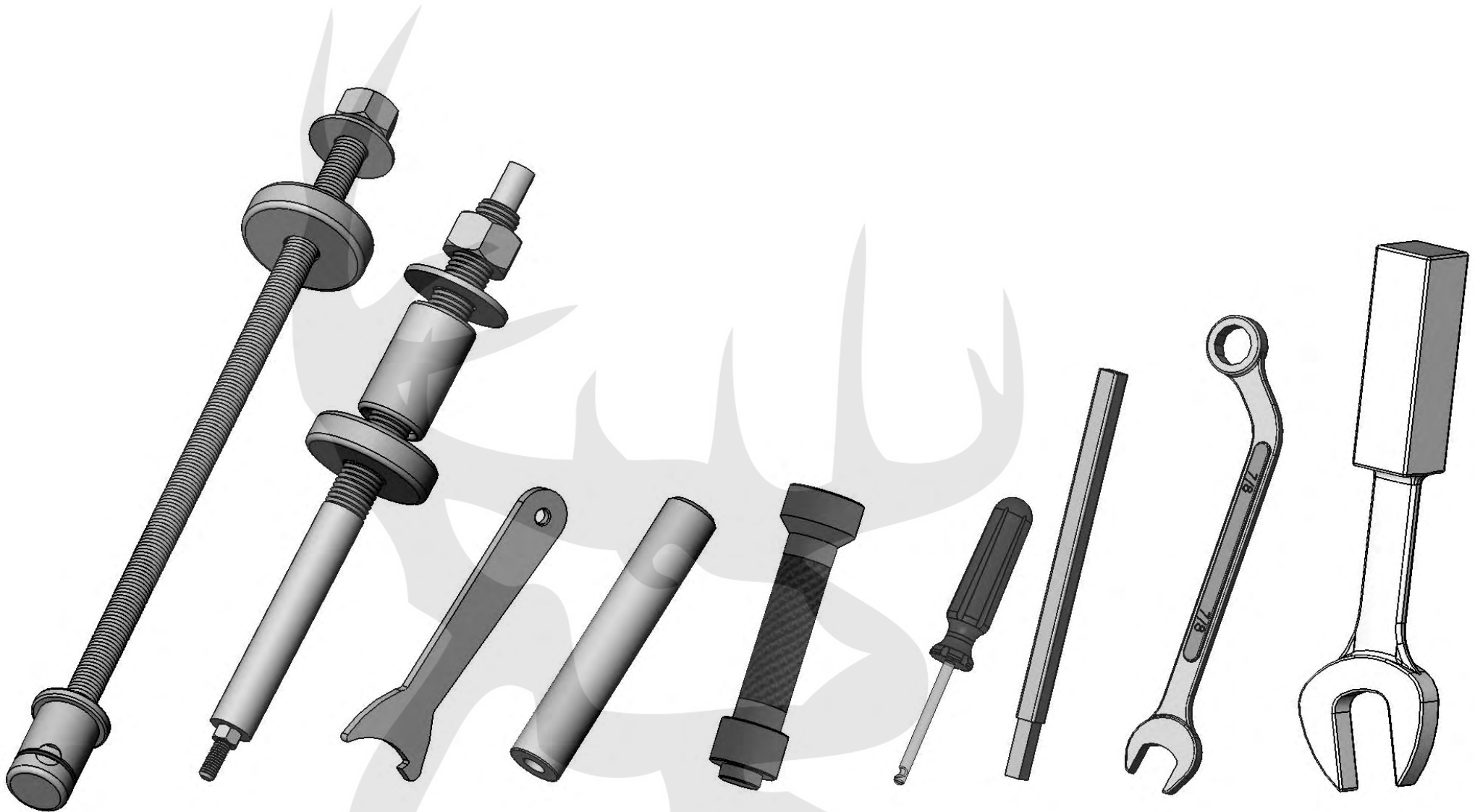

KM-76M
WING-
GUIDED
SEAT
TRI-PIN
TYPE
PULLER
ASS'Y

KM-77
DISC
SEAT
STEM
TYPE
PULLER
ASS'Y

KM-91
SCREWED TYPE
STUFFING BOX
WRENCH

KM-306
VALVE SEAT
SEATING TOOL

KM-276
PONY ROD
SEAL TOOL

AP-71T
VALVE
INSERT
TOOL

AP-425
STUFFING
BOX NUT
WRENCH

KM-75
BOLTED TYPE
STUFFING BOX
WRENCH

KM-277
PONY
ROD
WRENCH

SPECIAL TOOLS

FOR KD-1250, KD-2250, KJ-2250, KJ-2250BC, KM-3250, KM-3300

BUCKHORN
PUMPS, INC.

How To Put Inserts In Valves Using Kerr Valve Insert Tool



1) Push Valve Insert over valve legs. Hint: (Insert will be more pliable if heated first-- warm to the touch not hot).



2) Put Tool between valve and valve insert with groove against valve.



3) Holding Valve insert down with thumb.



4) While holding valve down with thumb, rotate around valve with tool. (Similar to mounting a tire on a rim).



5) Continue rotating around valve with tool until insert is completely in groove.

INSTRUCTIONS FOR CHANGING DISC VALVES (Revision B)

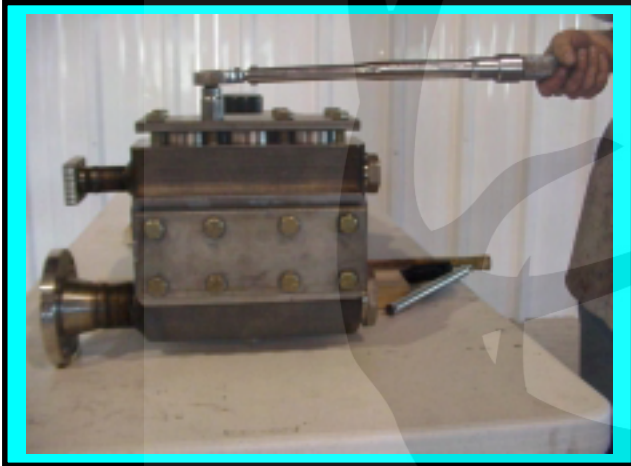

1. Remove Capscrews from Top and End Cover Plates

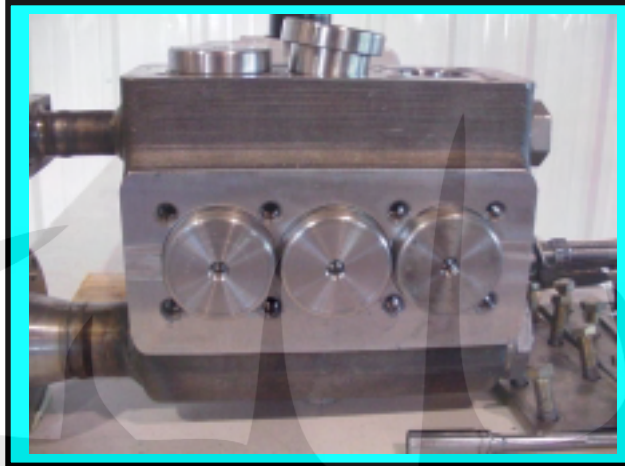

2. Remove Round Cover Caps; inspect o'rings for damage;

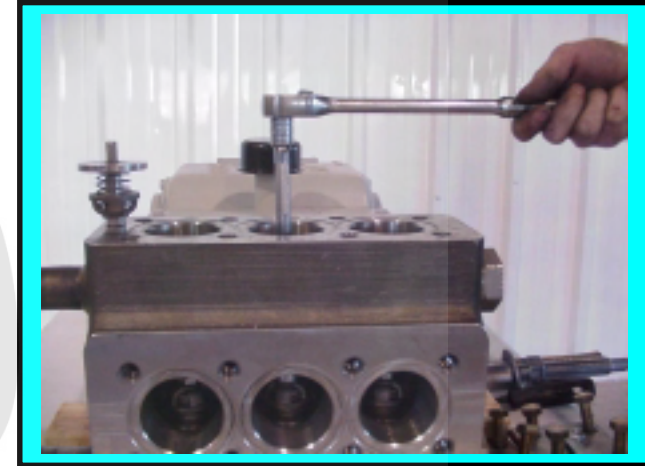

3. Unscrew Valve Capscrew; Remove Capscrew, Spring Retainer, Spring, Spacer, and Disc

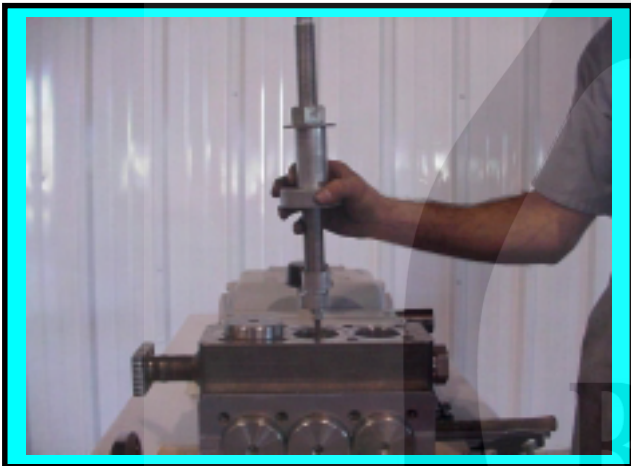

4. Screw Kerr Pump Valve Puller into seat approximately $\frac{3}{4}$ "



5. Hold Puller Stem from turning; Rotate large nut until seat releases



6. Remove Valve Seat from Puller; Remove remaining valves

INSTRUCTIONS FOR CHANGING DISC VALVES (Revision B) (cont.)

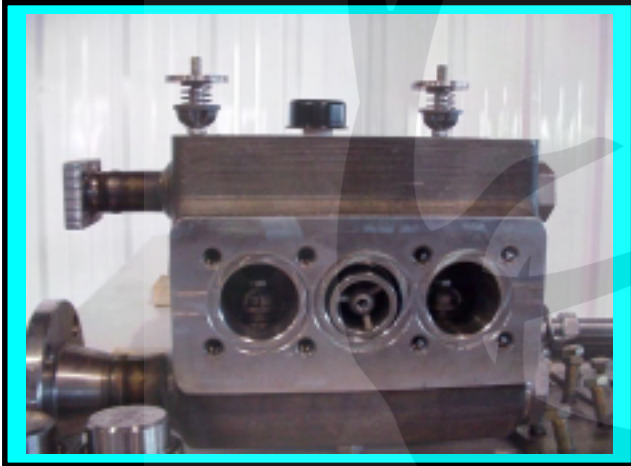

7. Remove Suction Valve Seat Through End Port



8. To Install Valve Assembly; Insert through End Port

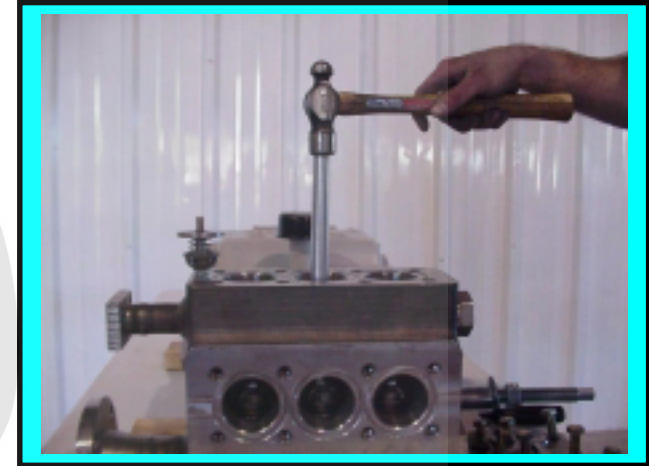

9. Use a 1" wooden dowel rod to drive valve seat assembly into seating area using several firm but, not heavy blows with a hammer; CAUTION: heavy blows will damage valve

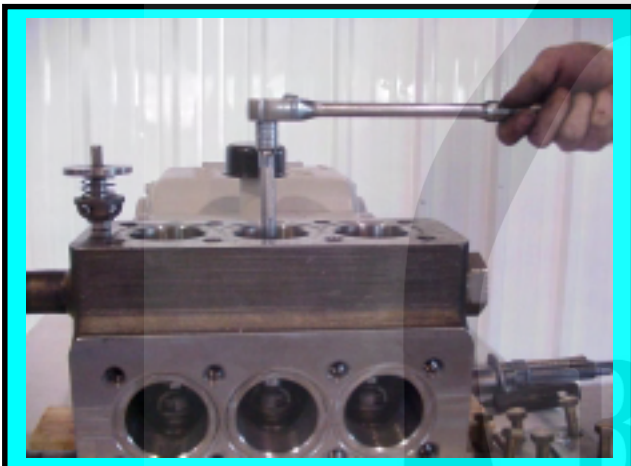

10. Torque valve capscrew to Kerr Pump specs



11. Install Discharge Valve, following procedure 9.



12. Install Cover Caps and torque Cover Plate capscrews to Kerr Pump Specs

INSTRUCTIONS FOR CHANGING WING/GUIDED VALVES

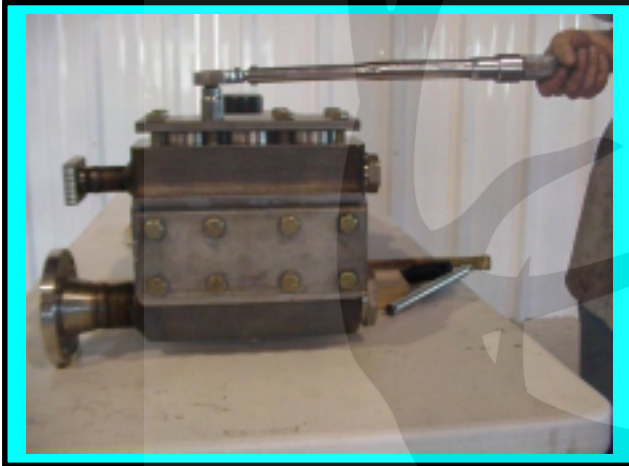

1. Remove Capscrews from Top and End Cover Plates

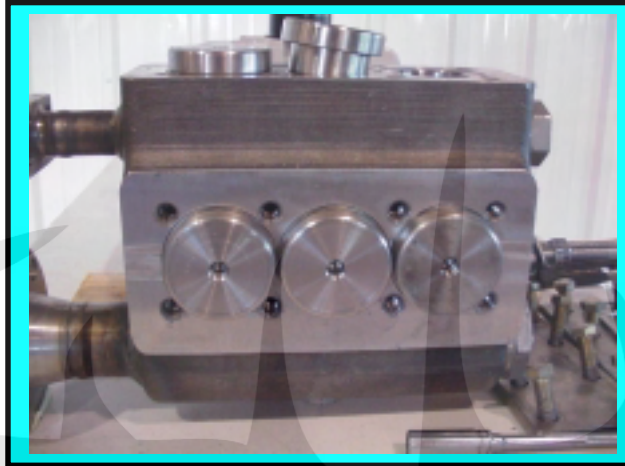

2. Remove Round Cover Caps; inspect o'rings for damage;

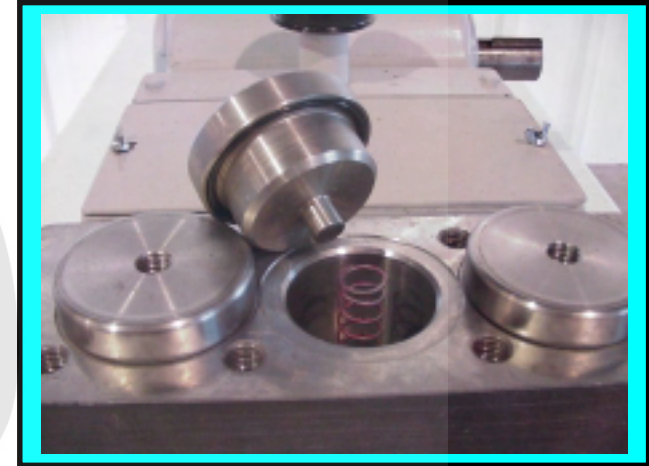

3. Remove Discharge Spring and Discharge Valve

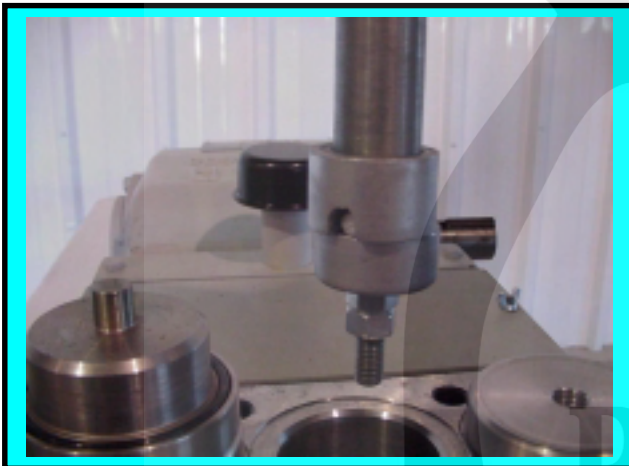

4. Insert Kerr Valve Seat Puller through valve seat with eccentric offset to engage valve seat. NOTE: Puller stud may be removed when pulling wing/guided valve seats.

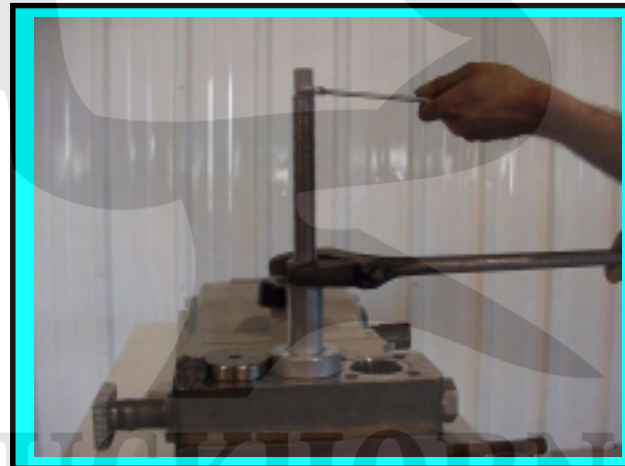

5. Hold Puller Stem from turning; Rotate large nut until seat releases

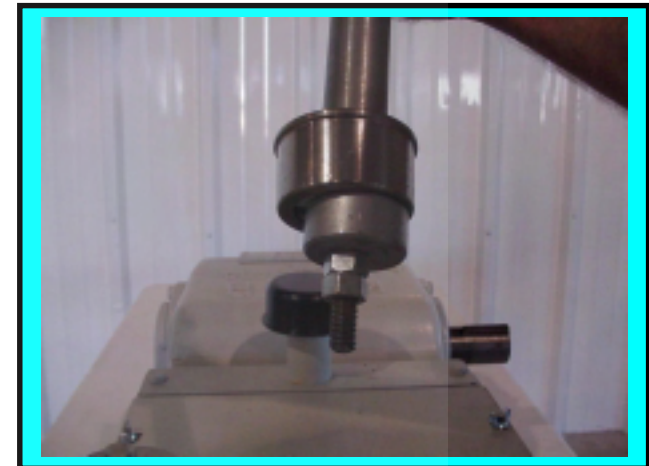

6. Remove Valve Seat from Puller; Spacer on Puller may need to be removed when pulling Suction Valve Seats; Remove remaining valves

INSTRUCTIONS FOR CHANGING WING/GUIDED VALVES (cont.)

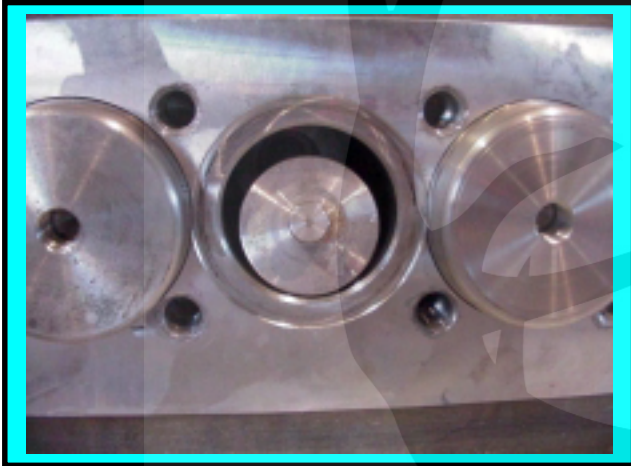

7. Remove Suction Valves, springs, and seats through End Port

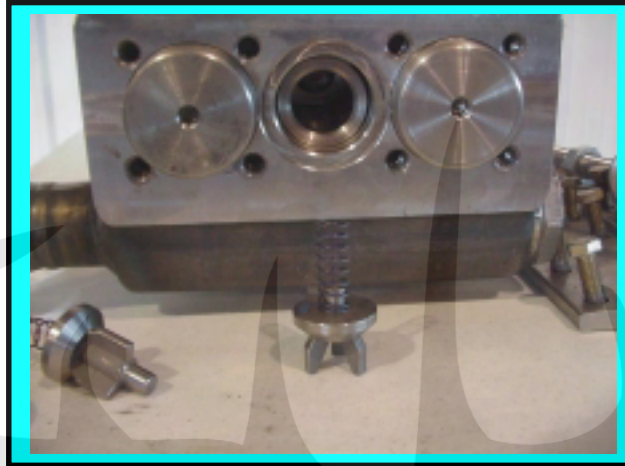

8. To Install Suction Valve & Seat, insert Valve Seat and Valve Body through End Port

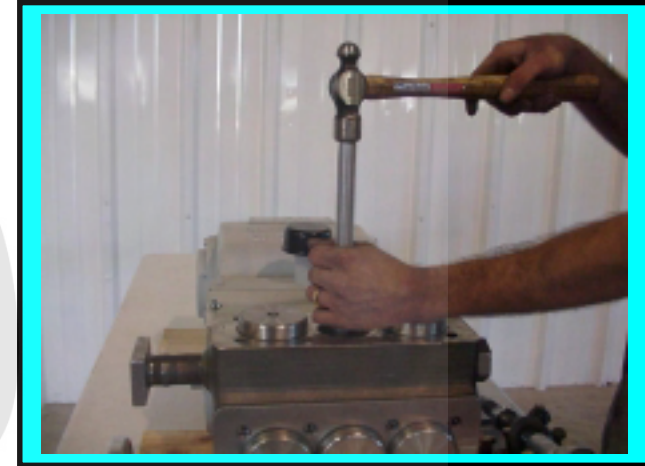

9. Use metal rod to drive valve seat assembly into seating area using several firm but, not heavy blows with a hammer

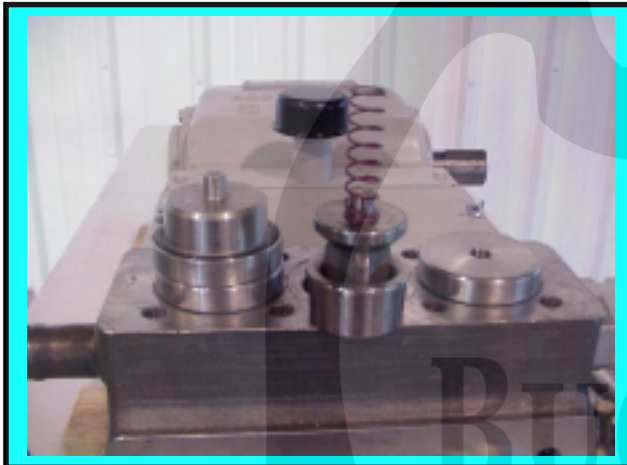

10. Install Discharge Valves after Suction Valves have been installed, always be sure short springs are on Suction Valve and Long Spring on Discharge Valves



11. Install Cover Caps and torque Cover Plate capscrews to Kerr Pump Specs

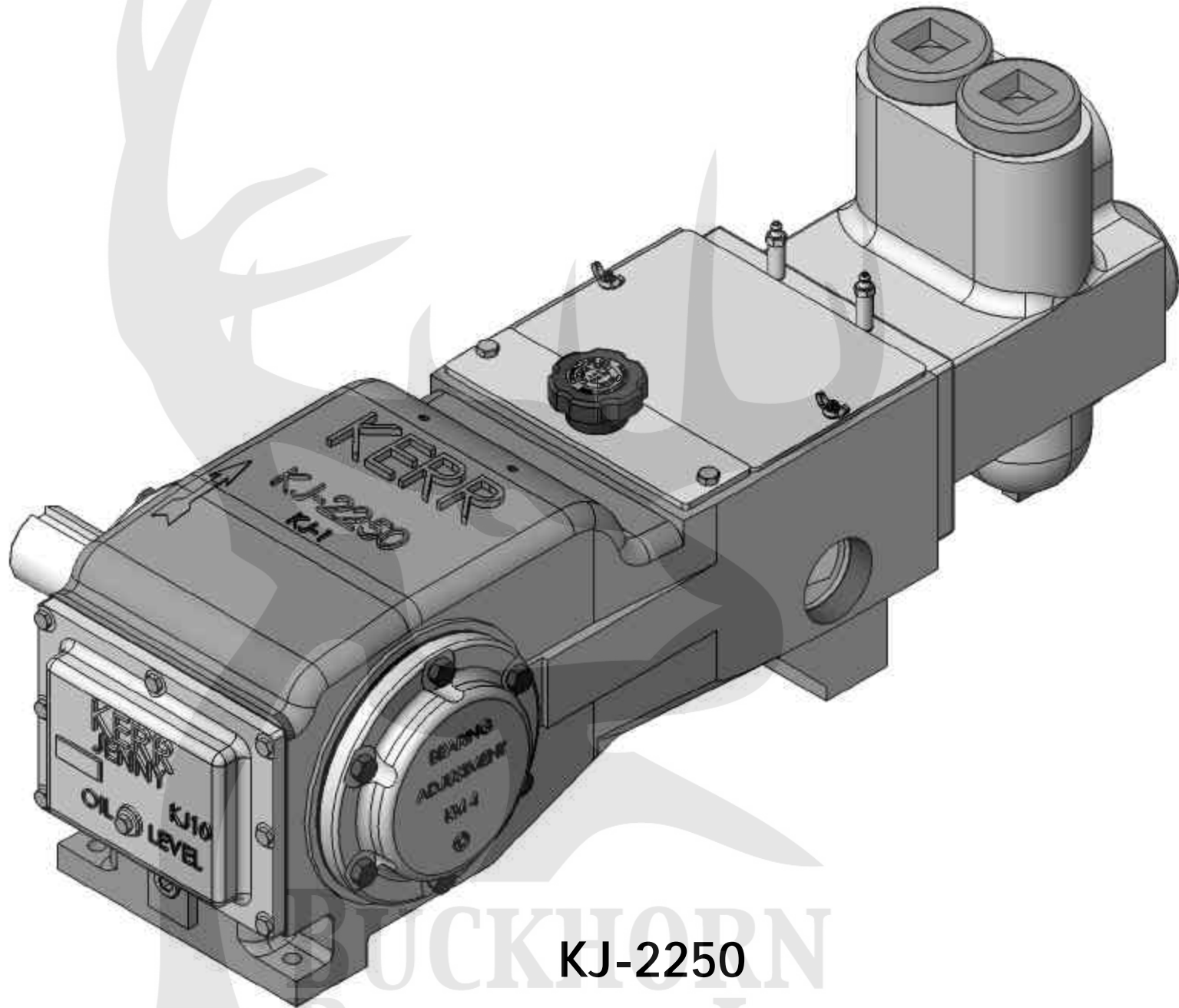

KJ-2250

**BUCKHORN
PUMPS, INC.**

KJ-2250 PLUNGER TYPE PUMP TORQUE SPECIFICATIONS

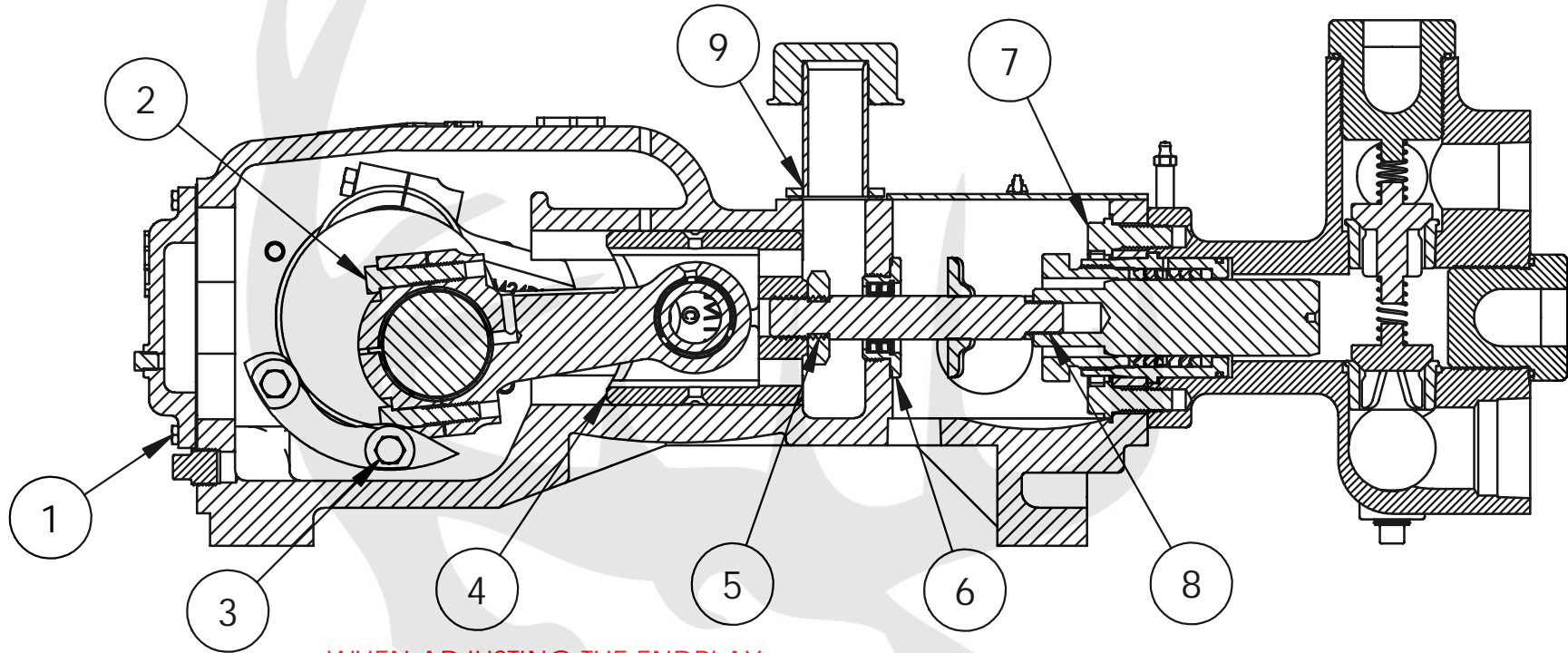

WHEN ADJUSTING THE ENDPLAY OF THE TAPERED ROLLER BEARINGS USED ON THE CRANKSHAFT, DIAL INDICATORS AND SHIMS MUST BE PROPERLY USED. INCORRECT BEARING ADJUSTMENT MAY RESULT IN EXCESSIVE NOISE, TEMPERATURE, AND REDUCED BEARING LIFE. Kerr Pumps RECOMMENDS BETWEEN .000" - .005" OF INTERNAL AXIAL CLEARANCE (END PLAY OR SIDE TO SIDE) WHEN ASSEMBLED. FINAL ADJUSTMENT MUST BE MADE USING A DIAL INDICATOR.

INSURE THE CONNECTING RODS ARE DISCONNECTED TO ALLOW FREE CRANKSHAFT MOTION.

*TORQUE SPECIFICATIONS

REFERENCE	DESCRIPTION	TORQUE
1	PAN COVER CAPSCREW	9 ft-lb (12 Nm)
2	CONNECTING ROD CAPSCREW	65 ft-lb (88 Nm)
3	BEARING HOUSING CAPSCREW	50 ft-lb (68 Nm)
4	WRIST PIN SET SCREW AND JAM NUT	12 ft-lb (16 Nm)
5	PONY ROD	500 ft-lb (678 Nm)
6	PONY ROD PACKING GLAND	50 ft-lb (68 Nm)
7	FLUID END CAP SCREW	90 ft-lb (122 Nm)
8	PLUNGER TO PONY ROD	300 ft-lb (407 Nm)
9	CROSSHEAD COVER PLATE CAPSCREW	10 ft-lb (14 Nm)

NOTE: WHEN USING LUBRICANTS, REDUCE TORQUE AS FOLLOWS;

LUBRICANT	PERCENTAGE OF TORQUE REDUCTION REQUIRED
OIL & GREASE	REDUCE TORQUE 40%
ANTI - SEIZE COMPOUND	REDUCE TORQUE 45%

.000"-.005" SHAFT END PLAY
 .003"-.004" CONNECTING ROD AT CRANKSHAFT
 .001" .002" CONNECTING ROD AT WRIST PIN

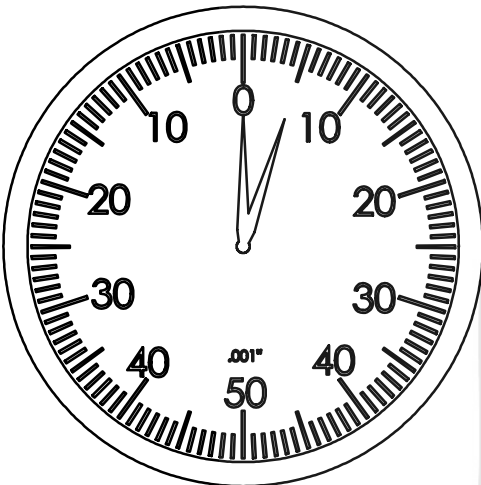

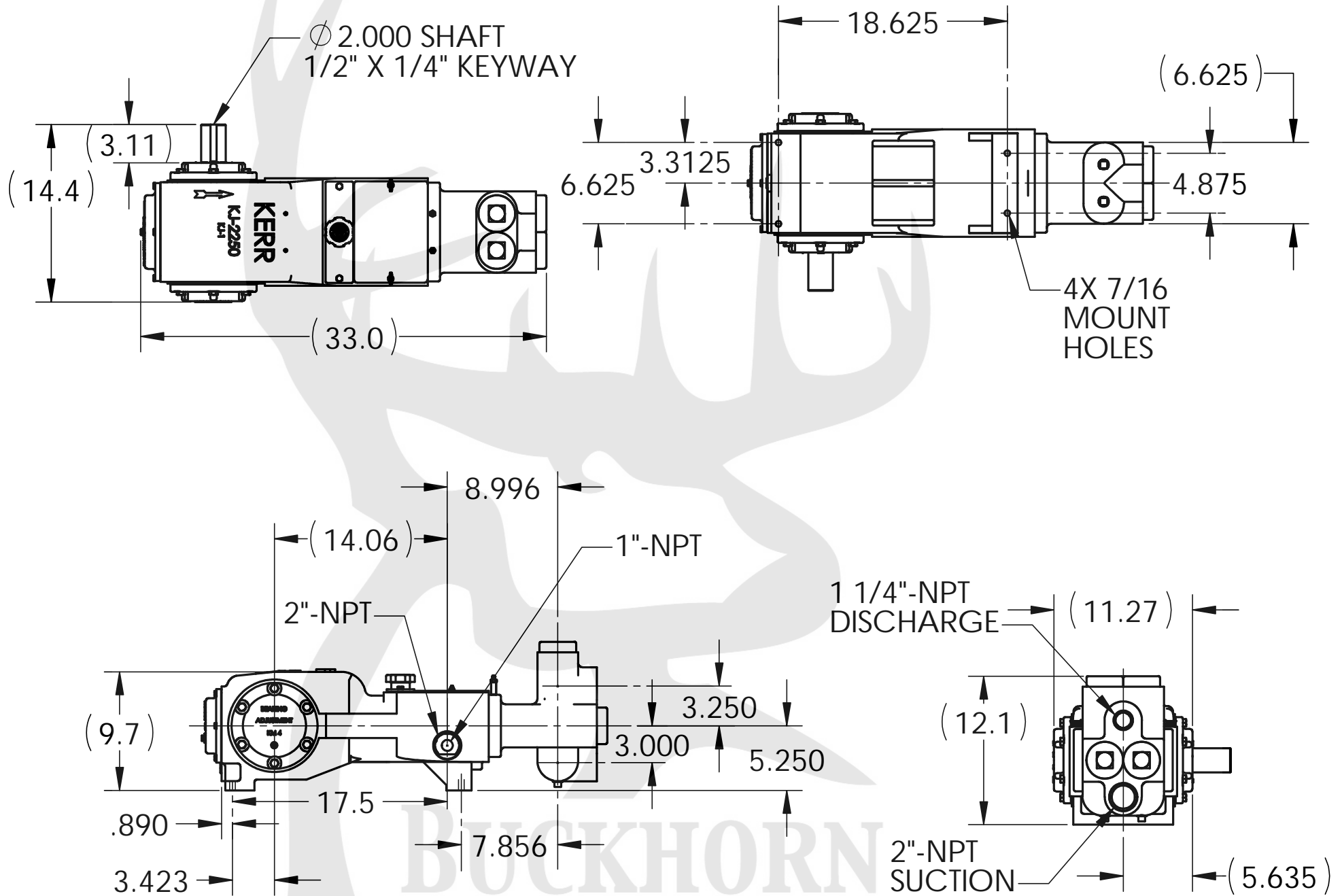

GENERAL DIMENSIONS FOR KJ-2250

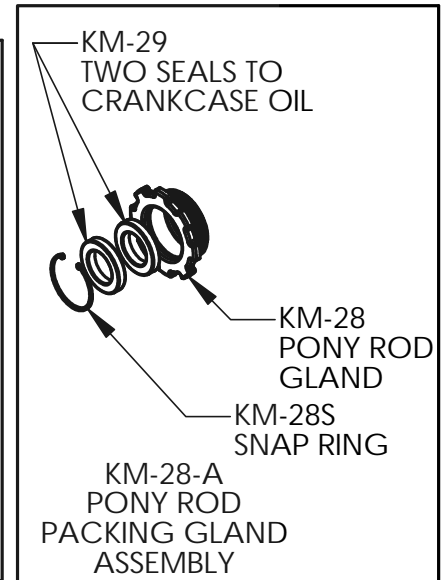
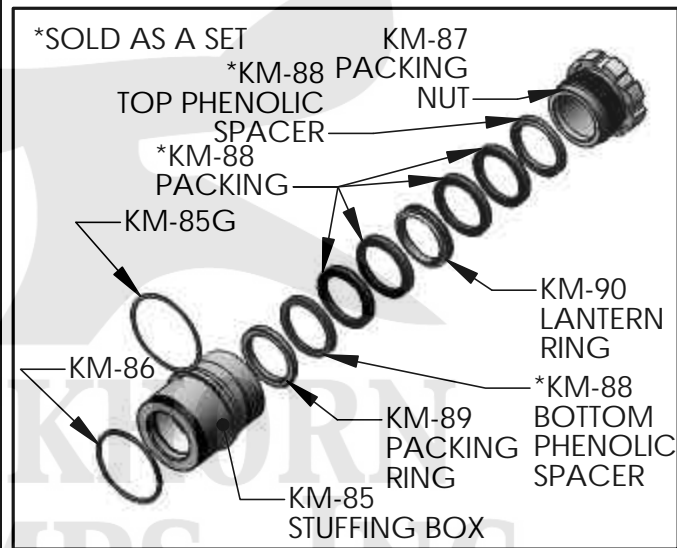
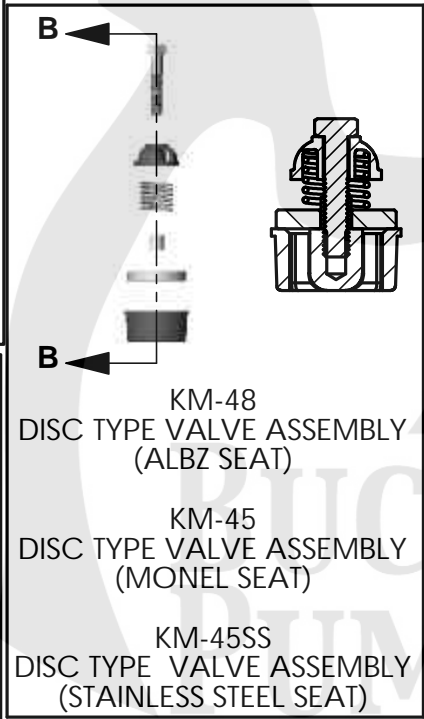
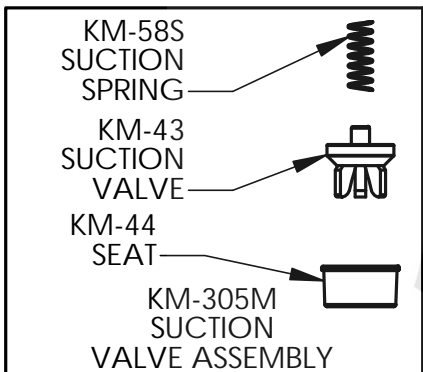
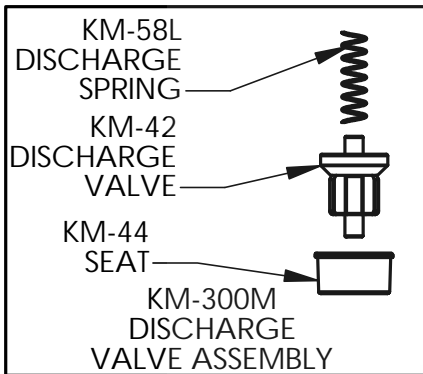
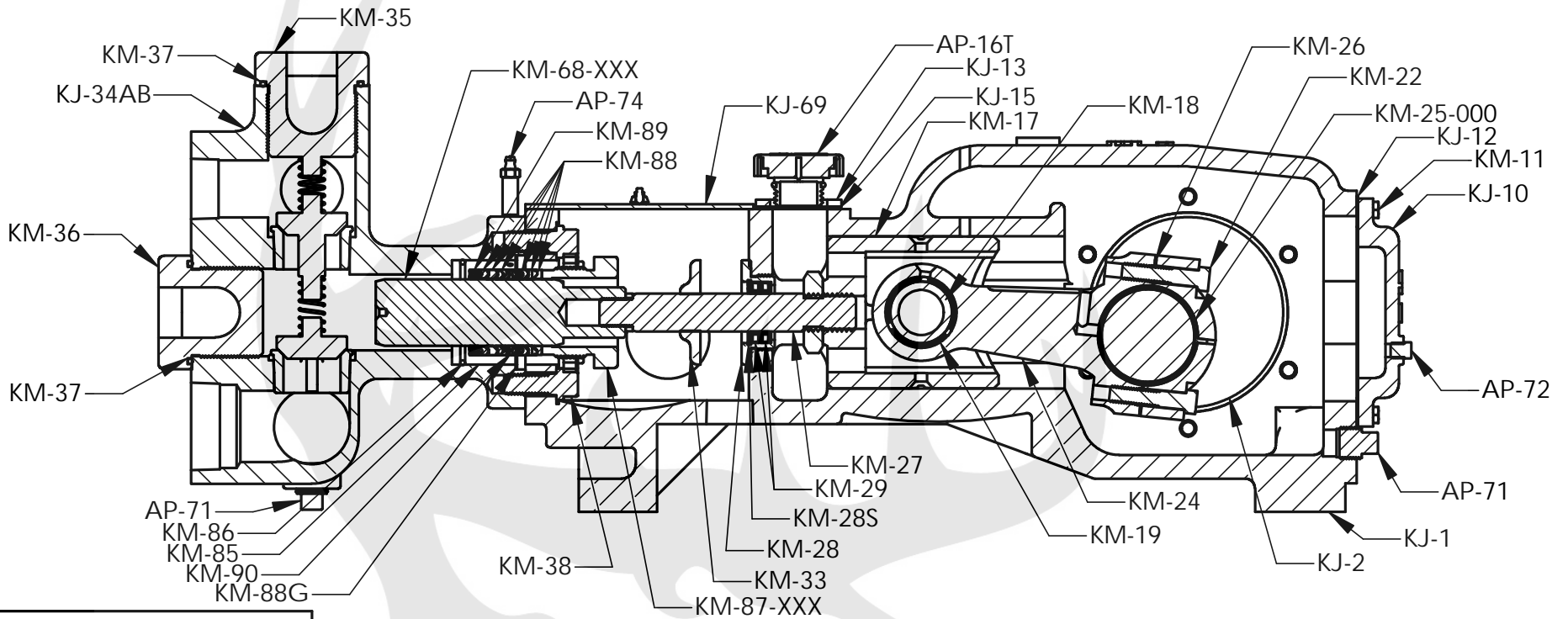

KJ-2250

Kerr KJ-2250/KJ-2250BC Plunger Type Pump

Part Number	Description	# Req
KM-SP1R	Spacer, Rear Long Top Mount	2
KM-SP1F	Spacer, Front Short Top Mount	2
KJ-1	Pump Case	1
KJ-2	Crankshaft - Heat Treated	1
KM-3	Crankshaft Oil Seal	1
KM-4	Bearing Housing (Blind Side)	1
KM-5	Bearing Housing (Shaft Side)	1
KM-6	Bearing Housing Capscrews	12
KM-7	Bearing Housing Gaskets	2
KM-8-005	Main Bearing Adjusting Shims .005	As Req.
KM-8-010	Main Bearing Adjusting Shims .010	As Req.
KM-8-015	Main Bearing Adjusting Shims .015	As Req.
KM-9	Main Bearings	2
KJ-10	Pan Cover	1
KM-11	Pan Cover Capscrews	8
KJ-12	Pan Cover Gasket	1
KJ-13	Crosshead Cover Plate	1
KD-13T	Crosshead Cover Plate Theaded	1
KJ-13T	Crosshead Cover Plate Theaded	1
KM-14	Cover Plate Capscrews	2
KJ-15	Crosshead Cover Plate Gasket	1
AP-16	Breather Cap (Oil Filler)	1
AP-16T	Breather Cap (Oil Filler) Threaded Style	1
KJ-16D	Oil Level Dip Stick	1
KM-17	Crosshead	2
KM-18	Wrist Pin	2
KM-19	Wrist Pin Bushing	2
KM-20	Wrist Pin Set Screws & Nut	2
KM-21	Coverplate Capscrew	12
KM-22	Connecting Rod Capscrew	4
KM-24	Connecting Rod Only (No Inserts - Requires inserts both ends)	2
KM-24A	Connecting Rod (Inserted Both Ends)	2
KM-25-000	Connecting Rod Insert Bearing (Std)	2
KM-25-015	Connecting Rod Insert Bearing (.015)	2
KM-25-030	Connecting Rod Insert Bearing (.030)	2

Kerr KJ-2250/KJ-2250BC Plunger Type Pump

Part Number	Description	# Req
KM-25-045	Connecting Rod Insert Bearing (.045)	2
KM-25-060	Connecting Rod Insert Bearing (.060)	2
KM-26	Connecting Rod Shims (Laminated)	4
KM-27	Pony Rod with Jam Nut Installed	2
KM-27C	Pony Rod for 5/8, 3/4, 7/8, 1 Ceramic Plunger	2
KM-28	Pony Rod Gland for Double Seal	2
KM-28S	Pony Rod Gland Snap Ring	2
KM-28A	Pony Rod Gland Assy (KM-28, KM-28S, 2ea of KM-29)	2
KM-29	Pony Rod Oil Seal (Req. 2 per Set)	2 sets
KM-30	Pony Rod Wiper Ring (Fiber)	2
KJ-31	Top and End Cover Cap Plate for BC Cover Caps	2
KM-32	Plunger Washer Use With 1 & 1 1/4 (3/4 Female Thread)	2
KM-32C	Pony Rod Washer (Use With Pony Rod KM-27C)	2
KM-33	Pony Rod Splash Guard	2
KJ-34BCAB	Fluid End (ALBZ) Vessel Only	1
KJ-34S	Fluid End (Steel) Vessel Only	1
KJ-34SS	Fluid End (Stainless Steel) Vessel Only	1
KJ-34BC	Fluid End (ALBZ) (Bolted Cap) Vessel Only	1
KJ-34BCS	Fluid End (Steel) (Bolted Cap) Vessel Only	1
KJ-34BCSS	Fluid End (Stainless Steel) (Bolted Cap) Vessel Only	1
KJ-34BCFSOS	Fluid End (Forged Steel) (Bolted Cap) Vessel W/Flanges	1
KJ-34BCFSSOS	Fluid End (Forged Stainless Steel)(Bolted Cap) Vessel W/Flanges	1
KM-35AB	Top Cover Cap (ALBZ)	2
KM-35D	Top Cover Cap (Ductile)	2
KM-35S	Top Cover Cap (Steel)	2
KM-35SS	Top Cover Cap (Stainless Steel)	2
KM-35BCAB	Top Cover Cap (Bolted Cap) (ALBZ)	2
KM-35BCD	Top Cover Cap (Bolted Cap) (Ductile)	2
KM-35BCS	Top Cover Cap (Bolted Cap) (Steel)	2
KM-35BCSS	Top Cover Cap (Bolted Cap) (Stainless Steel)	2
KM-36AB	End Cover Cap (ALBZ)	2
KM-36D	End Cover Cap (Ductile)	2
KM-36S	End Cover Cap (Steel)	2
KM-36SS	End Cover Cap (Stainless Steel)	2
KM-36BCAB	End Cover Cap (Bolted Cap) (ALBZ)	2

BUCKHORN
PUMPS, INC.

Kerr KJ-2250/KJ-2250BC Plunger Type Pump

Part Number	Description	# Req
KM-36BCD	End Cover Cap (Bolted Cap) (Ductile)	2
KM-36BCS	End Cover Cap (Bolted Cap) (Steel)	2
KM-36BCSS	End Cover Cap (Bolted Cap) (Stainless Steel)	2
CP-37-875AB	Packing Ring 7/8 (AB)	2
CP-37-100AB	Packing Ring 1 (AB)	2
CP-37-125AB	Packing Ring 1 1/4 (AB)	2
CP-37-875S	Packing Ring 7/8 (Steel)	2
CP-37-100S	Packing Ring 1 (Steel)	2
CP-37-125S	Packing Ring 1 1/4 (Steel)	2
CP-37-875SS	Packing Ring 7/8 (Stainless Steel)	2
CP-37-100SS	Packing Ring 1 (Stainless Steel)	2
CP-37-125SS	Packing Ring 1 1/4 (Stainless Steel)	2
KM-37N	O-Ring,Stuffing Box & Cover Cap	3
KM-37N	O-Ring Stuffing Box & Cover Cap	6
KM-38	Fluid End Capscrews	6
KM-39	Discharge Valve (ALBZ)	2
KM-40	Suction Valve (ALBZ)	2
KM-41	Valve Seats (ALBZ)	4
KM-42	Discharge Valve (Monel)	2
KM-43	Suction Valve (Monel)	2
KM-44	Valve Seats (Monel)	4
KM-45	Delrin Valve Complete with Monel Seat	4
KM-45SS	Delrin Valve Complete with Stainless Steel Seat	4
KM-45SS-SS	Stainless Steel Disc Valve Complete with Stainless Steel Seat	4
KM-45T-M	Titanium Disc Valve Complete with Monel Seat	4
KM-45T-SS	Titanium Disc Valve Complete with Stainless Steel Seat	4
KM-47	Valve Seat Monel Disc Type	1 per valv
KM-47SS	Valve Seat Stainless Steel Disc Type	1 per valv
KM-48	Delrin Valve Complete with ALBZ Seat	4
KM-49	Capscrew Disc Type Valve	1 per valv
KM-50	Spring Retainer Disc Type	1 per valv
KM-51	Spring Disc Type	1 per valv
KM-52	Sleeve Spacer Disc Type	1 per valv
KM-53	Delrin Disc	1 per valv
KM-53SS	Stainless Steel Disc	1 per valv

BUCKHORN
PUMPS, INC.

Kerr KJ-2250/KJ-2250BC Plunger Type Pump

Part Number	Description	# Req
KM-53T	Titanium Disc	1 per valv
KM-54	Valve Seat ALBZ Disc Type	1 per valv
KM-55	Discharge Valve (Stainless Steel)	2
KM-56	Suction Valve (Stainless Steel)	2
KM-57	Valve Seat (Stainless Steel)	4
CP-58V-0805-625	805 Pressure Rings Only 5/8" (3 Ea. Per Set)	2 sets
CP-58V-0805-075	805 Pressure Rings 3/4" (3 Ea. Per set)	2 sets
CP-58V-0805-875	805 Pressure Rings Only 7/8"(3 Ea. Per Set)	2 sets
CP-58V-0805-100	805 Pressure Rings Only 1"(3 Ea. Per Set)	2 sets
CP-58V-0805-125	805 Pressure Rings Only 1 1/4 (3 Ea. Per Set)	2 sets
CP-58V-0758-625	758 Pressure Rings Only 5/8" (3 Ea. Per Set)	2 sets
CP-58V-0758-075	758 Pressure Rings 3/4" (3 Ea. Per Set)	2 sets
CP-58V-0758-875	758 Pressure Rings Only 7/8" (3 Ea. Per Set)	2 sets
CP-58V-0758-100	758 Pressure Rings Only 1" (3 Ea. Per Set)	2 sets
CP-58V-0758-125	758 Pressure Rings Only 1 1/4" (3 Ea. Per Set)	2 sets
CP-58VPK-0758-625	758/PK Pressure Ring Only 5/8"(3 Ea. Per Set)	2 sets
CP-58VPK-0758-750	758/PK Pressure Ring Only 3/4" (3 Ea. Per Set)	2 sets
CP-58VPK-0758-875	758/PK Pressure Ring Only 7/8 (3 Ea..Per Set)	2 sets
CP-58VPK-0758-100	758/PK Pressure Ring Set Only (3 Ea. Per Set)	2 sets
CP-58VPK-0758-125	758/PK Pressure Ring Set Only 1 1/4" (3 Ea. Per Set)	2 sets
KM-58L	Valve Spring (Wing-Guided) (Long) (Discharge)	2
KM-58S	Valve Spring (Wing-Guided) (Short) (Suction)	2
CP-59	Packing Spring (for Spring Loaded Packing) 7/8, 1, 1 1/4	2
CP-59-625	Packing Spring (for Spring Loaded Packing) 5/8	2
CP-59-750	Packing Spring (for Spring Loaded Packing) 3/4	2
KM-59-200AB	Packing Gland 2 (Bolted Type) (ALBZ)	2
KM-59-200S	Packing Gland 2 (Bolted Type) (Steel)	2
KM-59-200SS	Packing Gland 2 (Bolted Type) (Stainless Steel)	2
KM-59A-125AB	Stuffing Box Gland Adapter 1 1/4 (ALBZ)	2
KM-59A-150AB	Stuffing Box Gland Adapter 1 1/2 (ALBZ)	2
KM-59A-175AB	Stuffing Box Gland Adapter 1 3/4 (ALBZ)	2
KM-59A-125S	Stuffing Box Gland Adapter 1 1/4 (Steel)	2
KM-59A-150S	Stuffing Box Gland Adapter 1 1/2 (Steel)	2
KM-59A-175S	Stuffing Box Gland Adapter 1 3/4 (Steel)	2
KM-59A-125SS	Stuffing Box Gland Adapter 1 1/4 (Stainless Steel)	2

Kerr KJ-2250/KJ-2250BC Plunger Type Pump

Part Number	Description	# Req
KM-59A-150SS	Stuffing Box Gland Adapter 1 1/2 (Stainless Steel)	2
KM-59A-175SS	Stuffing Box Gland Adapter 1 3/4 (Stainless Steel)	2
KM-60-100AB	Packing Ring 1 (ALBZ)	2
KM-60-125AB	Packing Ring 1 1/4 (ALBZ)	2
KM-60-150AB	Packing Ring 1 1/2 (ALBZ)	2
KM-60-175AB	Packing Ring 1 3/4 (ALBZ)	2
KM-60-200AB	Packing Ring 2 (ALBZ)	2
KM-60-100S	Packing Ring 1 (Steel)	2
KM-60-125S	Packing Ring 1 1/4 (Steel)	2
KM-60-150S	Packing Ring 1 1/2 (Steel)	2
KM-60-175S	Packing Ring 1 3/4 (Steel)	2
KM-60-200S	Packing Ring 2 (Steel)	2
KM-60-100SS	Packing Ring 1 (Stainless Steel)	2
KM-60-125SS	Packing Ring 1 1/4 (Stainless Steel)	2
KM-60-150SS	Packing Ring 1 1/2 (Stainless Steel)	2
KM-60-175SS	Packing Ring 1 3/4 (Stainless Steel)	2
KM-60-200SS	Packing Ring 2 (Stainless Steel)	2
KM-61-100AB	Packing Lantern Ring (For Mechanical Lubrication) 1 (AB)	2
KM-61-125AB	Packing Lantern Ring (For Mechanical Lubrication) 1 1/4 (AB)	2
KM-61-150AB	Packing Lantern Ring (For Mechanical Lubrication) 1 1/2 (AB)	2
KM-61-175AB	Packing Lantern Ring (For Mechanical Lubrication) 1 3/4 (AB)	2
KM-61-200AB	Packing Lantern Ring (For Mechanical Lubrication) 2 (AB)	2
KM-61-100S	Packing Lantern Ring (For Mechanical Lubrication) 1 (Steel)	2
KM-61-125S	Packing Lantern Ring (For Mechanical Lubrication) 1 1/4 (Steel)	2
KM-61-150S	Packing Lantern Ring (For Mechanical Lubrication) 1 1/2 (Steel)	2
KM-61-175S	Packing Lantern Ring (For Mechanical Lubrication) 1 3/4 (Steel)	2
KM-61-200S	Packing Lantern Ring (For Mechanical Lubrication) 2 (Steel)	2
KM-61-100SS	Packing Lantern Ring (For Mechanical Lubrication) 1 (Stainless Steel)	2
KM-61-125SS	Packing Lantern Ring (For Mechanical Lubrication) 1 1/4 (Stainless Steel)	2
KM-61-150SS	Packing Lantern Ring (For Mechanical Lubrication) 1 1/2 (Stainless Steel)	2
KM-61-175SS	Packing Lantern Ring (For Mechanical Lubrication) 1 3/4 (Stainless Steel)	2
KM-61-200SS	Packing Lantern Ring (For Mechanical Lubrication) 2 Stainless (Steel)	2
KM-63-100	838 Plunger Packing (Non Adjustable) 1	2 sets
KM-63-125	838 Plunger Packing (Non Adjustable) 1 1/4	2 sets
KM-63-150	838 Plunger Packing (Non Adjustable) 1 1/2	2 sets

Kerr KJ-2250/KJ-2250BC Plunger Type Pump

Part Number	Description	# Req
KM-63-175	838 Plunger Packing (Non Adjustable) 1 3/4	2 sets
KM-63-200	838 Plunger Packing (Non Adjustable) 2	2 sets
KM-63G-100	858 Plunger Packing (Non Adjustable) 1	2 sets
KM-63G-125	858 Plunger Packing (Non Adjustable) 1 1/4	2 sets
KM-63G-150	858 Plunger Packing (Non Adjustable) 1 1/2	2 sets
KM-63G-175	858 Plunger Packing (Non Adjustable) 1 3/4	2 sets
KM-63G-200	858 Plunger Packing (Non Adjustable) 2	2 sets
KM-63K-100	Kevlar Packing 1	2 sets
KM-63K-125	Kevlar Packing 1 1/4	2 sets
KM-63K-150	Kevlar Packing 1 1/2	2 sets
KM-63K-175	Kevlar Packing 1 3/4	2 sets
KM-63K-200	Kevlar Packing 2	2 sets
KM-63PK-200	Peak Packing 2	2 sets
KM-63T-100	Teflon Packing 1	2 sets
KM-63T-125	Teflon Packing 1 1/4	2 sets
KM-63T-150	Teflon Packing 1 1/2	2 sets
KM-63T-175	Teflon Packing 1 3/4	2 sets
KM-63T-200	Teflon Packing 2	2 sets
KM-64	Packing Gland Stud	4
KM-65	Packing Gland Stud Nut	4
KM-65L	Stuffing Box Lock Nut (Stainless Steel)	4
KM-66	Stuffing Box Stud Swivel Washer (Stainless Steel)	4
KP-67V-0805-200	805 Pressure Rings 2	2 sets
KP-67V-0758-200	758 Pressure Rings 2	2 sets
KP-67VPK-0758-200	758/PK Follower Pressure Rings 2	2 sets
KM-67-100	Plunger 1 (Stainless Steel)	2
KM-67-125	Plunger 1 1/4 (Stainless Steel)	2
KM-67-150	Plunger 1 1/2 (Stainless Steel)	2
KM-67-175	Plunger 1 3/4 (Stainless Steel)	2
KM-67-200	Plunger 2 (Stainless Steel)	2
KM-68-625	Plunger 5/8 (Colmonoy 730)	2
KM-68-750	Plunger 3/4 (Colmonoy 730)	2
KM-68-875	Plunger 7/8 (Colmonoy 730)	2
KM-68-100	Plunger 1 (Colmonoy 730)	2
KM-68-125	Plunger 1 1/4 (Colmonoy 730)	2

BUCKHORN
PUMPS, INC.

Kerr KJ-2250/KJ-2250BC Plunger Type Pump

Part Number	Description	# Req
KM-68-150	Plunger 1 1/2 (Colmonoy 730)	2
KM-68-175	Plunger 1 3/4 (Colmonoy 730)	2
KM-68-200	Plunger 2 (Colmonoy 730)	2
KJ-69	Plunger Chamber Cover	2
KJ-69DL	Plunger Chamber Cover for Drip Lube Reservoir	2
AP-72AB	1/8 NPT Oil Level/Stuffing Box Hex Plug (AB)	2
KM-72	Cover Cap Wrench	2
AP-72S	1/8 NPT Oil Level/Stuffing Box Hex Plug (Steel)	3
AP-72SS	1/8 NPT Oil Level/Stuffing Box Hex Plug (Stainless Steel)	3
AP-74	Zert Fitting with Cap	2
KM-75	Bolted Type Stuffing Box Wrench	1
KM-76	Valve Puller Wing Type	1
KM-76M	Valve Puller Wing Guide Pin Type	1
KM-77	Valve Puller Disc Type	1
AP-77T	Valve Insert Tool	1
KM-85AB	Stuffing Box (ALBZ)	2
KM-85S	Stuffing Box (Steel)	2
KM-85SS	Stuffing Box (Stainless Steel)	2
KM-85G	Stuffing Box Gasket	2
KM-87-100AB	Stuffing Box Nut 1 (AB)	2
KM-87-125AB	Stuffing Box Nut 1 1/4 (AB)	2
KM-87-150AB	Stuffing Box Nut 1 1/2 (AB)	2
KM-87-175AB	Stuffing Box Nut 1 3/4 (AB)	2
KM-87-100CS	Stuffing Box Nut (Cast Steel) 1	2
KM-87-125CS	Stuffing Box Nut (Cast Steel) 1 1/4	2
KM-87-150CS	Stuffing Box Nut (Cast Steel) 1 1/2	2
KM-87-175CS	Stuffing Box Nut (Cast Steel) 1 3/4	2
KM-87-100SS	Stuffing Box Nut (Stainless Steel) 1	2
KM-87-125SS	Stuffing Box Nut (Stainless Steel) 1 1/4	2
KM-87-150SS	Stuffing Box Nut (Stainless Steel) 1 1/2	2
KM-87-175SS	Stuffing Box Nut (Stainless Steel) 1 3/4	2
KM-88-100	838 Plunger Packing (Non Adjustable) 1	2 sets
KM-88-125	838 Plunger Packing (Non Adjustable) 1 1/4	2 sets
KM-88-150	838 Plunger Packing (Non Adjustable) 1 1/2	2 sets
KM-88-175	838 Plunger Packing (Non Adjustable) 1 3/4	2 sets

Kerr KJ-2250/KJ-2250BC Plunger Type Pump

Part Number	Description	# Req
KM-88G-100	858 Plunger Packing (Non Adjustable) 1	2 sets
KM-88G-125	858 Plunger Packing (Non Adjustable) 1 1/4	2 sets
KM-88G-150	858 Plunger Packing (Non Adjustable) 1 1/2	2 sets
KM-88G-175	858 Plunger Packing (Non Adjustable) 1 3/4	2 sets
KM-88K-100	Kevlar Packing 1	2 sets
KM-88K-125	Kevlar Packing 1 1/4	2 sets
KM-88K-150	Kevlar Packing 1 1/2	2 sets
KM-88K-150	Kevlar Packing 1 1/2	2 sets
KM-88PK-150	Peak Packing 1 1/2	2 sets
KM-88T-100	Teflon Packing 1	2 sets
KM-88T-125	Teflon Packing 1 1/4	2 sets
KM-88T-150	Teflon Packing 1 1/2	2 sets
KM-88T-175	Teflon Packing 1 3/4	2 sets
KM-88V-0805-125	805 Pressure Rings 1 1/4	2 sets
KM-88V-0805-150	805 Pressure Rings 1 1/2	2 sets
KM-88V-0805-175	805 Pressure Rings 1 3/4	2 sets
KM-88V-0758-125	758 Pressure Rings 1 1/4	2 sets
KM-88V-0758-150	758 Pressure Rings 1 1/2	2 sets
KM-88V-0758-175	758 Pressure Rings 1 3/4	2 sets
KM-88VPK-0758-125	758/PK Follower Pressure Rings 1 1/4	2 sets
KM-88VPK-0758-150	758/PK Follower Pressure Rings 1 1/2	2 sets
KM-88VPK-0758-175	758/PK Follower Pressure Rings 1 3/4	2 sets
KM-89-100AB	Packing Ring 1 (ALBZ)	2
KM-89-125AB	Packing Ring 1 1/4 (ALBZ)	2
KM-89-150AB	Packing Ring 1 1/2 (ALBZ)	2
KM-89-175AB	Packing Ring 1 3/4 (ALBZ)	2
KM-89-100S	Packing Ring 1 (Steel)	2
KM-89-125S	Packing Ring 1 1/4 (Steel)	2
KM-89-150S	Packing Ring 1 1/2 (Steel)	2
KM-89-175S	Packing Ring 1 3/4 (Steel)	2
KM-89-100SS	Packing Ring 1 (Stainless Steel)	2
KM-89-125SS	Packing Ring 1 1/4 (Stainless Steel)	2
KM-89-150SS	Packing Ring 1 1/2 (Stainless Steel)	2
KM-89-175SS	Packing Ring 1 3/4 (Stainless Steel)	2
KM-90-100AB	Packing Lantern Ring 1 (AB)	2

BLACKHORN
PUMPS, INC.

Kerr KJ-2250/KJ-2250BC Plunger Type Pump

Part Number	Description	# Req
KM-90-125AB	Packing Lantern Ring 1 1/4 (AB)	2
KM-90-150AB	Packing Lantern Ring 1 1/2 (AB)	2
KM-90-175AB	Packing Lantern Ring 1 3/4 (AB)	2
KM-90-100S	Packing Lantern Ring 1 (Steel)	2
KM-90-125S	Packing Lantern Ring 1 1/4 (Steel)	2
KM-90-150S	Packing Lantern Ring 1 1/2 (Steel)	2
KM-90-175S	Packing Lantern Ring 1 3/4 (Steel)	2
KM-90-100SS	Packing Lantern Ring 1 (Stainless Steel)	2
KM-90-125SS	Packing Lantern Ring 1 1/4 (Stainless Steel)	2
KM-90-150SS	Packing Lantern Ring 1 1/2 (Stainless Steel)	2
KM-90-175SS	Packing Lantern Ring 1 3/4 (Stainless Steel)	2
KM-90K-100AB	Kevlar Packing Lantern Ring 1	2
KM-90K-125AB	Kevlar Packing Lantern Ring 1 1/4	2
KM-90K-150AB	Kevlar Packing Lantern Ring 1 1/2	2
KM-90K-175AB	Kevlar Packing Lantern Ring 1 3/4	2
KM-90K-100S	Kevlar Packing Lantern Ring 1 (Steel)	2
KM-90K-125S	Kevlar Packing Lantern Ring 1 1/4 (Steel)	2
KM-90K-150S	Kevlar Packing Lantern Ring 1 1/2 (Steel)	2
KM-90K-150S	Kevlar Packing Lantern Ring 1 3/4 (Steel)	2
KM-90K-100SS	Kevlar Packing Lantern Ring 1 (Stainless Steel)	2
KM-90K-125SS	Kevlar Packing Lantern Ring 1 1/4 (Stainless Steel)	2
KM-90K-150SS	Kevlar Packing Lantern Ring 1 1/2 (Stainless Steel)	2
KM-90K-175SS	Kevlar Packing Lantern Ring 1 3/4 (Stainless Steel)	2
KM-91	Screwed Type Stuffing Box Wrench	1
KM-93SL-125AB	Spring Loaded Packing Adapters 1 1/4 (ALBZ)	2 sets
KM-93SL-125S	Spring Loaded Packing Adapters 1 1/4(Steel)	2 sets
KM-93SL-125SS	Spring Loaded Packing Adapters 1 1/4 (Stainless Steel)	2 sets
KM-93SL-150AB	Spring Loaded Packing Adapters 1 1/2 (ALBZ)	2 sets
KM-93SL-150S	Spring Loaded Packing Adapters 1 1/2(Steel)	2 sets
KM-93SL-150SS	Spring Loaded Packing Adapters 1 1/2 (Stainless Steel)	2 sets
KM-93SL-175AB	Spring Loaded Packing Adapters 1 3/4 (ALBZ)	2 sets
KM-93SL-175S	Spring Loaded Packing Adapters 1 3/4 (Steel)	2 sets
KM-93SL-175SS	Spring Loaded Packing Adapters 1 3/4 (Stainless Steel)	2 sets
KM-93SL-200AB	Spring Loaded Packing Adapters 2 (ALBZ)	2 sets
KM-93SL-200S	Spring Loaded Packing Adapters 2 (Steel)	2 sets

Kerr KJ-2250/KJ-2250BC Plunger Type Pump

Part Number	Description	# Req
KM-93SL-200SS	Spring Loaded Packing Adapters 2 (Stainless Steel)	2 sets
KM-94SL-125AB	805 Spring Loaded Packing Sets 1 1/4 (ALBZ)	2 sets
KM-94SL-125S	805 Spring Loaded Packing Sets 1 1/4(Steel)	2 sets
KM-94SL-125SS	805 Spring Loaded Packing Sets 1 1/4 (Stainless Steel)	2 sets
KM-94SL-150AB	805 Spring Loaded Packing Sets 1 1/2 (ALBZ)	2 sets
KM-94SL-150S	805 Spring Loaded Packing Sets 1 1/2(Steel)	2 sets
KM-94SL-150SS	805 Spring Loaded Packing Sets 1 1/2 (Stainless Steel)	2 sets
KM-94SL-175AB	805 Spring Loaded Packing Sets 1 3/4 (ALBZ)	2 sets
KM-94SL-175S	805 Spring Loaded Packing Sets 1 3/4 (Steel)	2 sets
KM-94SL-175SS	805 Spring Loaded Packing Sets 1 3/4 (Stainless Steel)	2 sets
KM-94SL-200AB	805 Spring Loaded Packing Sets 2 (ALBZ)	2 sets
KM-94SL-200S	805 Spring Loaded Packing Sets 2 (Steel)	2 sets
KM-94SL-200SS	805 Spring Loaded Packing Sets 2 (Stainless Steel)	2 sets
KM-94SLG-125AB	758 Spring Loaded Packing Sets 1 1/4 (ALBZ)	2 sets
KM-94SLG-125S	758 Spring Loaded Packing Sets 1 1/4(Steel)	2 sets
KM-94SLG-125SS	758 Spring Loaded Packing Sets 1 1/4 (Stainless Steel)	2 sets
KM-94SLG-150AB	758 Spring Loaded Packing Sets 1 1/2 (ALBZ)	2 sets
KM-94SLG-150S	758 Spring Loaded Packing Sets 1 1/2(Steel)	2 sets
KM-94SLG-150SS	758 Spring Loaded Packing Sets 1 1/2 (Stainless Steel)	2 sets
KM-94SLG-175AB	758 Spring Loaded Packing Sets 1 3/4 (ALBZ)	2 sets
KM-94SLG-175S	758 Spring Loaded Packing Sets 1 3/4 (Steel)	2 sets
KM-94SLG-175SS	758 Spring Loaded Packing Sets 1 3/4 (Stainless Steel)	2 sets
KM-94SLG-200AB	758 Spring Loaded Packing Sets 2 (ALBZ)	2 sets
KM-94SLG-200S	758 Spring Loaded Packing Sets 2 (Steel)	2 sets
KM-94SLG-200SS	758 Spring Loaded Packing Sets 2 (Stainless Steel)	2 sets
KM-94SLGPK-125AB	758/PK Spring Loaded Packing Sets 1 1/4 (ALBZ)	2 sets
KM-94SLGPK-125S	758PK Spring Loaded Packing Sets 1 1/4(Steel)	2 sets
KM-94SLGPK-125SS	758/PK Spring Loaded Packing Sets 1 1/4 (Stainless Steel)	2 sets
KM-94SLGPK-150AB	758/PK Spring Loaded Packing Sets 1 1/2 (ALBZ)	2 sets
KM-94SLGPK-150S	758/PK Spring Loaded Packing Sets 1 1/2(Steel)	2 sets
KM-94SLGPK-150SS	758/PK Spring Loaded Packing Sets 1 1/2 (Stainless Steel)	2 sets
KM-94SLGPK-175AB	758/PK Spring Loaded Packing Sets 1 3/4 (ALBZ)	2 sets
KM-94SLGPK-175S	758/PK Spring Loaded Packing Sets 1 3/4 (Steel)	2 sets
KM-94SLGPK-175SS	758/PK Spring Loaded Packing Sets 1 3/4 (Stainless Steel)	2 sets
KM-94SLGPK-200AB	758/PK Spring Loaded Packing Sets 2 (ALBZ)	2 sets

Kerr KJ-2250/KJ-2250BC Plunger Type Pump

Part Number	Description	# Req
KM-94SLGPK-200S	758/PK Spring Loaded Packing Sets 2 (Steel)	2 sets
KM-94SLGPK-200SS	758/PK Spring Loaded Packing Sets 2 (Stainless Steel)	2 sets
KM-95AB	Stuffing Box (Bolted Type) (ALBZ)	2
KM-95S	Stuffing Box (Bolted Type) (Steel)	2
KM-95SL	Spring Loaded Packing Ring Springs (6 per set)	2 sets
KM-95SS	Stuffing Box (Bolted Type) (Stainless Steel)	2
KP-95W-225	Wave Spring 2-1/4 OD	2
KP-95W-250	Wave Spring 2-1/2 OD	2
KM-96HT	Discharge Valve, Heat Treated, A/R with Insert	2
KM-97HT	Suction Valve, Heat Treated, A/R with Insert	2
KM-98HT	Valve Seat, Heat Treated, A/R	4
KMC-100	Plunger 1 (Ceramic)	2
KM-101R	Abrasive Resistant Valve Insert	4
KM-101A	Abrasive Resistant Valve Insert (Aflax)	4
KM-101N	Abrasive Resistant Valve Insert (Nitrile)	4
KM-101V	Abrasive Resistant Valve Insert	4
KM-104-625AB	805 Spring Loaded Packing Set 5/8 (ALBZ)	2 sets
KM-104-750AB	805 Spring Loaded Packing Set 3/4 (ALBZ)	2 sets
KM-104-875AB	805 Spring Loaded Packing Set 7/8 (ALBZ)	2 sets
KM-104-100AB	805 Spring Loaded Packing Set 1 (ALBZ)	2 sets
KM-104-125AB	805 Spring Loaded Packing Set 1 1/4 (ALBZ)	2 sets
KM-104-625S	805 Spring Loaded Packing Set 5/8 (Steel)	2 sets
KM-104-750S	805 Spring Loaded Packing Set 3/4 (Steel)	2 sets
KM-104-875S	805 Spring Loaded Packing Set 7/8 (Steel)	2 sets
KM-104-100S	805 Spring Loaded Packing Set 1 (Steel)	2 sets
KM-104-125S	805 Spring Loaded Packing Set 1 1/4 (Steel)	2 sets
KM-104-625SS	805 Spring Loaded Packing Set 5/8 (Stainless Steel)	2 sets
KM-104-750SS	805 Spring Loaded Packing Set 3/4 (Stainless Steel)	2 sets
KM-104-875SS	805 Spring Loaded Packing Set 7/8 (Stainless Steel)	2 sets
KM-104-100SS	805 Spring Loaded Packing Set 1 (Stainless Steel)	2 sets
KM-104-125SS	805 Spring Loaded Packing Set 1 1/4 (Stainless Steel)	2 sets
KM-104G-625AB	758 Spring Loaded Packing Set 5/8 (ALBZ)	2 sets
KM-104G-750AB	758 Spring Loaded Packing Set 3/4 (ALBZ)	2 sets
KM-104G-875AB	758 Spring Loaded Packing Set 7/8 (ALBZ)	2 sets
KM-104G-100AB	758 Spring Loaded Packing Set 1 (ALBZ)	2 sets

KERR
PUMPS, INC.

Kerr KJ-2250/KJ-2250BC Plunger Type Pump

Part Number	Description	# Req
KM-104G-125AB	758 Spring Loaded Packing Set 1 1/4 (ALBZ)	2 sets
KM-104G-625S	758 Spring Loaded Packing Set 5/8 (Steel)	2 sets
KM-104G-750S	758 Spring Loaded Packing Set 3/4 (Steel)	2 sets
KM-104G-875S	758 Spring Loaded Packing Set 7/8 (Steel)	2 sets
KM-104G-100S	758 Spring Loaded Packing Set 1 (Steel)	2 sets
KM-104G-125S	758 Spring Loaded Packing Set 1 1/4 (Steel)	2 sets
KM-104G-625SS	758 Spring Loaded Packing Set 5/8 (Stainless Steel)	2 sets
KM-104G-750SS	758 Spring Loaded Packing Set 3/4 (Stainless Steel)	2 sets
KM-104G-875SS	758 Spring Loaded Packing Set 7/8 (Stainless Steel)	2 sets
KM-104G-100SS	758 Spring Loaded Packing Set 1 (Stainless Steel)	2 sets
KM-104G-125SS	758 Spring Loaded Packing Set 1 1/4 (Stainless Steel)	2 sets
KM-104GPK-625AB	758/PK Follower Spring Loaded Packing Set Complete 5/8 AB	2 sets
KM-104GPK-750AB	758/PK Follower Spring Loaded Packing Set Complete 3/4 AB	2 sets
KM-104GPK-875AB	758/PK Follower Spring Loaded Packing Set Complete 7/8 AB	2 sets
KM-104GPK-100AB	758/PK Follower Spring Loaded Packing Set Complete 1 AB	2 sets
KM-104GPK-125AB	758/PK Follower Spring Loaded Packing Set Complete 1 1/4 AB	2 sets
KM-104GPK-625S	758/PK Follower Spring Loaded Packing Set Complete 5/8 Steel	2 sets
KM-104GPK-750S	758/PK Follower Spring Loaded Packing Set Complete 3/4 Steel	2 sets
KM-104GPK-875S	758/PK Follower Spring Loaded Packing Set Complete 7/8 Steel	2 sets
KM-104GPK-100S	758/PK Follower Spring Loaded Packing Set Complete 1 Steel	2 sets
KM-104GPK-125S	758/PK Follower Spring Loaded Packing Set Complete 1 1/4 Steel	2 sets
KM-104GPK-625SS	758/PK Follower Spring Loaded Packing Set Complete 5/8 SS	2 sets
KM-104GPK-750SS	758/PK Follower Spring Loaded Packing Set Complete 3/4 SS	2 sets
KM-104GPK-875SS	758/PK Follower Spring Loaded Packing Set Complete 7/8 SS	2 sets
KM-104GPK-100SS	758/PK Follower Spring Loaded Packing Set Complete 1 SS	2 sets
KM-104GPK-125SS	758/PK Follower Spring Loaded Packing Set Complete 1 1/4 SS	2 sets
KM-105AB	Stuffing Box (ALBZ) 1 3/4 ID	2
KM-105AB	Stuffing Box (Steel) 1 3/4 ID	2
KM-105SS	Stuffing Box (Stainless Steel) 1 3/4 ID	2
KM-105-625AB	Stuffing Box (ALBZ) 1 1/8 ID	2
KM-105-625S	Stuffing Box (Steel) 1 1/8 ID	2
KM-105-625SS	Stuffing Box (Stainless Steel) 1 1/8 ID	2
KM-105-750AB	Stuffing Box (ALBZ) 1 1/2 ID	2
KM-105-750S	Stuffing Box (Steel) 1 1/2 ID	2
KM-105-750SS	Stuffing Box (Stainless Steel) 1 1/2 ID	2

Kerr KJ-2250/KJ-2250BC Plunger Type Pump

Part Number	Description	# Req
KM-105-SL-LRAB	Stuffing Box (ALBZ) 1 3/4 ID Spring Loaded Lubricated	2
KM-105-SL-LRS	Stuffing Box (Steel) 1 3/4 ID Spring Loaded Lubricated	2
KM-105-SL-LRSS	Stuffing Box (Stainless Steel) 1 3/4 ID Spring Loaded Lubricated	2
KM-105-750SL-LRAB	Stuffing Box (ALBZ) 1 1/2 ID Spring Loaded Lubricated	2
KM-105-750SL-LRS	Stuffing Box (Steel) 1 1/2 ID Spring Loaded Lubricated	2
KM-105-750SL-LRSS	Stuffing Box (Stainless Steel) 1 1/2 ID Spring Loaded Lubricated	2
KM-107AB	Stuffing Box Nut (ALBZ)	2
KM-107S	Stuffing Box Nut (Steel)	2
KM-107SS	Stuffing Box Nut (Stainless Steel)	2
KM-107-625AB	Stuffing Box Nut 5/8 (ALBZ)	2
KM-107-625S	Stuffing Box Nut 5/8 (Steel)	2
KM-107-625SS	Stuffing Box Nut 5/8 (Stainless Steel)	2
KM-107-750AB	Stuffing Box Nut 3/4 (ALBZ)	2
KM-107-750S	Stuffing Box Nut 3/4 (Steel)	2
KM-107-750SS	Stuffing Box Nut 3/4 (Stainless Steel)	2
KM-108-750AB	Packing Spacer Ring 3/4 (ALBZ)	2
KM-108-875AB	Packing Spacer Ring 7/8 (ALBZ)	2
KM-108-100AB	Packing Spacer Ring 1 (ALBZ)	2
KM-108-125AB	Packing Spacer Ring 1 1/4 (ALBZ)	2
KM-108-750S	Packing Spacer Ring 3/4 (Steel)	2
KM-108-875S	Packing Spacer Ring 7/8 (Steel)	2
KM-108-100S	Packing Spacer Ring 1 (Steel)	2
KM-108-125S	Packing Spacer Ring 1 1/4 (Steel)	2
KM-108-750SS	Packing Spacer Ring 3/4 (Stainless Steel)	2
KM-108-875SS	Packing Spacer Ring 7/8 (Stainless Steel)	2
KM-108-100SS	Packing Spacer Ring 1 (Stainless Steel)	2
KM-108-125SS	Packing Spacer Ring 1 1/4 (Stainless Steel)	2
KM-108SL-625AB	Spring Loaded Packing Adapters 5/8 (ALBZ)	2
KM-108SL-625S	Spring Loaded Packing Adapters 5/8 (Steel)	2
KM-108SL-625SS	Spring Loaded Packing Adapters 5/8 (Stainless Steel)	2
KM-108SL-750AB	Spring Loaded Packing Adapters 3/4 (ALBZ)	2
KM-108SL-750S	Spring Loaded Packing Adapters 3/4 (Steel)	2
KM-108SL-750SS	Spring Loaded Packing Adapters 3/4 (Stainless Steel)	2
KM-108SL-875AB	Spring Loaded Packing Adapters 7/8 (ALBZ)	2
KM-108SL-875S	Spring Loaded Packing Adapters 7/8 (Steel)	2

KERR HORN
PUMPS, INC.

Kerr KJ-2250/KJ-2250BC Plunger Type Pump

Part Number	Description	# Req
KM-108SL-875SS	Spring Loaded Packing Adapters 7/8 (Stainless Steel)	2
KM-108SL-100AB	Spring Loaded Packing Adapters 1 (ALBZ)	2
KM-108SL-100S	Spring Loaded Packing Adapters 1 (Steel)	2
KM-108SL-100SS	Spring Loaded Packing Adapters 1 (Stainless Steel)	2
KM-108SL-125AB	Spring Loaded Packing Adapters 1 1/4 (ALBZ)	2
KM-108SL-125S	Spring Loaded Packing Adapters 1 1/4 (Steel)	2
KM-108SL-125SS	Spring Loaded Packing Adapters 1 1/4 (Stainless Steel)	2
KM-109-875AB	Packing Lantern Ring 7/8 (AB)	2
KM-109-100AB	Packing Lantern Ring 1 (AB)	2
KM-109-125AB	Packing Lantern Ring 1 1/4 (AB)	2
KM-109-875S	Packing Lantern Ring 7/8 (Steel)	2
KM-109-100S	Packing Lantern Ring 1 (Steel)	2
KM-109-125S	Packing Lantern Ring 1 1/4 (Steel)	2
KM-109-875SS	Packing Lantern Ring 7/8 (Stainless Steel)	2
KM-109-100SS	Packing Lantern Ring 1 (Stainless Steel)	2
KM-109-125SS	Packing Lantern Ring 1 1/4 (Stainless Steel)	2
KM-109SL-LR-750AB	Spring Loaded Packing Lantern Ring 3/4 (ALBZ)	2
KM-109SL-LR-750S	Spring Loaded Packing Lantern Ring 3/4 (Steel)	2
KM-109SL-LR-750SS	Spring Loaded Packing Lantern Ring 3/4 (Stainless Steel)	2
KM-109SL-LR-875AB	Spring Loaded Packing Lantern Ring 7/8 (ALBZ)	2
KM-109SL-LR-875S	Spring Loaded Packing Lantern Ring 7/8 (Steel)	2
KM-109SL-LR-875SS	Spring Loaded Packing Lantern Ring 7/8 (Stainless Steel)	2
KM-109SL-LR-100AB	Spring Loaded Packing Lantern Ring 1 (ALBZ)	2
KM-109SL-LR-100S	Spring Loaded Packing Lantern Ring 1 (Steel)	2
KM-109SL-LR-100SS	Spring Loaded Packing Lantern Ring 1 (Stainless Steel)	2
KM-109SL-LR-125AB	Spring Loaded Packing Lantern Ring 1 1/4 (ALBZ)	2
KM-109SL-LR-125S	Spring Loaded Packing Lantern Ring 1 1/4 (Steel)	2
KM-109SL-LR-125SS	Spring Loaded Packing Lantern Ring 1 1/4 (Stainless Steel)	2
KM-110-875AB	Packing Ring 7/8 (AB)	2
KM-110-100AB	Packing Ring 1 (AB)	2
KM-110-125AB	Packing Ring 1 1/4 (AB)	2
KM-110-875S	Packing Ring 7/8 (Steel)	2
KM-110-100S	Packing Ring 1 (Steel)	2
KM-110-125S	Packing Ring 1 1/4 (Steel)	2
KM-110-875SS	Packing Ring 7/8 (Stainless Steel)	2

BUCKHORN
PUMPS, INC.

Kerr KJ-2250/KJ-2250BC Plunger Type Pump

Part Number	Description	# Req
KM-110-100SS	Packing Ring 1 (Stainless Steel)	2
KM-110-125SS	Packing Ring 1 1/4 (Stainless Steel)	2
KM-111-875	838 Plunger Packing 7/8	2 sets
KM-111-100	838 Packing 1	2 sets
KM-111-125	838 Plunger Packing 1 1/4	2 sets
KM-111G-875	858 Plunger Packing 7/8	2 sets
KM-111G-100	858 Plunger Packing 1	2 sets
KM-111G-125	858 Plunger Packing 1 1/4	2 sets
KM-111T-875	Teflon Plunger Packing 7/8	2 sets
KM-111T-100	Teflon Packing 1	2 sets
KM-111T-125	Teflon Plunger Packing 1 1/4	2 sets
KM-111K-875	Kevlar Plunger Packing 7/8	2 sets
KM-111K-100	Kevlar Packing 1	2 sets
KM-111K-125	Kevlar Plunger Packing 1 1/4	2 sets
KM-112	Pony Rod Splash Guard	1
KJ-113	Complete Gasket Kit -- Contents: (1) KM-3, (2) KM-7, (1) KJ-12, (1) KJ-15, (2 SETS) KM-29, (2) KM-30, (2) KM-33, (6) KM-37, (2) KM-85G, (2) KM-112	
KJ-114	Lubrication System Complete	1
AP-115	Check Valve Stainless Steel 1/8 Pipe	2
KJ-115	Lubrication System Less Lubricator	1
AP-116	55 Single Pump for Forced Feed Lubricator	2
KM-117	Crankshaft Lubrication Sheave	1
AP-117L-6	Lubricator Driven Sheave	1
KM-118	Lubrication Belt	1
KJ-119	Lubricator Bracket	1
KMC-125	Plunger 1 1/4 (Ceramic)	2
KMC-150	Plunger 1 1/2 (Ceramic)	2
KMC-175	Plunger 1 3/4 (Ceramic)	2
KMC-200	Plunger 2 (Ceramic)	2
KM-276	Installation Tool for Pony Rod Seal	
KM-277	Pony Rod Installation Wrench	1
KM-300AB	Discharge Valve Assy (ALBZ) (KM-39, KM-41 & KM- 58L)	2
KM-300HT	Abrasive Resistant Discharge Valve Complete (KM-96HT, KM-98HT & KM-58L)	2
KM-300M	Monel Discharge Valve Complete (KM-42, KM-44, KM-58L)	2
KM-300SS	Stainless Steel Discharge Valve Assy (KM-55, KM-57 & KM-58L)	2

Kerr KJ-2250/KJ-2250BC Plunger Type Pump

Part Number	Description	# Req
KM-305AB	Suction Valve Assy (ALBZ) (KM-40, KM-41, & KM-58S)	2
KM-305HT	Abrasive Resistant Suction Valve Complete (KM-97HT, KM-98HT & KM-58S)	2
KM-305SS	Stainless Steel Suction Valve Complete (KM-56, KM-57 & KM-58S)	2
KM-305M	Suction Valve Assembly Monel	2
AP-351	Oil Level Sight Glass	1
AP-352	Oil Level Sight Plug	1
AP-425	Wrench, Stuffing Box Nut	1
KMC-750	Plunger 3/4 (Ceramic)	2
KM-800-750	Kerramic Plunger 3/4	1
KM-800-875	Kerramic Plunger 7/8	1
KM-800-100	Kerramic Plunger 1	1
KM-800-125	Kerramic Plunger 1 1/4	1
KM-800-150	Plunger Kerramic 1 1/2	1
KM-800-175	Plunger Kerramic 1 3/4	1
KM-800-200	Plunger Kerramic 2	1
KMC-875	Plunger 7/8 (Ceramic)	2

All prices and part numbers are subject to change without prior notice.

BUCKHORN
PUMPS, INC.

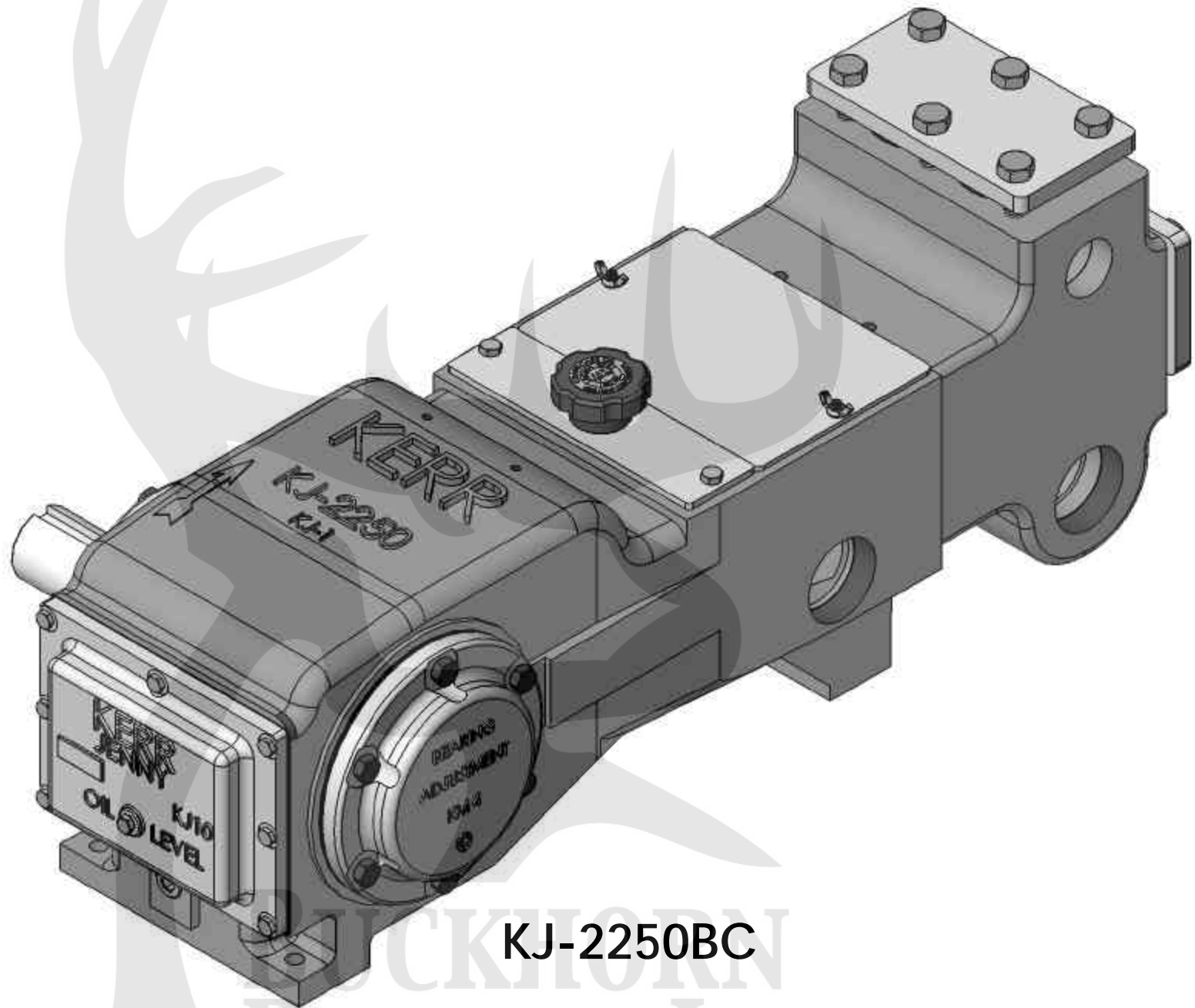

KJ-2250BC

BUCKHORN
PUMPS, INC.

KJ-2250BC PLUNGER TYPE PUMP TORQUE SPECIFICATIONS

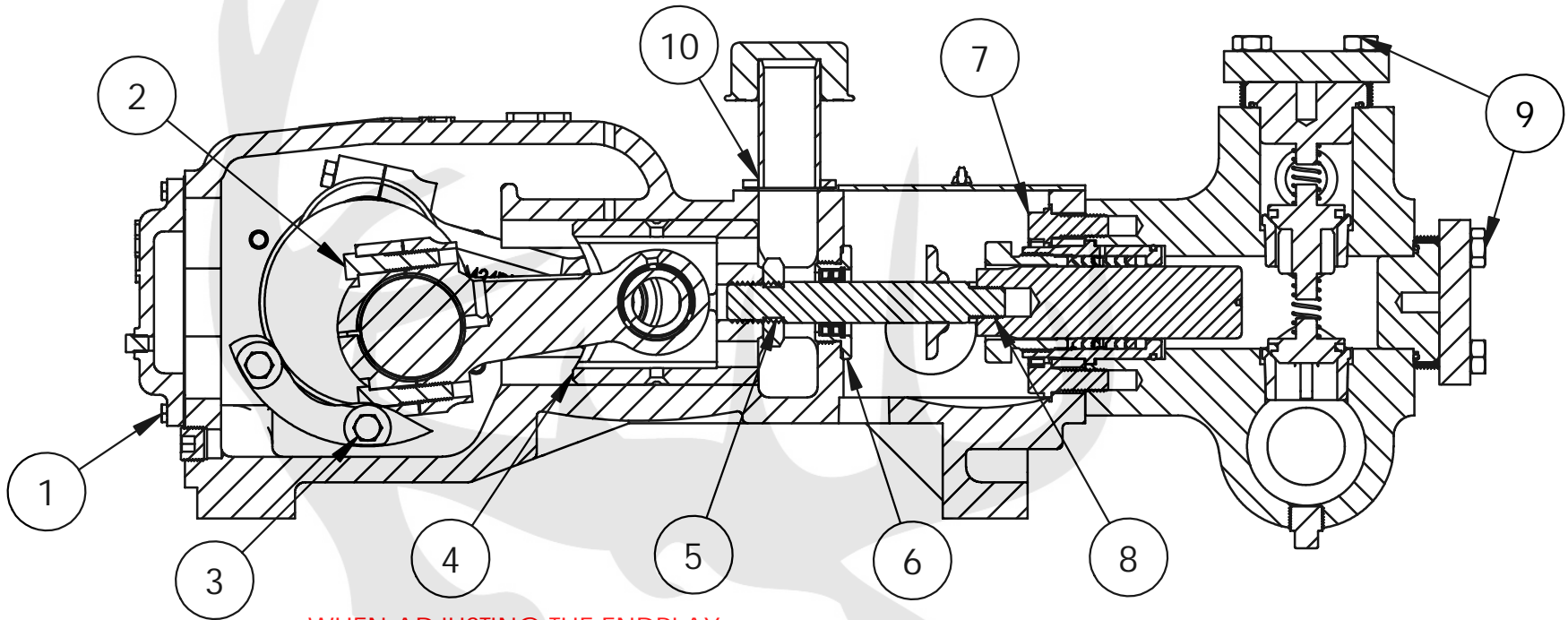

WHEN ADJUSTING THE ENDPLAY OF THE TAPERED ROLLER BEARINGS USED ON THE CRANKSHAFT, DIAL INDICATORS AND SHIMS MUST BE PROPERLY USED. INCORRECT BEARING ADJUSTMENT MAY RESULT IN EXCESSIVE NOISE, TEMPERATURE, AND REDUCED BEARING LIFE. Kerr Pumps RECOMMENDS BETWEEN .000" - .005" OF INTERNAL AXIAL CLEARANCE (END PLAY OR SIDE TO SIDE) WHEN ASSEMBLED. FINAL ADJUSTMENT MUST BE MADE USING A DIAL INDICATOR.

INSURE THE CONNECTING RODS ARE DISCONNECTED TO ALLOW FREE CRANKSHAFT MOTION.

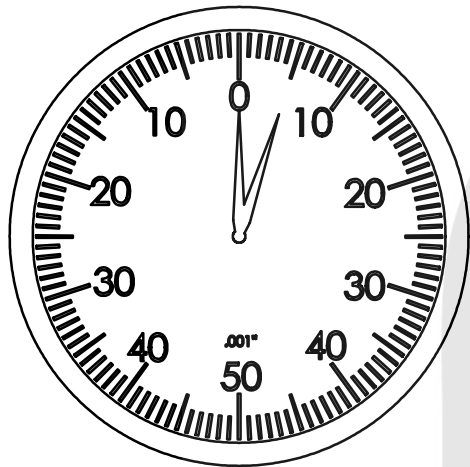

- .000"-.005" SHAFT END PLAY
- .003"-.004" CONNECTING ROD AT CRANKSHAFT
- .001" .002" CONNECTING ROD AT WRIST PIN

TORQUE SPECIFICATIONS

REFERENCE	DESCRIPTION	TORQUE
1	PAN COVER CAPSCREW	9 ft-lb (12 Nm)
2	CONNECTING ROD CAPSCREW	65 ft-lb (88 Nm)
3	BEARING HOUSING CAPSCREW	50 ft-lb (68 Nm)
4	WRIST PIN SET SCREW AND JAM NUT	12 ft-lb (16 Nm)
5	PONY ROD	500 ft-lb (678 Nm)
6	PONY ROD PACKING GLAND	50 ft-lb (68 Nm)
7	FLUID END CAP SCREW	175 ft-lb (237 Nm)
8	PLUNGER TO PONY ROD	300 ft-lb (407 Nm)
9	FLUID END COVER PLATE CAPSCREWS	175 ft-lb (237 Nm)
10	CROSSHEAD COVER PLATE CAPSCREW	10 ft-lb (14 Nm)

NOTE: WHEN USING LUBRICANTS, REDUCE TORQUE AS FOLLOWS;

LUBRICANT	PERCENTAGE OF TORQUE REDUCTION REQUIRED
OIL & GREASE	REDUCE TORQUE 40%
ANTI - SEIZE COMPOUND	REDUCE TORQUE 45%

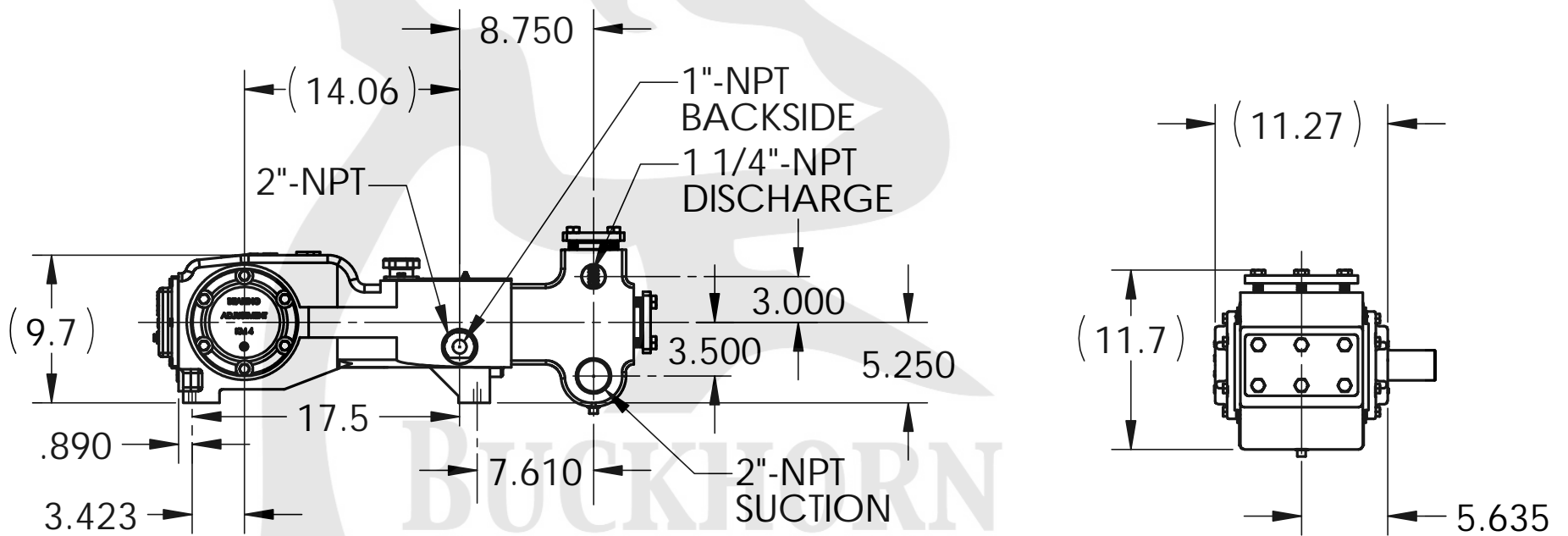
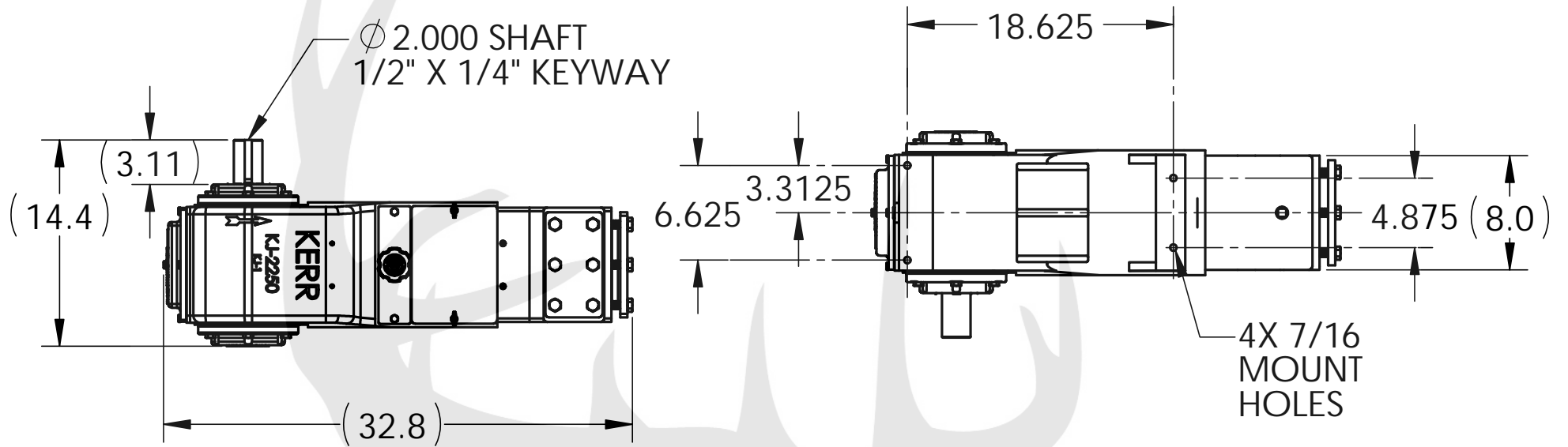

GENERAL DIMENSIONS FOR KJ-2250BC

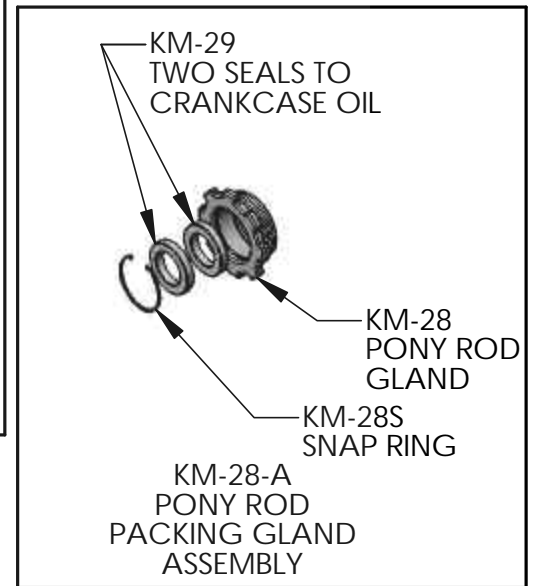
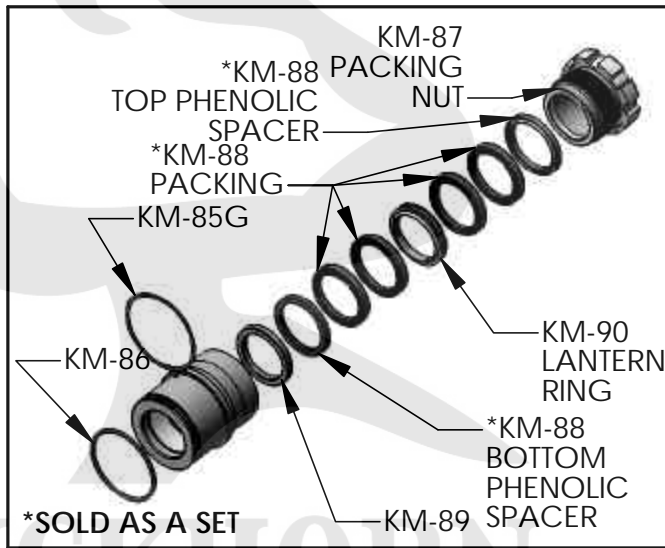
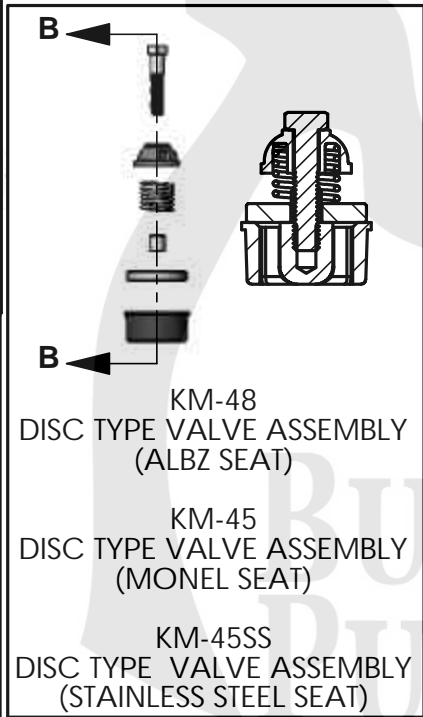
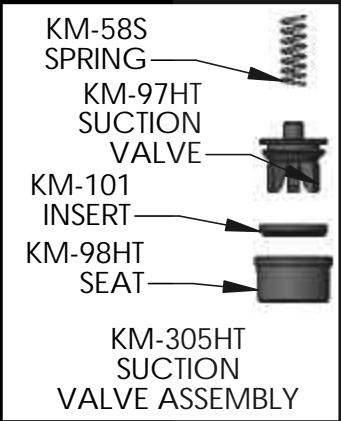
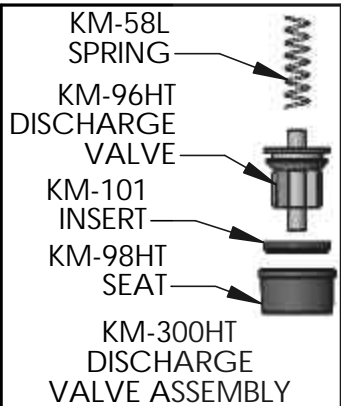
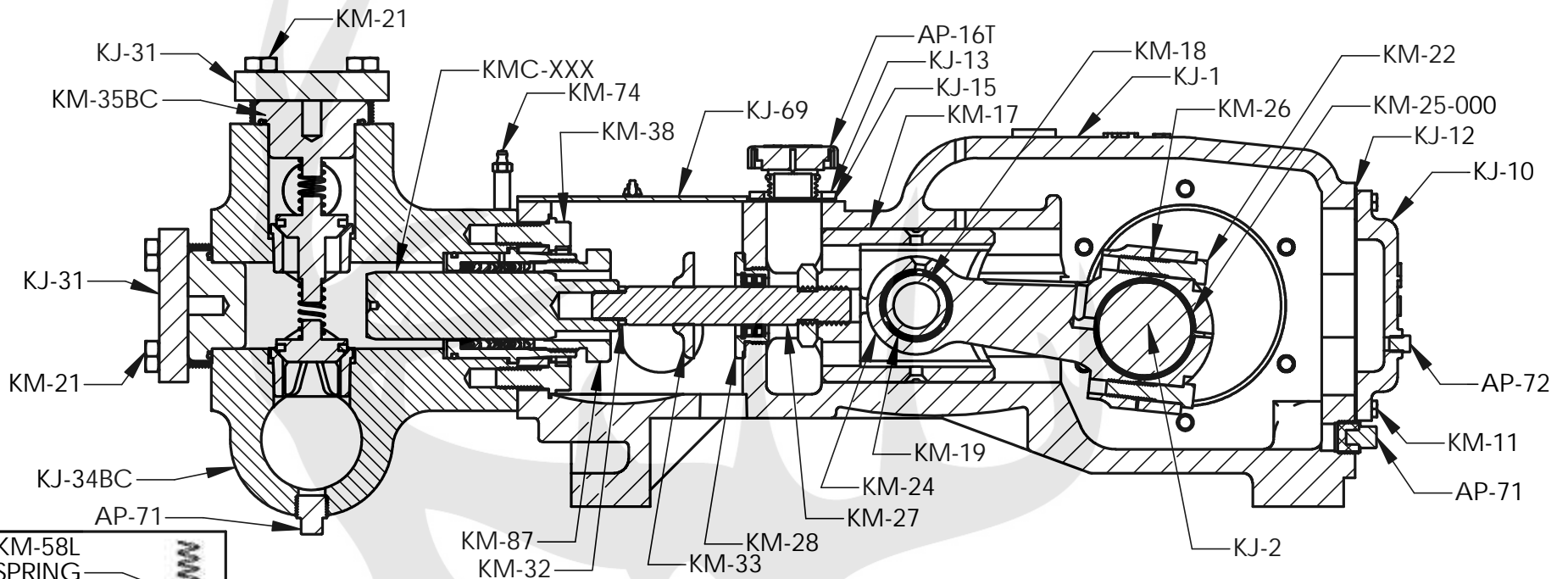

KJ-2250BC

BUCKHORN PUMPS, INC.