

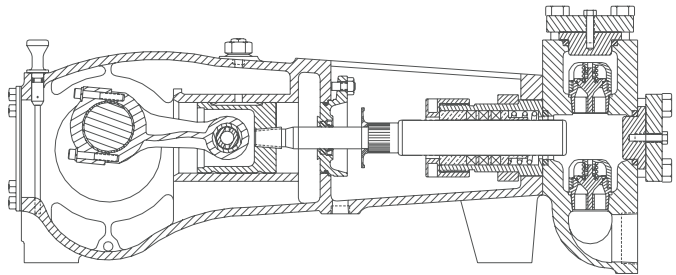

MYERS® APLEX SERIES

SC-80

QUINTUPLEX PLUNGER PUMP



Intermittent Duty Only

No. of plungers	5
Maximum rated speed	600rpm
Stroke length.....	2.25 in. 57.15 mm
Maximum rated power.....	100 HP 74.5 KW
Maximum rod load	5280 lb. 23.44 kN
Weight	510 lbs.

ENGLISH UNITS

SC-80

PLUNGER SIZE IN.	STUFFING BOX BORE IN.	MAX PSI.	* GALLON PER/REV.	200 RPM US GPM	300 RPM US GPM	400 RPM US GPM	500 RPM US GPM	600 RPM US GPM
1.875	2.500	1912	0.1345	26.9	40.3	53.8	67.2	80.7
1.750	2.500	2195	0.1171	23.4	35.1	46.9	58.6	70.3
1.625	2.500	2550	0.1010	20.2	30.3	40.4	50.5	60.6
1.500	2.500	3000	0.0861	17.2	25.8	34.4	43.0	51.6
1.375	2.250	3500	0.0723	14.5	21.7	28.9	36.2	43.4
HP REQUIRED @ RPM**				33.4	50.1	66.7	83.4	100.0

METRIC UNITS

SC-80

PLUNGER SIZE MM.	STUFFING BOX BORE MM.	MAX PRESS. BAR	* LITER PER/REV.	200 RPM LPM	300 RPM LPM	400 RPM LPM	500 RPM LPM	600 RPM LPM
47.6	63.5	131.8	0.5091	101.8	152.7	203.6	254.6	305.5
44.5	63.5	151.3	0.4433	88.7	133.0	177.3	221.7	266.0
41.3	63.5	175.8	0.3824	76.5	114.7	153.0	191.2	229.4
38.1	63.5	206.0	0.3259	65.2	97.8	130.4	163.0	195.5
34.9	57.1	241.4	0.2736	54.7	82.1	109.4	136.8	164.2
KW REQUIRED @ RPM**				24.9	37.4	49.7	62.2	74.6

*Displacement based on 100% Volumetric Efficiency

**Power based on 90% Mechanical Efficiency

$$IHP = \frac{USGPM \times (\text{Discharge psig} - 1/2 \text{ Suction psig})}{1542}$$

$$IKW = \frac{M^3/HR \times (\text{Discharge Bar} - 1/2 \text{ Suction Bar})}{17.99}$$

$$PUMP \text{ RPM} = \frac{USGPM \text{ Desired}}{USGPM \text{ per Revolution of Selected Plunger}}$$

$$PUMP \text{ RPM} = \frac{M^3/HR \text{ Desired}}{M^3 \text{ per Revolution of Selected Plunger}}$$

SC-80 Quintuplex Pump

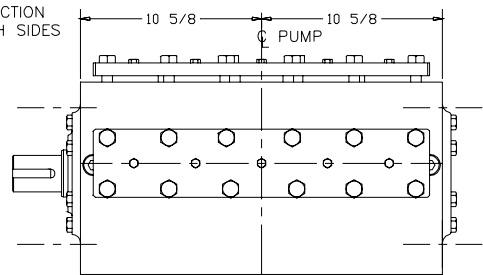
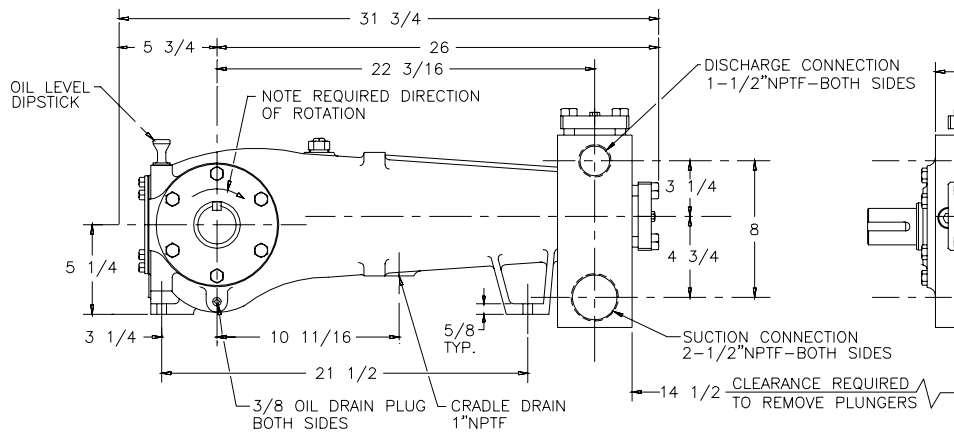
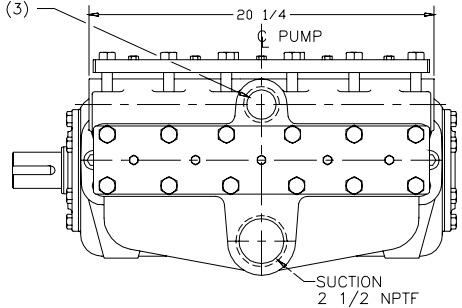
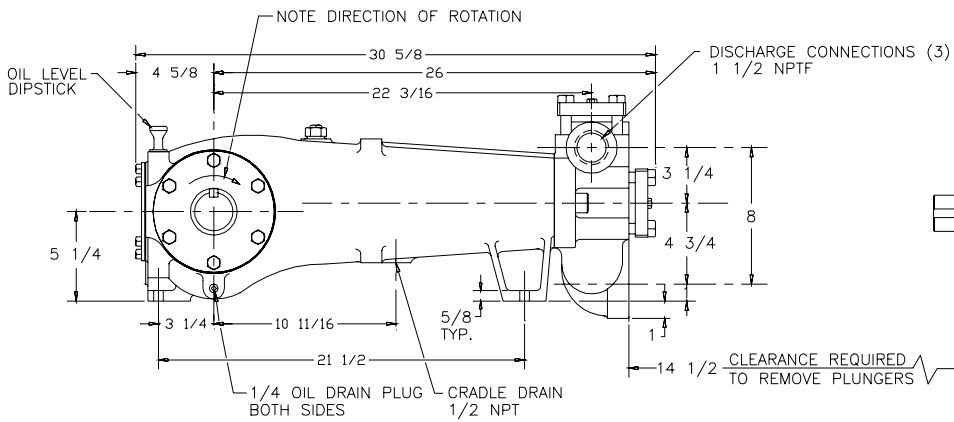
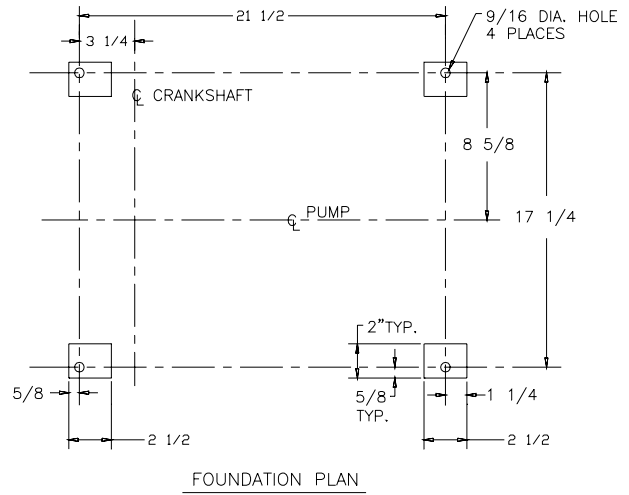
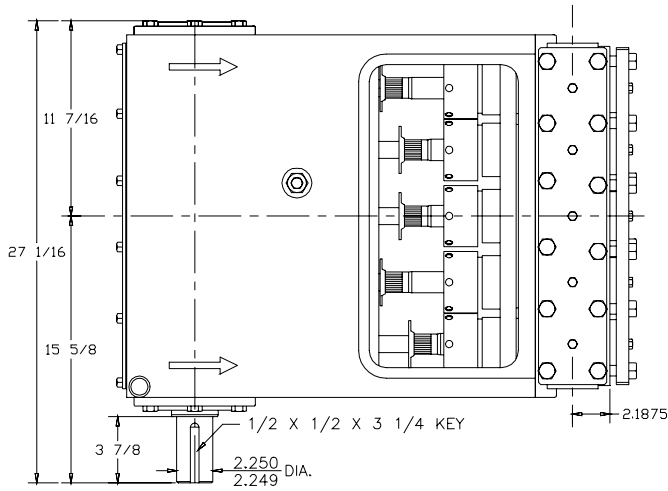

ENGINEERING DATA

SC-80 Quintuplex Pump

POWER END ENGINEERING DATA

Max. Input Power @ Speed	100 HP @ 600 rpm
Rated Continuous Plunger Load	5,280 lb.
Normal Continuous Speed Range	600 rpm
Minimum Speed	50 rpm
Oil Capacity	8 U.S. Qrts
Power End Oiling System	Splash & Scoop
Power Frame, One-Piece	Cast Iron
Crosshead, Full Cylindrical	Cast Iron
Crosshead, Dia. x Length.....	3 1/4 x 3 5/8 in.
Crankshaft	Ductile Iron
Crankshaft Diameters:	
At Tapered Roller Bearings	3.15 in.
At Crankpin Bearings, Dia. x Length	2 1/4 x 1 5/8 in.
Crosshead (Wrist) Pin, Case-Hardened and Ground	AISI 8620
Main Bearings, Tapered Roller	Timken®
Crankpin Bearings, Precision Automotive	Babbitt-Lined
Extension (Pony) Rod Integral w/ Plungers	316 S.ST.
Connecting Rod, Automotive Type	Ductile Iron
Average Crosshead Speed @ 550 rpm	225 fpm
Minimum Life Expectancy, Main Bearings, L ₁₀	30,000+ hr.

LIQUID END ENGINEERING DATA

Max. Continuous Working Pressure	3,500 psi
Hydrostatic Test	5,250 psi
Liquid End Materials, A.S.T.M.	
Ductile Iron.....	A536 80-55-06
Carbon Steel.....	A516 Gr.70
Stainless Steel.....	316 or 2205 S.ST.
Plunger Type Rokide® Stainless Steel, (Chromium Oxide-Coated)	316 S.ST.
Stuffing boxes, Field-Removable and Replaceable, Carbon Steel	1020
Packing Types Available:	
Gland-loaded, Non-Adjustable	Style 838
Spring-loaded, Braided Teflon® & Kevlar®	Style 140
Spring-loaded, cup-type	Style 120X
Spring-loaded, Garlock	Style 892LK
Valve Cover and Cyl. Head Plugs	316 S.ST.
Retainer Plates, Steel, A.S.T.M.	A36
Seals, Stuffing Boxes, Valve Covers	Buna-N
Valve Type, Double Stem-Guided	17-4PH S.ST.
Valve Spring Material	Inconel®
Valve Seat, Liquid Passage Area.....	1.400 sq.in.
Avg. Liquid Velocity, with 1 7/8" Plungers @ 550 RPM	
thru Plate Valves	7.40 fps
thru Dual Stem Valves.....	10.81 fps
thru Suction Manifold.....	5.40 fps
thru Discharge Manifold	14.65 fps

All drawings and specifications subject to change without notice.

SC-80 Quintuplex Pump

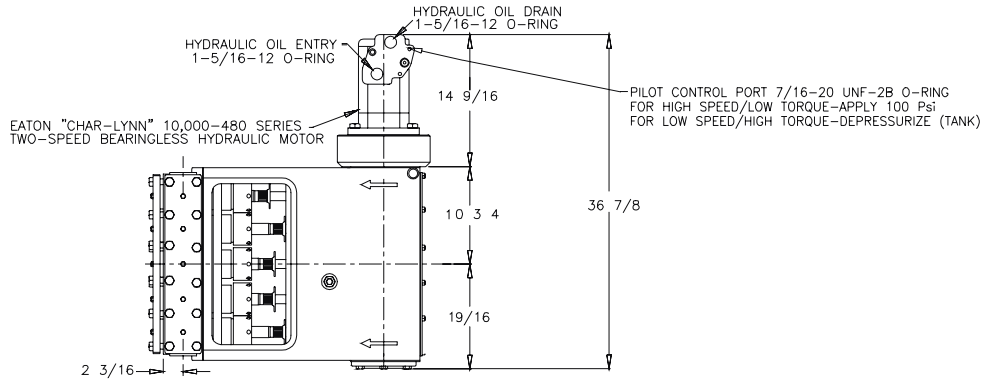
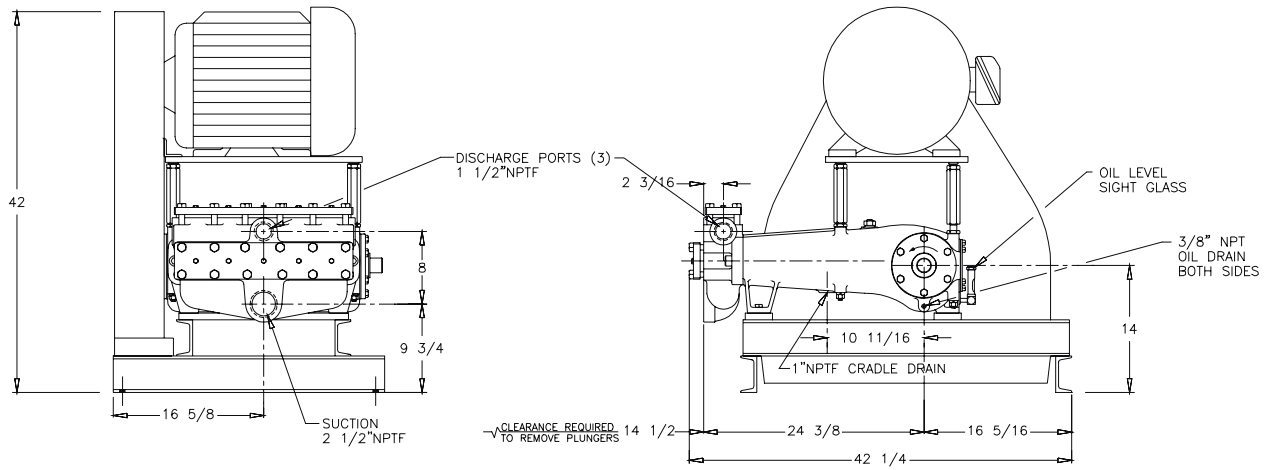

740 EAST 9TH STREET,
ASHLAND, OHIO 44805
WWW.FEMYERS.COM

490 PINEBUSH ROAD, UNIT 4,
CAMBRIDGE, ONTARIO N1T 0A5
WWW.FEMYERS.COM

Teflon® and Kevlar® are registered trademarks of E. I. du Pont de Nemours and Company. Inconel® is a registered trademark of the Special Metals family of companies. Timken® is a registered trademark of The Timken Company. Rokide® is a registered trademark of Saint-Gobain Abrasives, Inc. Myers® is a registered trademark of Pentair.

Because we are continuously improving our products and services, Pentair reserves the right to change specifications without prior notice.
MA3008 12/27/13 © 2013 Pentair Ltd. All Rights Reserved.